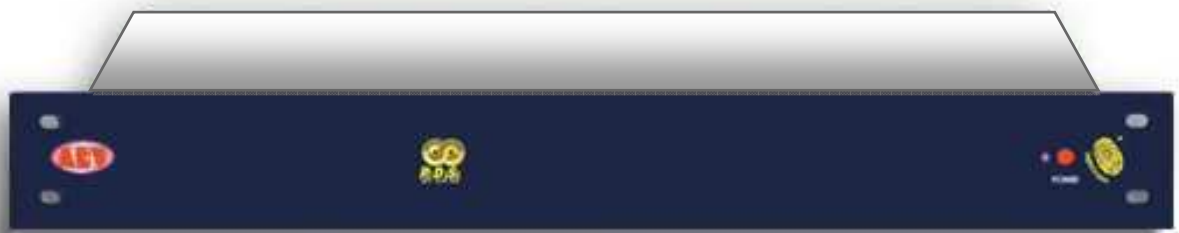




# **AEV RDS 4500**

## **Radio Data System**



### **Guarantee**

The equipment is warranted for a period of 2 years from the date of invoice (ex-works). The warranty does not cover faults provoked by carelessness, natural causes and parts subject to wear. In addition, the cost of labour and shipment is not covered. The warranty will be voided if the equipment is mishandled.

### **Technical Support**

If you require technical support, contact AEV SERVICE giving a clear and concise account of your specific problem. Quote the serial number of your equipment by referring to the AEV nameplate attached to the equipment itself as this is the most important piece of information to be provided.

Telephone: +39 051892963 Fax: +39 051893605

### **Factory Service and Repairs**

If problems arise while the equipment is being installed, consult this manual and check that the installation is being carried out properly. If the problems still cannot be solved, call the AEV SERVICE Department for further information. If the problem is a minor one we can a telephone call will probably suffice. If, on the other hand, the equipment is to be shipped to AEV for service or repairs, the AEV SERVICE Dept. will accept it only if the RMA return authorisation number has been provided. This number must be included in the shipping documents. We also recommend providing a detailed description of the fault which has occurred, the type of service needed and (if required) the name of the employee at the AEV SERVICE Dept. you have spoken to. No repairs will be made if the cost of shipment is charged to AEV. In this case, we will not accept the delivery.

### **Shipping Instruction**

When shipping the equipment to AEV, use the original package in order to be certain that it will be fully protected during handling. If you need the original package, call us for a new one. If you ship the equipment in a different packing container, take care to provide a double package by interposing padding material between the two containers in order to fully protect the equipment during shipment. The package should be marked "FRAGILE" in red. Remember that the RMA number must be clearly visible on the package. If it is not, the equipment will not be accepted.

## **SAFETY PRECAUTIONS**

**IMPORTANT:** Carefully read this paragraph as it contains important instructions concerning operator safety and directions regarding the installation, operation and maintenance of the equipment.

Failure to observe the safety instructions and information given in this manual **constitutes an infringement of the safety rules and design specifications provided for this piece of equipment.**

**Futurcom srl declines all responsibility** if any one of the safety rules given herein is not observed.

**Futurcom srl declines all responsibility** if the end-user resells the product.

The equipment is to be used by people capable of operating it in a trouble-free manner and **it is assumed that they are aware of the following safety rules.**

- Keep this manual with the utmost care and close at hand so that it can be consulted whenever needed.
- After unpacking the equipment, check it for condition.
- Avoid banging the equipment.
- The packing material (plastic bags, polystyrene, nails, etc.) must never be left within the reach of the children, as **these items are potential sources of danger.**
- Do not use the equipment in places where the temperature is not within the recommended range, as specified by the manufacturer.
- Before connecting the equipment, make sure the nameplate specifications correspond to the mains electricity supply (the nameplate is located on the equipment enclosure).

- Do not remove the sticker from the equipment as it contains important specifications and the relevant serial number.
- To join the equipment to the mains supply, use the power cord purchased with the equipment.
- The equipment must be used only for the purpose it was designed for.
- Abuse or misuse of the equipment is **extremely dangerous** for people, pets and property. The manufacturer declines all responsibility for damage and injury resulting from **improper use** and **mishandling**.
- Certain basic safety rules must be observed when using electrical equipment, in particular:
  - Never touch the equipment with wet and/or damp hands or other parts of the body.
  - Keep the equipment away from drops of water or sprinkling systems.
  - Never use the equipment near high heat sources or explosive material.
  - Do not introduce any extraneous matter into the equipment.
  - Do not allow children or untrained people to use the equipment.
- Before cleaning or servicing the equipment outside, disconnect it from the supply and wait at least 2 seconds before working on it, as recommended by current safety regulations.
- In the event of faults and/or improper operation, turn off the equipment, shut off the electrical power and call your dealer.
- Do not attempt to make repairs and/or adjustments when covers/ guards or circuit boards are to be removed.
- Blown fuses inside the power supply indicate that there may be a fault in the power supply itself. The fuses must be replaced by qualified and authorised persons. It is advisable to call your nearest dealer.
- Call your dealer for any repairs and be certain original spare parts are used. **Failure to observe this rule may adversely affect the safety level of your equipment.**
- The equipment is to be connected to the mains supply and provided with adequate and efficient earth conductors.
- The electrical wiring must be done in compliance with current electrical codes CEI 64-8 "Electrical specification for domestic buildings".
- When installing, leave a clearance of at least 1 cm around the equipment to allow air to pass freely.

**NOTE. This piece of equipment has been manufactured to the highest standards of workmanship. It must be used properly and serviced as recommended to ensure long-term dependable operation.**

**RDS 4500** is an equipment that should be installed in a rack. The installation must be done in order to be able to guarantee an easy access to the cable of feeding. The device of dissection of the equipment is the cable of feeding, so it must be unconnected from the equipment every time it is necessary to do any type of maintenance.

## Contents

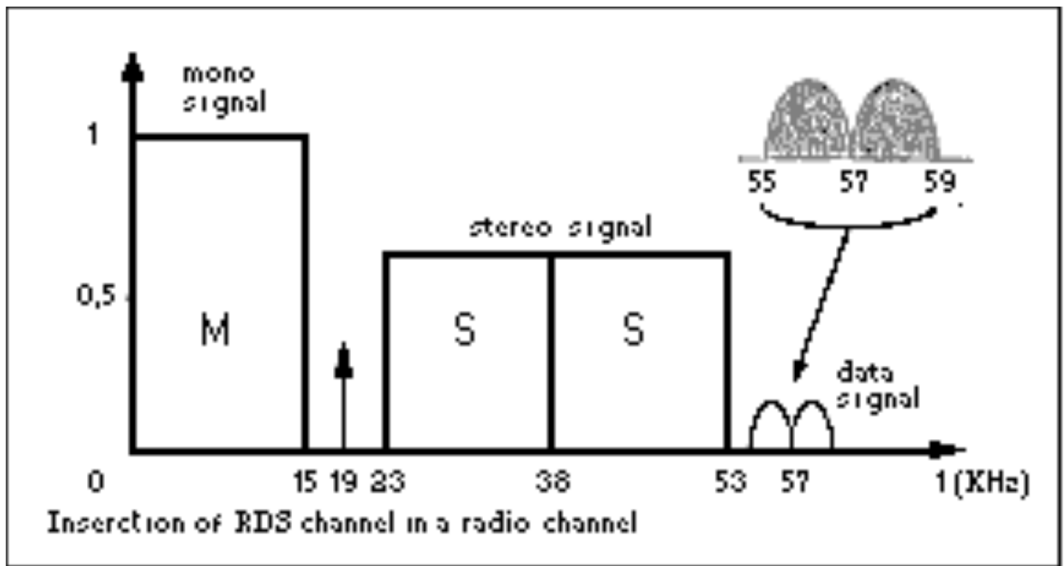
Guarantee .....	2
Technical Support .....	2
Factory Service and Repairs .....	2
Shipping Instruction .....	2
SAFETY PRECAUTIONS.....	2
Contents.....	4
- RDS - radiodata .....	5
Applications .....	8
General Description .....	8
Definition of terms.....	8
Program Identifier (PI) .....	8
Program Service name (PSN) .....	8
Traffic Program identifier (TP) .....	8
Alternative Frequency list (AF) .....	8
Traffic Announcement identifier (TA) .....	8
Program Type (PTY) .....	8
Decoder Identifier (DI) .....	9
Music / Speech (M/S) .....	9
Program Identification Number (PIN) .....	9
Radiotext (RT) .....	9
Other Network information (EON) .....	9
Transparent Data Channel (TDC) .....	9
Clock Time (CT).....	9
Fast basic tuning and switching information .....	10
Traffic Message Channel .....	10
Enhanced Other Network (EON) .....	10
Linkage Information (LI) .....	10
Language Identification Code (LIC) .....	10
Extended Country Code (ECC) .....	10
Panels .....	10
Front panel .....	10
Rear panel .....	10
Description of rear panel controls .....	10
Installation .....	10
Interconnection .....	11
RS232 Serial Port .....	11
PC software.....	11
Electrical Specifications .....	27
RDS Generator .....	27
Data Synchronization.....	27
Remote I/O .....	27
General Data .....	27
Connection PC - RS232.....	28
Sample connection Remote .....	29
Jumper & Dip Setting .....	29
Preset dip .....	29

**AEV AEV RDS 4500 – rds encoder**  
**- RDS - radiodata**

This system for the transmission of additional information on mono and stereo VHF (87.5-107.5MHz), represents the most technically advanced and, for the huge range of possible applications, the only that has any real chance of being adopted on a global basis. It fulfils the various requirements needed by systems for the transmission of additional data on radio programs, namely:

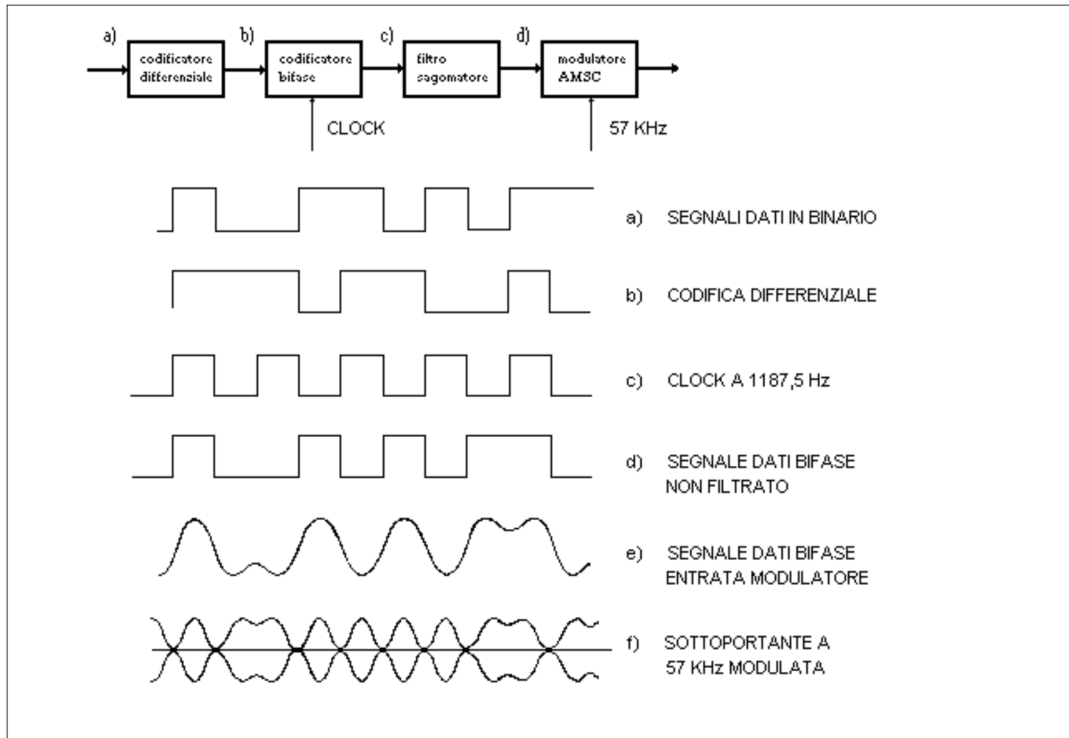
- COMPATIBILITY WITH THE MAIN PROGRAM, MONO AND STEREO;
- ABSENCE OF INTERFERENCE ON ADJACENT FM CHANNELS;
- POTENTIALLY BETTER COVERAGE AREA COMPARED TO MONO TRANSMISSIONS
- COMPATIBLE WITH OTHER IDENTIFICATION SYSTEMS, ALREADY IN SERVICE.

Radiodata is the fruit of work undertaken by a specialized UER group, based on five proposals formulated by Sweden, The Netherlands, Great Britain, Finland and France. The superiority of this system results mainly from its protection from transmission errors, crucial for in-car reception, high speed to synchronize the data groups, from its high data rate, its potential for new applications and flexibility of use. The spectrum of a multiplex, stereophonic signal, containing data is shown in fig.1.



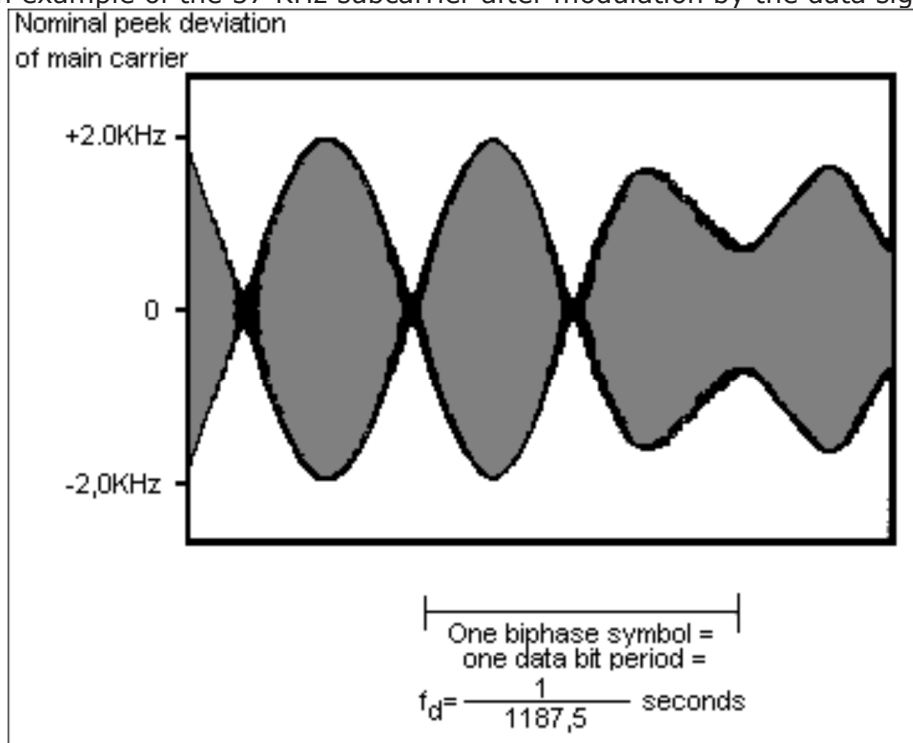
**Figure 1**

The signal is transmitted by amplitude modulating, in suppressed carrier mode, a 57 KHz (3 times the 19 KHz pilot) subcarrier with a deviation of  $\pm 2$  KHz of the RF carrier, retaining a maximum deviation of  $\pm 75$  KHz for the multiplex, composite audio/data signal. Data transmission speed is 1187.5 bit/s and, being biphase coded, produces a spectrum of about  $\pm 2$  KHz around the 57 KHz frequency which is suppressed-carrier modulated. Carrier suppression is required to enable co-existence with ARI signals, since the latter transmits information using narrow-band (about 250 Hz) DSB amplitude modulation. The most important waveforms produced by this modulation are shown in fig.2 below.



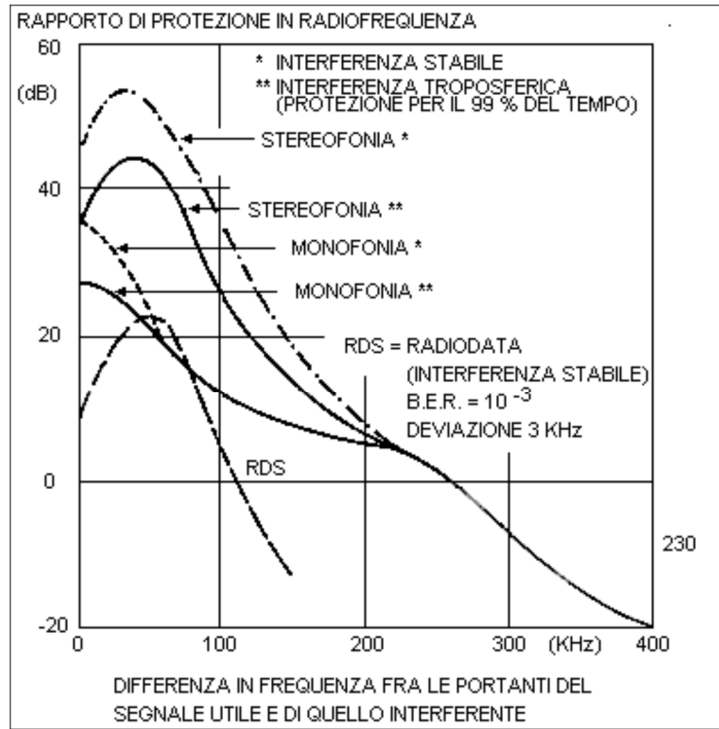
To avoid phase ambiguity on recovering the 57 KHz subcarrier, in the case of coherent demodulation, the binary data signal undergoes differential encoding prior to biphase encoding.

Fig.3 gives an example of the 57 KHz subcarrier after modulation by the data signal.

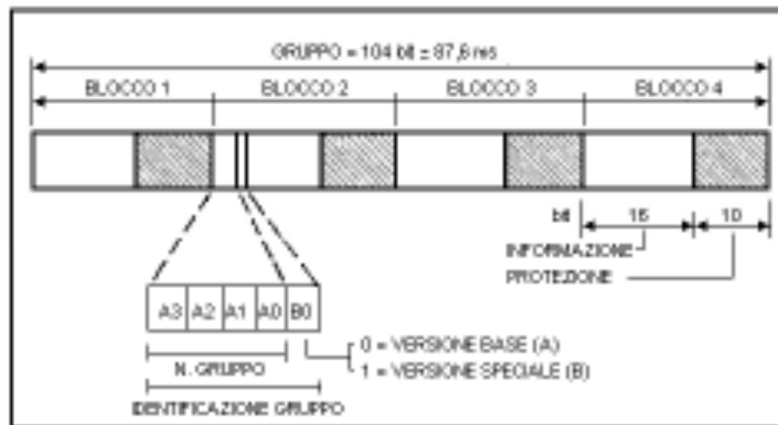


**Figure 3**

The system satisfies the protection ratios specified by the CCIR for mono and stereophonic transmissions.



**Figure 4**  
 Protection ratios for FM radiophony (max. deviation: ± 75 KHz)  
 Fig.5 shows the protection ratio curves for the three services.



**Figure 5**

The structure of the data signal is shown in fig.5.

Base-band structure of Radiodata

The structural element is the "group" containing 104 bits.

Each group comprises 4 blocks of 26 bits each, of which 16 are information and 10 are for protection.

Each block is directly identifiable by an 8 bit word which is summed in module-2 with the 10 protection bits.

The transmission is completely synchronous and there are no interruptions between consecutive groups and blocks.

Each block is protected by a self-synchronizing, compressed, cyclical code (26,16), having the following properties:

DETECTS ALL SINGLE AND DOUBLE ERRORS;

DETECTS ERROR STRINGS OF UP TO AND INCLUDING 10 BITS;

DETECTS APPROXIMATELY 99.8% OF ERROR STRINGS OVER 10 BITS LONG.

The code (26,16) performs well in correcting error strings which occur frequently in in-car

reception.

All error strings of upto 5 bits can be corrected.

It should be noted that the correction of reception errors implies a finite possibility of accepting as correct, an incorrect message that has not been detected.

There is a choice, therefore, between simple error detection which will not recover the message and full error correction which will do so.

From the results of reception tests carried out in Sweden, it would seem that the optimum decoding strategy, both for domestic as well as in-car reception, requires correction of single errors and adjacent double errors and the detection of long error strings.

The application of the error detection and correction code is however left to the receiver manufacturer.

Features RDS

The principal features of this encoder are as follows:

- 50 PSN
- 100 AF LISTE
- RS 232 C
- DATE, HOUR and CT
- RADIOTEXT
- TA - PTY - MS
- Fast tuning and switching information
- Traffic Message Channel
- Enhanced Other Network
- Linkage Information
- Language Identification Code
- Extended Country Code
- Application Identifications
- Program Type Name
- 19 KHz Input available on the rear panel
- Command TA - TA EON 0 - TA EON 1 - TA EON 2 - TA EON 3 - TA EON 4 - MS - RDS OFFremote

available on the rear panel via Cannon 25 pin connector

- Enabling of transmitted groups (eg. RDS - CT - RADIOTEXT)
- Control of leap years
- RDS signal level adjust

### **Applications**

Radiodata (RDS) has been developed principally for transmitting tuning information, such as the channel identifier, for the control of radio networks and the control of basic functions of the new generation of radio receivers. It also, however, offers basic ARI functions for in-car reception besides many interesting possibilities for domestic radio reception.

For example, it will be possible to transmit a commentary to the main program, as a RADIOTEXT message comprising text made up of alphanumeric characters (ASCII) that will appear on a display integrated into the receiver, and ultimately be able to control a voice synthesizer.

It is also possible to use Radiodata for the distribution of computer software.

It will thus be possible for software users to record software transmissions without the inconvenience of often extended interruptions to the main program being transmitted.

## **General Description**

### **Definition of terms**

THE FOLLOWING LIST OF DEFINITIONS RELATE TO THE STANDARDIZATION SPECIFICATION ANTERIOR TO THE EBU TECHNICAL DOCUMENT - TECH. 3 2 4 4 - E AND CENELEC FOR EN 5 0 0 6 7 .

#### **Program Identifier ( PI )**

This is a code which enables the receiver to distinguish the country of origin and the identification of the transmitted program.

The most important application of this information is the ability for the receiver to search automatically for alternative frequencies in the event of bad reception of the program to which it is tuned.



The change of frequency happens when a better signal with the same code of PI (program Identifier) is found.

**Program Service name ( PSN)**

This function allows transmission of messages upto a length of eight alphanumeric characters which can be used by the receiver to display to the listener the name of the currently tuned station and other information.

The Program Service name is not used for automatic searching.

**Traffic Program identifier ( TP)**

This is a function that identifies stations which transmit traffic information to drivers by, for example, changing the colour of the receiver's display.

**Alternative Frequency list ( AF)**

This function allows lists comprising 25 alternative frequencies to be transmitted. The receiver can thus hop automatically to the best reception frequency of the transmission.

**Traffic Announcement identifier ( TA)**

When this function is enabled by the station, the receiver will switch automatically from cassette to radio listening.

The car radio, as well as being tuned to the station transmitting traffic announcements, has to be enabled to receive ARI INFO or TA.

Once the announcement has been made, the radio automatically reverts to cassette listening.

This function is analogous to ARI.

**Program Type ( PTY)**

This function allows a code corresponding to the type of program to be transmitted with the program in order to identify it.

This service is not yet available on all receivers, but will eventually allow the receiver to be programmed to record certain types of program.

31 categories of program have already been defined by the EBU and are listed as follows:

0. No program type or undefined

1. News

2. Current Affairs

3. Information

4. Sport

5. Education

6. Drama

7. Culture

8. Science

9. Varied

10. Pop music

11. Rock music

12. M.O.R. Music

13. Light classics

14. Serious classics

15. Other music

16. Weather

17. Finance

18. Children's programs

19. Social Affairs

20. Religion

21. Phone-In

22. Travel

23. Leisure

24. Jazz Music

25. Country Music

26. National Music

27. Oldies Music

28. Folk Music

29. Documentary

30. Alarm Test

31. Alarm

### **Decoder Identifier ( DI )**

This function allows the identification of 16 different modes of operation including:  
monophonic transmission  
stereophonic transmission  
artificial stereophonic transmission  
processed mono  
processed stereo  
artificial processed stereo

### **Music / Speech (M/S)**

This function allows the program to be identified as music or speech.  
Compatible receivers will have two controls for independent volume adjustment of music and speech to the listener's preference.

### **Program Identification Number (PI N)**

This function allows selection of program type by the listener, such as light music, news or other.

### **Radiotext ( RT)**

This function allows the transmission of 64 characters addressed to domestic receivers equipped with a particular display.  
With in-car receivers, where it is not possible to display text for safety reasons, it may be possible in the future to communicate the radiotext message using a voice synthesizer.

### **Other Network information ( EON)**

This service allows control of the TA, TP, PTY and PIN functions of ten radio networks.

### **Transparent Data Channel (TDC)**

This service, which is similar to Radiotext, allows serial alphanumeric information, corresponding to computer software or other non displayable information, to be transmitted.

### **Clock Time ( CT)**

As per CCIR standards, information relating to time and date is defined by Coordinated Universal Time (UTC) and by Modified Julian Day (MJD).  
The listener will not have direct access to this information which will be used, internally, by the receiver.

### **Fast basic tuning and switching information**

Fast tuning service.

### **Traffic Message Channel**

This service is used to send traffic information through a specific channel.

### **Enanced Other Network ( EON)**

This service transmits network information.

### **Linkage Information ( LI)**

This information is transmitted together with the EON.

### **Language Identification Code ( LIC)**

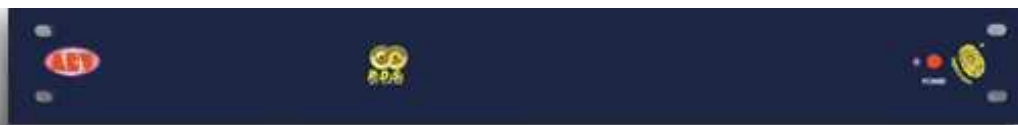
Language used by the radio station.

### **Extended Country Code ( ECC)**

Specify oncemore the country name in order to be recognized unequivocally beside the information already transmitted together with the PI.

## **Panels**

### **Front panel**



## Rear panel



### Description of rear panel controls

**1 . LINE INPUT**

**2 . 19 KHz IN**

Input connector 19 KHz pilot only.

**5 . MPX IN.**

Output connector for MPX signal.

**4 . MPX & RDS OUT**

Output connector for MPX + RDS signal

Multi-turn trimmer for level regulation from 0 to 700 mVpp

**5 . REMOTE**

Remote control connector

**6 . PRESET**

Dip-switch for baudrate and other function.

**7 . RS232**

Serial port connector

## Installation

The RDS 4500 installation manual should be read carefully to ensure correct use of the unit .

1 .The RDS 4500 encoder` should be installed between the stereo encoder and the transmitter. If the audio processor is to be used with an internal encoder, the RDS signal can be connected to the relevant connector on the encoder card.

Connections between units must be as short as possible since reactive properties of the connection cables will produce phase shifts on the multiplexed signal that will vary with frequency.

This will result in a reduction of stereo separation which can be severe. It is recommended that Connection cables do not exceed 3 metres in length.

2 .Position the encoder away from sources of heat. Avoid humid sites with extremes of temperature.

3 .Check that the line voltage is suitable for the RDS 4500 before connection with the cable supplied.

The voltage is selected internally and can be 220 VAC or 110 VAC (50/60 Hz).

4 . Take care to ensure that input and output connections are made properly since, in the majority of cases, hum and noise are caused by poor connections.

5 . Never use alcohol or chemical solvents to clean the unit as these can cause damage to the finish.

6 . Should the unit appear faulty, switch off, bypass the unit and contact your nearest AEV service center.

7 . Keep this manual for future reference and to avoid possible operational error.

**Failure to observe the above instructions will result in the immediate expiry of all guarantees.**

### Interconnection

The RDS data encoder must be connected between the stereo encoder and the transmitter. The stereo encoder's multiplex output should be connected to the **MPX IN** input of the RDS encoder.

The **MPX+ RDS OUT** output should be connected to the input of the transmitter.

It is advisable to keep cable lengths to less than 3 metres.

The injection of the **RDS** signal has been factory-adjusted for an **MPX** input level of 0 dBm (and a 19 KHz pilot level of -20 dB).

For higher input signal levels, turn the "RDS LEVEL" multi-turn potentiometer clockwise.

This will increase the RDS signal level.

International standards recommend an RDS level of -31.5 dB with respect to the stereo and consequently -11.5 dB with respect to the pilot.

No phase adjustment is required as synchronization is performed automatically by internal circuitry.

In the event of monophonic transmissions, the RDS data encoder should be connected between the last low frequency unit in the audio chain and the transmitter.

### RS232 Serial Port

The Serial connection RS232C is standard and has a 9 poles Cannon connector.

As per each RS232 connection, the length must not be superior to 20 m and the shielding must be adequate.

Anyway, it is possible to extend the connection at any time by using a couple of standard line extensors.

### Pc Software

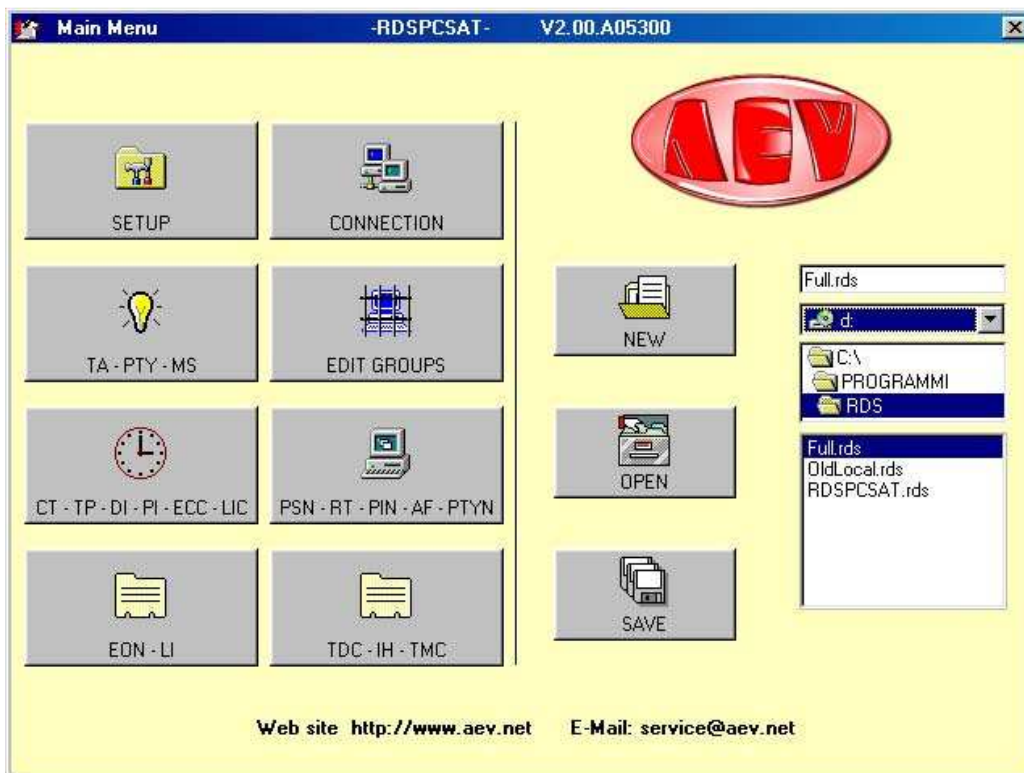
The RDS coder control program is supplied together with this handbook in CDROM version. It must be installed on a computer with CPU Pentium 266 or better and a Windows 95/98/XP version must be installed. The software cannot run without these configurations or, in the best of cases, it will run but will not be able to communicate correctly with the coder.

To install the program, go to the CDROM reader drive, and double click on the Setup.exe icon.

The program will be automatically installed and a link will be created on the program bar.

To execute the program, click on the **Start** button on the applications bar with the left button of the mouse. Select the Programs file, then the Rdspsat file. Now, using the mouse, click on the **Rdspsat** program.

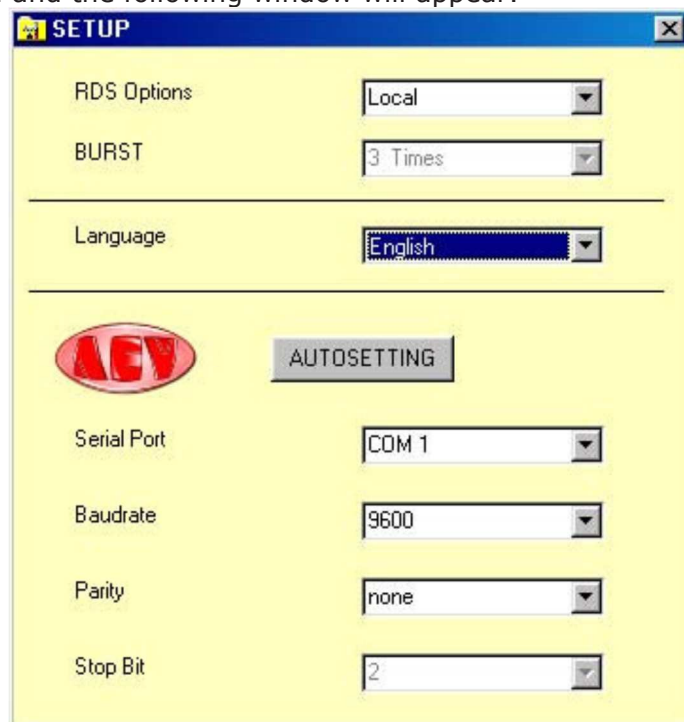
The following window will appear:



An error message may be received when the program is started for the first time, due to the default parameters set, which may not be suitable for your system. The parameters of the serial port must therefore be modified.



Select the RS232 icon and the following window will appear:



Let's now see the parameters and their meaning:

**- RSD Option**

this is used to choose whether a coder programmed **locally** or via **satellite** is involved. This choice affects all the programming windows and disables or enables certain functions. In the case of programming "via satellite", only the transmission function is available therefore all the reading push buttons will be disabled. A new push button called BURST will also be enabled, which automatically repeats the transmission performed a number of **Times**, equal to that set in the specific option.

This performance has been implemented to overcome the problem of any "MTF's" transmitted with the consequent incompleteness of the parameters sent.

**- BURST**

3 Times 4 Times ..... 10 Times as explained above, this parameter takes care of the transmission, repeating it 3, 4 ....10 times.

**- LANGUAGE**

Choice of the operational language.

**- AUTOSETTI NG**

This push button is enabled only in the "Local" configuration and automatically searches the communication parameters of the serial port. It may in any event always be entered manually.

**- Ser ial Por t**

Choice of the communication port: COM1, COM2, COM3 or COM4.

**- Baudrate**

Choice of the transmission speed. It must be set according to all set on the dipswitches of the coder.

It may assume the following values: 2400, 4800, 9600 or 19200

**- Parity**

Choice of the parity, which may take on the following values: none, even or odd

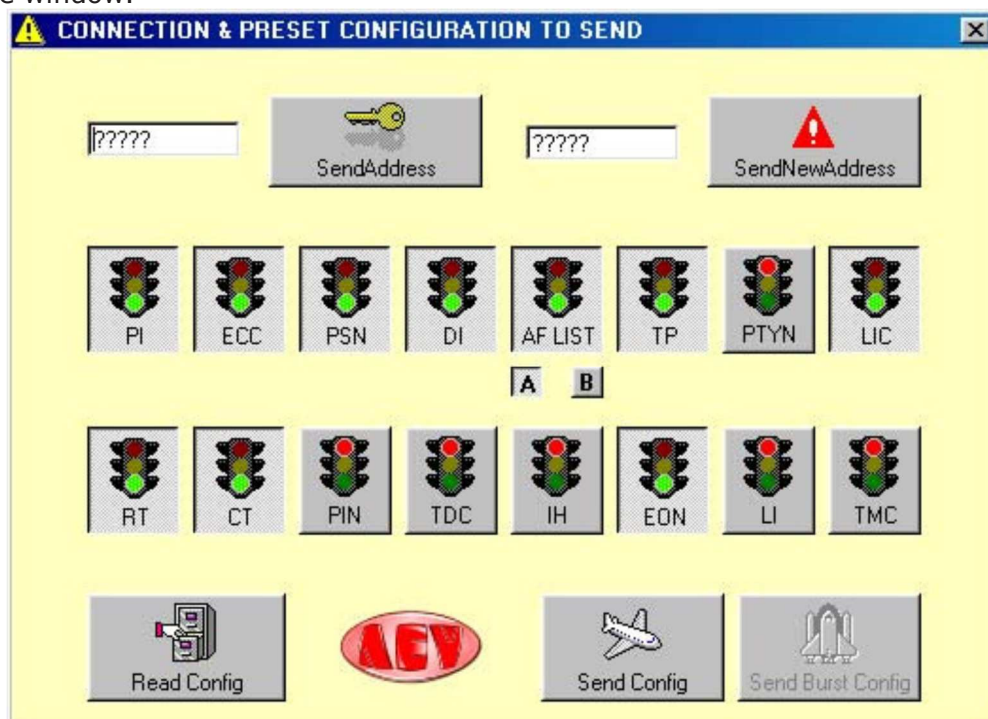
**- Stop Bit**

This parameter may not be altered. It is used to display the status of the "Stop Bit".

For connections in downlink from satellite mode, a baud rate of 9600 must be set unless requested otherwise in the technical specifications of the satellite downlink..

Once the communication parameters have been set, communication must be enabled with the coder, by sending it an address (default setting=?????).

Press the **Connection** push button to gain access to the code send and change menu, together with a set of push buttons used to send or read certain categories without entering the appropriate window.



Let's see the parameters and their meaning.

A box at the left hand part is displayed where the coder address is entered. The default address is ??????.

The **Send Address** push button at the side of this text box is used to activate the coder for programming, whether this is done "locally" or "via satellite".

Another text box and a push button on the right hand part are used to change the address of the coder (this operation is normally done only for applications via satellite).

16 push buttons are available (On/Off), which gather the functions of the RDS coder. The functions in ON status (green traffic light) can be transmitted or read simultaneously.

Two small square push buttons under the AF switch are used to select the type of transmission of the alternative frequencies.

The small **A** push button is used to program a single list made up of a maximum of 25 frequencies, which are reduced by one each time the frequencies type xxx.250, xxx.750 are enabled. This is the only system that allows the enabling of frequencies with 25KHz steps.

The small **B** push button is used to program up to 50 lists, each of which is made up of a maximum of 12 pairs of alternative frequencies.

Three push buttons are available in the part underneath. In "local" configuration, **Read Config** and **Send Config** will be enabled, which are used to send or to read the options selected by means of the "traffic lights". In "satellite" configuration, **Send Config** and **Send Burst** will be enabled, which are used to send the options selected by means of the "traffic lights".

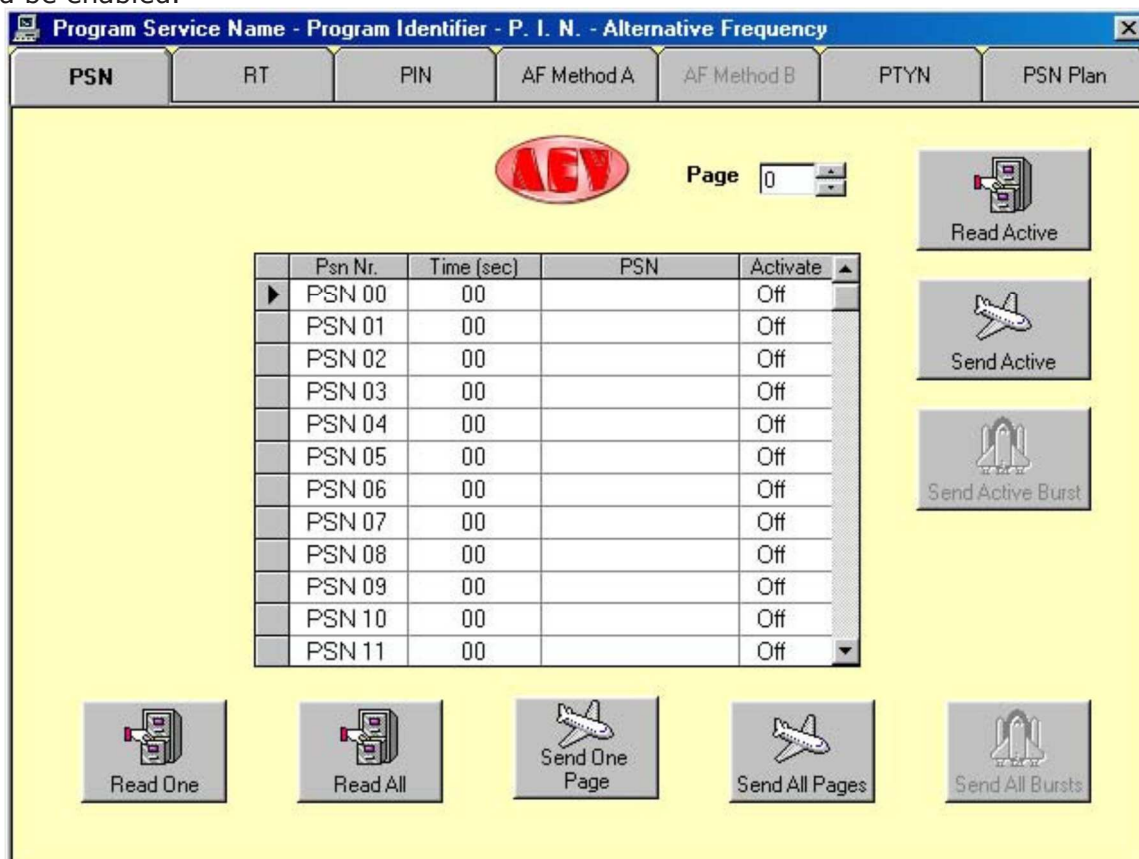
Exit this menu to return to the main Menu.

At this stage, it is a good rule to save the parameters set so far using the relative push buttons. **NEW** is used to create a new file (with the default parameters), **OPEN** to open an existent file and **SAVE** to save the file in use or to re-name it. It is advisable to give the

configuration file (rds), a name different from RDSPCSAT.rds, OldLocal.rds and Full.rds as these are the names of those already existing.

Let's analyse the PSN-RT-PIN-AF-PTYN push button parameters. From the main menu, by pressing the push button with a PC, a menu of boards will appear. By clicking on the tab of the board, the option to be modified can be selected. The first board illustrated will be that of the Program Service Name.

From here onwards all the windows that appear will refer to a "local" coder. If we were working in the via "satellite" mode, all the Read's would be disabled, whereas the Burst push button would be enabled.



Up to 50 PSN's can be programmed. Programming is quite simple. Enter the **Time (sec)** (transmission time in seconds) of each PSN (it is advisable to enter a time of less than 3 sec). Edit the PSN, which may have a length of 8 characters, including spaces. Finally enable the PSN by double clicking on the **Activate** box of this PSN.

The number of the PSN page can be selected in the Page box (from 0-9), which can be sent to the RDS by programming the PSN Plan.

Let's see what the push buttons are used for.

**Read One** reads the PSN selected.

**Read All** reads all the PSN's of the page selected.

**Send One Page** sends the PSN selected.

**Send All Page** sends all the PSN's of the page selected.

**Read Active** reads the page being transmitted by the rds coder.

**Send Active** sends the page displayed, which will be immediately transmitted on the rds coder.

Let's examine the programming of the Radio Text. As described earlier, click on the board Radio Text tab.

The following window will be displayed.

RT Nr.	Time (sec)	Radio Text
RT 00	0	
RT 01	0	
RT 02	0	
RT 03	0	
RT 04	0	
RT 05	0	
RT 06	0	
RT 07	0	
RT 08	0	
RT 09	0	
RT 10	0	
RT 11	0	
RT 12	0	
RT 13	0	

Following the same programming procedure as that for the PSN, enter the transmission Time (sec) of the string of characters then, in the Radio Text box, enter the text of up to 64 characters. Up to 50 strings can be entered.

Let's now analyse the options of the P.I.N. board.

PIN Number	Day	Time	Program Type	PIN	Issued
PIN 00	00	00.00	No program type or undefined	0000	No
PIN 01	00	00.00	No program type or undefined	0000	No
PIN 02	00	00.00	No program type or undefined	0000	No
PIN 03	00	00.00	No program type or undefined	0000	No
PIN 04	00	00.00	No program type or undefined	0000	No
PIN 05	00	00.00	No program type or undefined	0000	No
PIN 06	00	00.00	No program type or undefined	0000	No
PIN 07	00	00.00	No program type or undefined	0000	No
PIN 08	00	00.00	No program type or undefined	0000	No
PIN 09	00	00.00	No program type or undefined	0000	No

Enter the date of the **Day** when the programming is to be made.



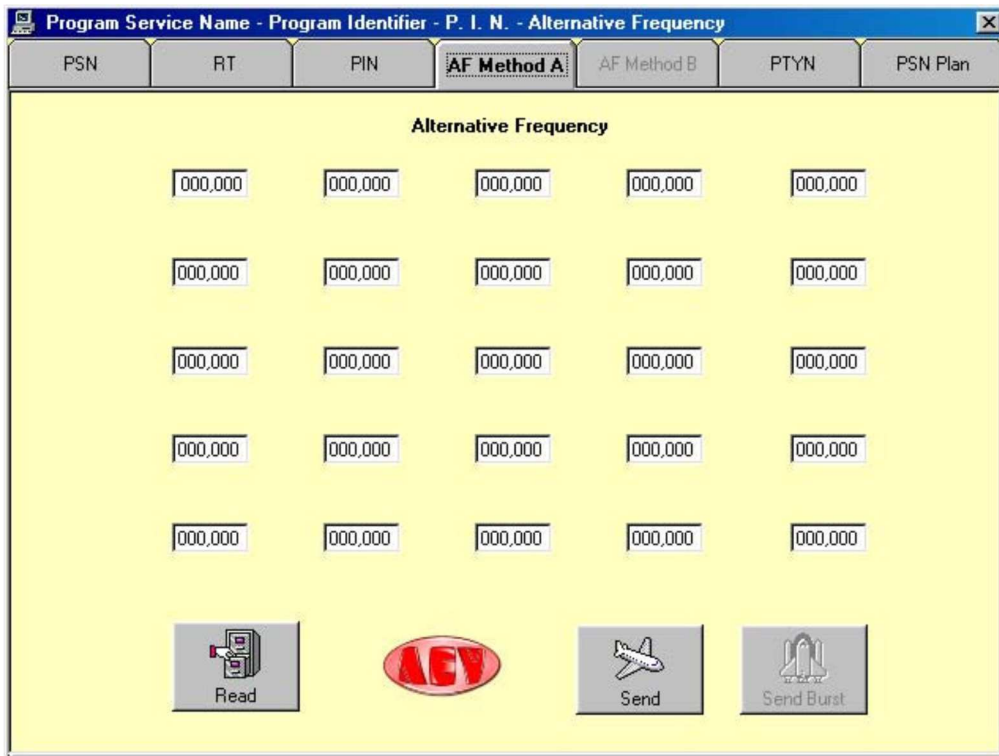
Enter the programming beginning **Time**.

Select the programming mode amongst those offered. Now, going on to a new setting, the 4-figure PIN code will automatically be created. The last box shows whether the setting has already been made (Yes) or whether it is still to be processed (No).

Two different boards for programming the alternative frequencies will now be shown, according to the mode selected: AF Method A or AF Method B.

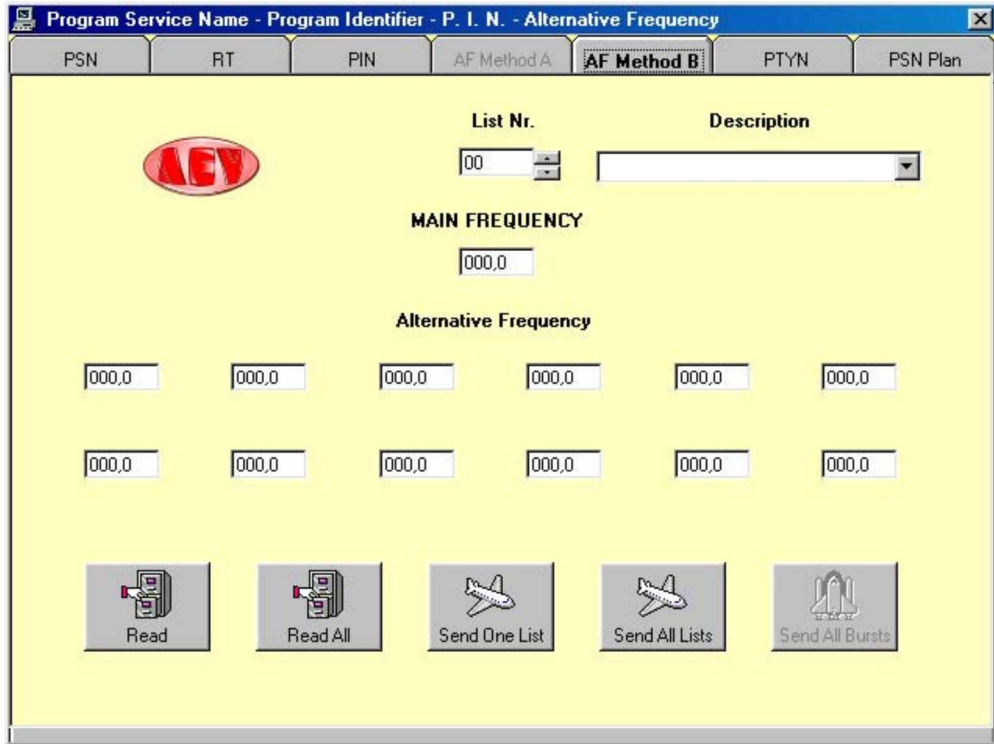
Bear in mind that the use of one method excludes the other.

Let's now analyse the **AF Method A** board.



This board consists of 25 frequencies. **Only** with this method will it be possible to enter frequencies with steps of 25 KHz. The last of this type of frequency causes the loss of another frequency: therefore up to 25 frequencies with steps of 50 KHz can be entered or 12 frequencies with steps of 25 KHz or in a combined manner, taking all explained earlier into account.

Once all the frequencies have been entered, the setting can be sent to the coder using the Send push buttons. If the "local" mode is being used, the parameters already set may also be read.

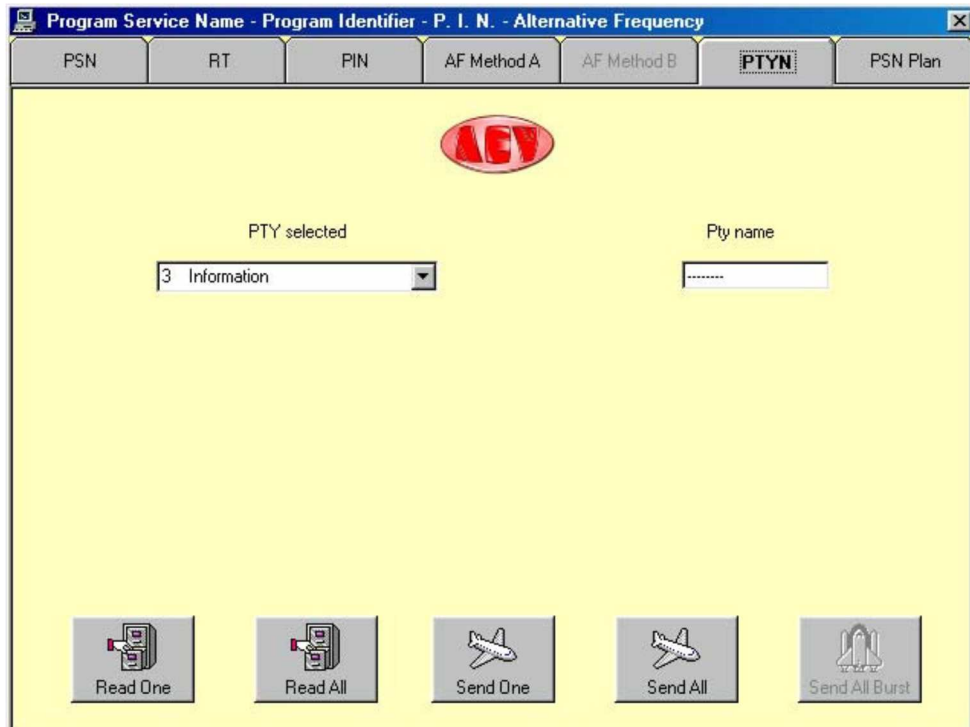


Method B enables the entry of frequencies with steps of 50 KHz. Up to 50 groups of alternative frequencies can be entered. Each group can bear up to 12 alternative frequencies, plus the main frequency.

To make the setting, select the list desired. A comment concerning this group can be entered in the **Description** field. Enter the **MAIN FREQUENCY** then the alternative frequencies in the other boxes.

Once a list has been completed, it can be sent as a single list or in one go.

Likewise in "local" mode, one or all the lists can be read using the Read push buttons.



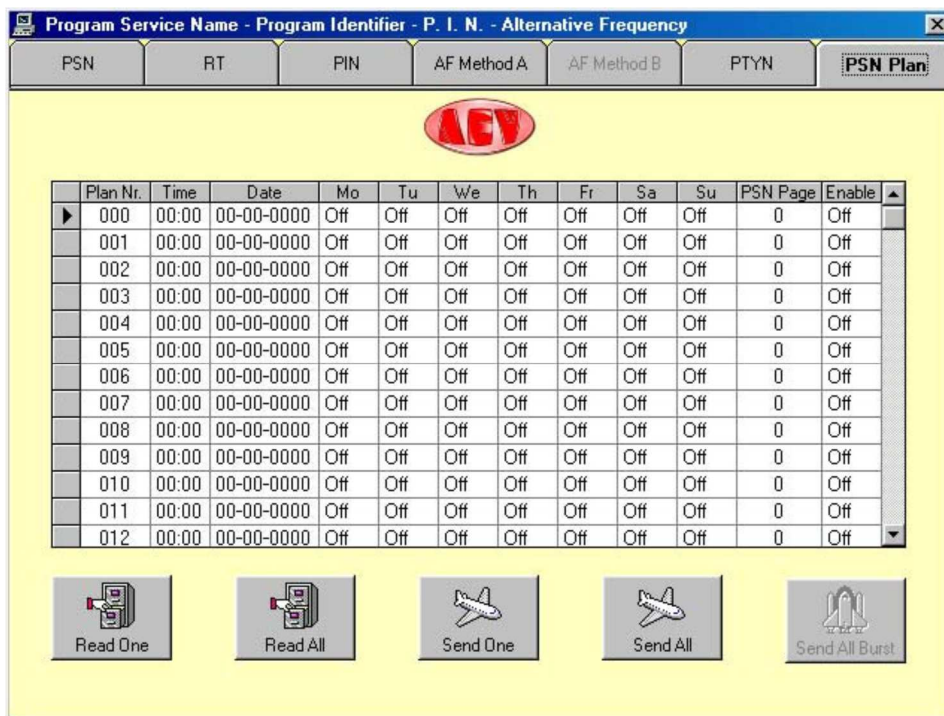
The PTYN is an extension of the PTY. Once the PTY type has been selected, enter the

## AEV AEV RDS 4500 – rds encoder

specification of that type in the right box. 8 characters at the most can be used.

For example PTY sport, Name football.

Let's now analyse the menu used to set the Program Service Name.



Up to 200 settings can be programmed using this menu.

For example: we want to broadcast page 7 at 10:30 on the 14th June 2000.

In this case, as it is the first setting, select the Plan Nr.000 line, enter 10.30 in the Time box, then 14-06-2000 in the Date box and then in the PSN page, enter the page bearing our setting 7 and finally enable the setting, Enable On.

Again, for example: we want to broadcast page 5 at 12:00 every Wednesday.

In this case, select the Plan Nr.011 page, enter 12:00 in the Time box and click on Wednesday and then in the PSN page, enter the page bearing our setting 5 and finally enable the setting, Enable On.

If previous settings have not been made, then the last one entered will be saved.

Let's go back to the main board, press push button CT-PI - ECC - LIC - TP - DI, to gain access to the Clock Time board.

The screenshot shows the 'Clock Time' window of the AEV RDS 4500 software. The window title is 'Clock Time - Traffic Program - Decoder Identifier - Program Identifier'. The interface includes a calendar for May 2000, a time display set to 11:14, a CT OFFSET set to +01.0, a DATE PSN set to 99, and an HOUR PSN set to 98. There are 'Send' and 'Read' buttons on the right side of the interface.

Sun	Mon	Tue	Wed	Thu	Fri	Sat
30	1	2	3	4	5	6
7	8	9	10	11	12	13
14	15	16	17	18	19	20
21	22	23	24	25	26	27
28	29	30	31	1	2	3
4	5	6	7	8	9	10

HOUR-MINUTE: 11:14

CT OFFSET: +01.0

DATE PSN: 99

HOUR PSN: 98

Buttons: Send, Read

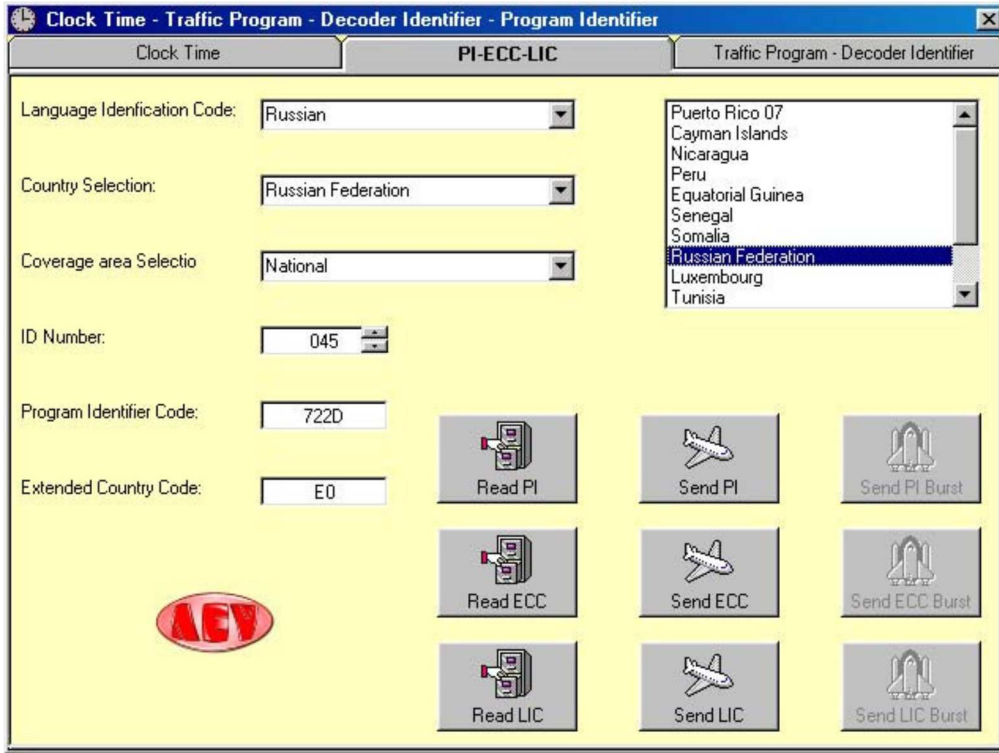
. In a very simple manner, the date and time can be assigned.

The CT OFFSET function is used to enter the time zone difference, (this function is normally used in America).

The DATE PSN function is used to decide in which PSN the date must appear.

The HOUR PSN function is used to decide in which PSN the time must appear.

The Send push button is used to send the update to the coder, whereas the Read push button is used to read the information previously set.

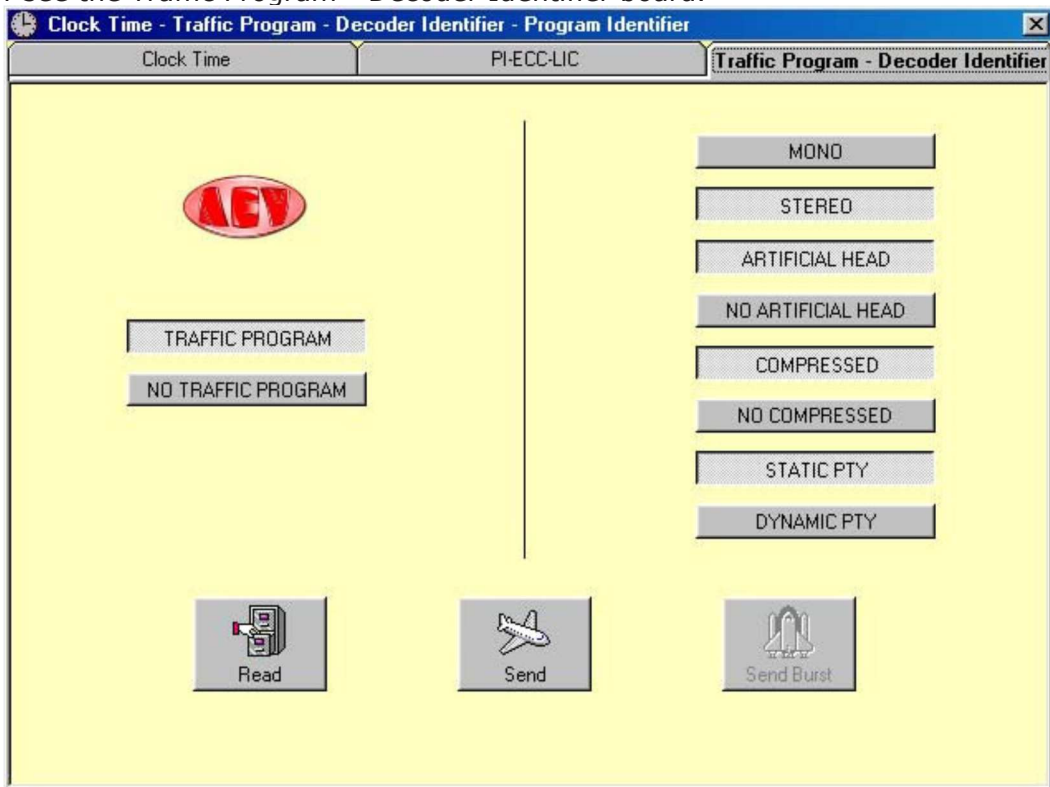


In the following board, the parameters of the Program Identifier can be entered together with relative further extensions.

The first setting to be made is the type of language used in transmission (Language identification Code), then select the country (Country Selection), then the type of coverage (Coverage area Selection) and finally the ID.

The Extended Country Code and the right table are displayed together. The Send push buttons are used to send the update to the coder, whereas the Read push buttons are used to read the information set previously.

Let's now see the Traffic Program - Decoder Identifier board.

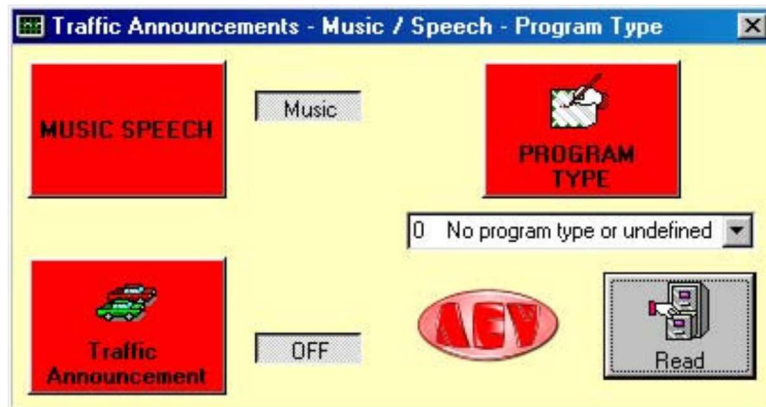


The TP option can be selected on the left side. The options relative to the type of

## AEV AEV RDS 4500 – rds encoder

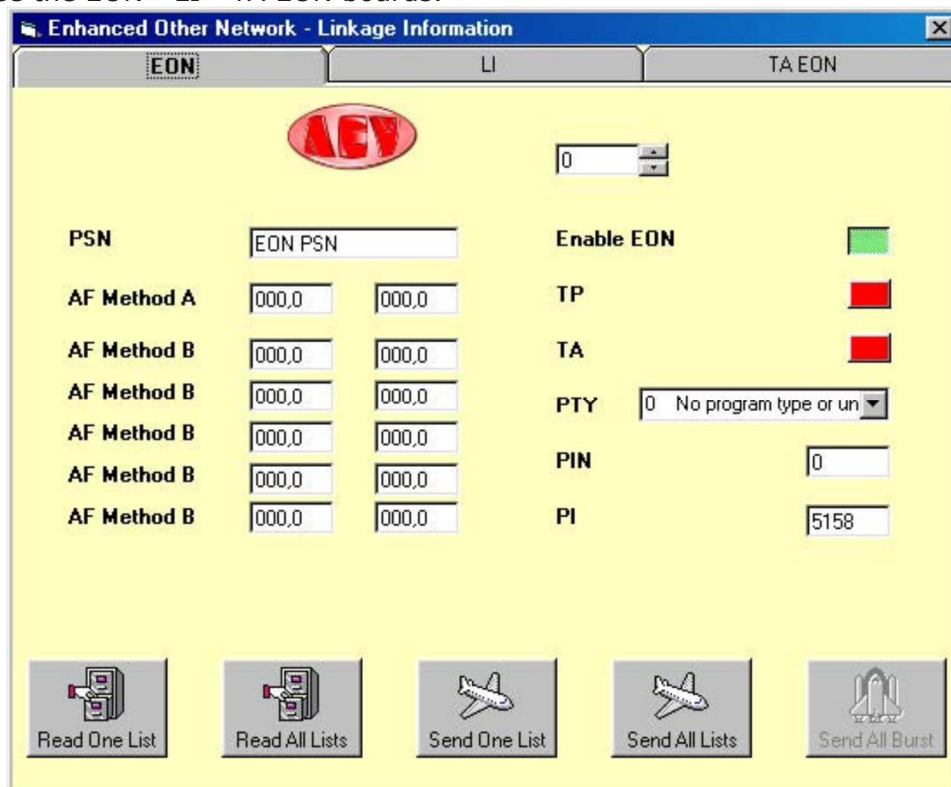
transmission are available on the right side. Once the choices have been made, sent the update to the coder using the Send push button. Use the Read push button to read the information set previously.

Let's now see the "live" controls window.



.Press any one of the red push buttons to immediately transmit the functions in use to the coder, with the exception of Program Type. To do this, make the selection using the combo box and then press the relative push button. The Read option is enabled only in "via satellite" mode.

Let's now see the EON - LI - TA EON boards.



10 pages are offered to make the required settings.

Depending on the properties of the network, the parameters are entered, then in the same manner as the other boards, the parameters are read or sent to the coder using the Read and Send push buttons.

Let's now see some examples to better explain how to make the settings.

Supposing we have radio MISS, which must make the setting with method A with radio JOY and with radio SUN.

Radio JOY has PI 5155 and frequencies 102.0 and 106.5, radio SUN has PI 5159 and frequencies 100.0 and 104.5.

Select page no. 0, enter the name of the first radio in the PSN box, in our case radio JOY (8

## AEV RDS 4500 – rds encoder

characters at the most can be entered in any event). Now enter the two frequencies in the boxes at the side of AF Method A writing, in our case 102.0 and 106.5 in the second box. Finally enter code 5155 in the PI box.

Let's now program the second radio connected. Select page number 1, enter the name of the radio in the PSN box, in our case radio SUN, enter the two frequencies in the boxes at the side of AF Method A writing, in our case 100.0 and 104.5 in the second box. Finally enter code 5159 in the PI box.

At this stage simply send the setting to the rds coder.

To make the setting with method B, proceed in the same manner.

Radio MISS has frequencies 90.5, 91.0 and 93.5, 94.0, radio ABC has PI 5156 and frequencies 89.0, 102.0, 103.5 and 106.5, radio BOYS has PI 5160 and frequencies 98.0 e 100.5.

Select page number 0, enter the name of the first radio in the PSN box, in our case radio ABC. Now enter the frequencies in the boxes at the side of AF Method B writings, the frequencies of radio MISS are entered in the first column, those of the associated radio in the second, relative to the same coverage areas, in our case those of radio ABC.

90.5 102.0

91.0 103.5

93.5 106.5

94.0 89.0

Then enter code 5156 in the PI box.

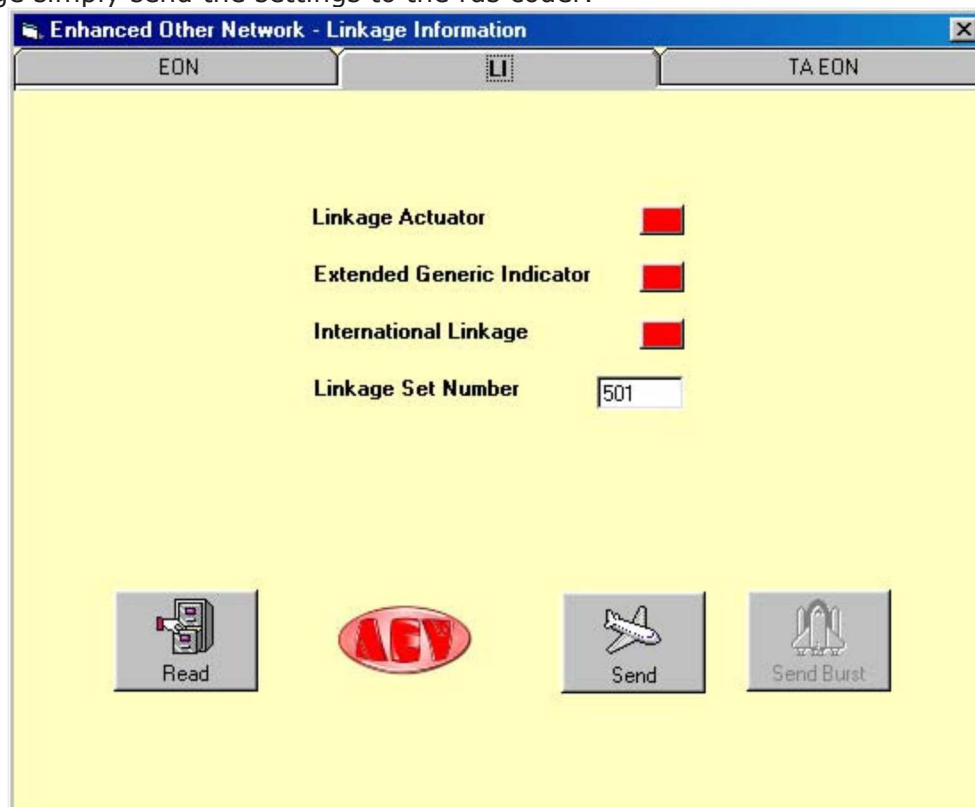
Make the same settings in page 1 for radio BOYS, enter the name of the radio in the PSN box, in our case radio BOYS, then complete the frequencies boxes, bearing in mind, as said above, that those on the left side relate to radio MISS and those on the right side to radio BOYS.

90.5 100.5

93.5 98.0

Then enter code 5160 in the PI box.

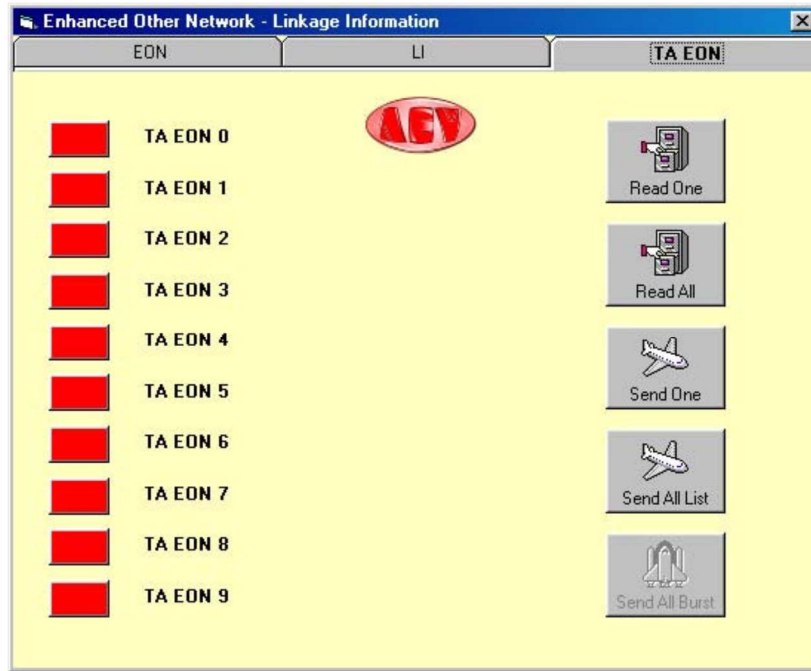
At this stage simply send the settings to the rds coder.



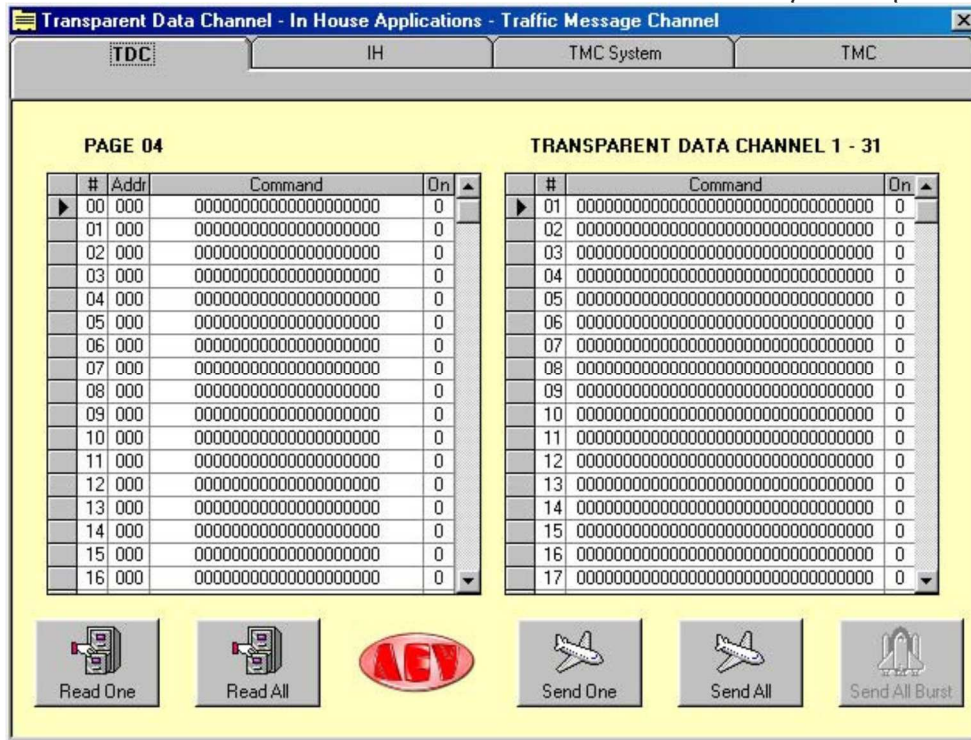
From the Linkage Information board, some parameters relative to the network transmission can be attributed. In particular using the Linkage Actuator push button, the network connection activation command is sent, the Extended Generic Indicator, which is a command not yet used, the International Linkage, which establishes whether the connection in use is of the national or international type and finally the Linkage Set Number which is the connection code.

We have still another board, TA EON, which is used only to send all the TA EON selected all

together.

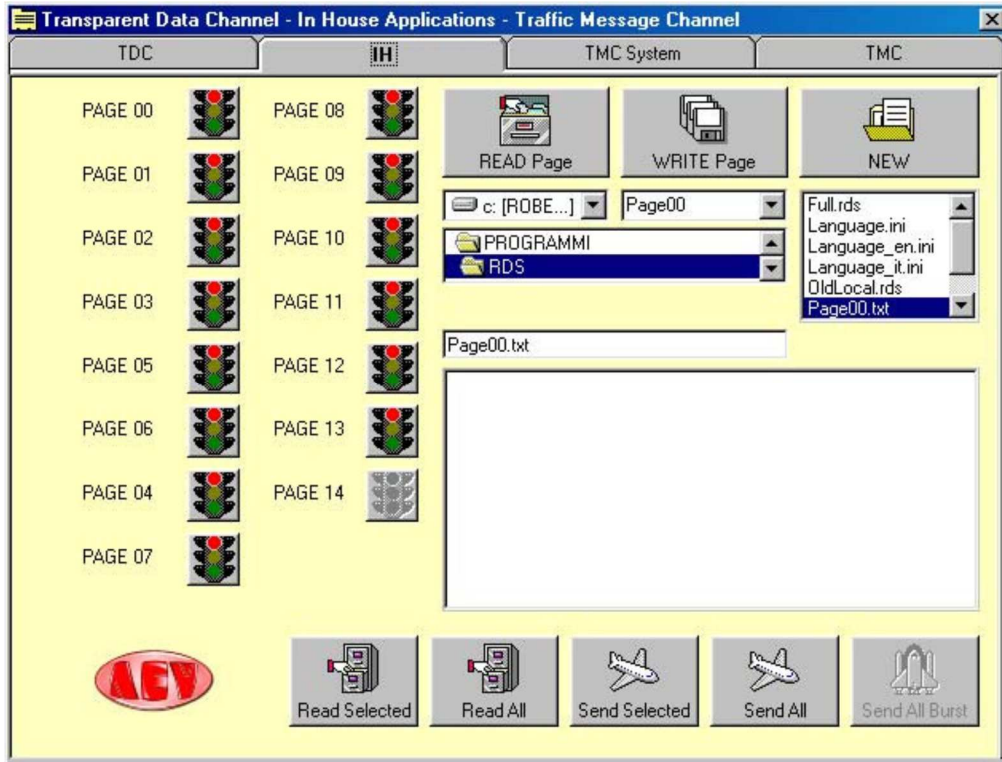


The last functions available relate to the Transparent Data Channel, to the In House Applications and to the Traffic Message Channel. These functions have been designed in compliance with the Cenelec EN50067 standards and can be used only with special decoders.

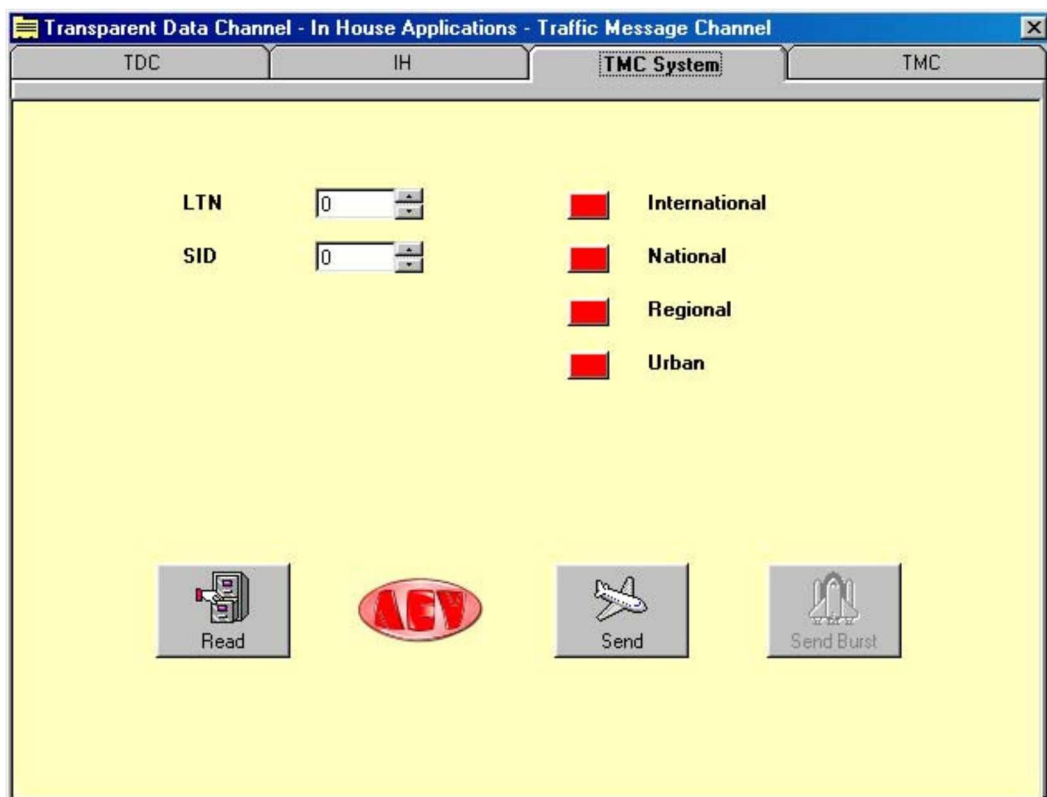


100 remote controls are available for the **Transparent Data Channel**, whereas 31 remote controls are available for the Channels from 1 to 31. As usual, the Send and Read push buttons are used for the usual functions.





The pages available are pointed out by the lighting up of the relative traffic light. To modify a page, retrieve it using the combo box. From the editing window, make the desired modifications and then save the page using the Write Page push button or send it using the Send push buttons. A special decoder is required for this application too.

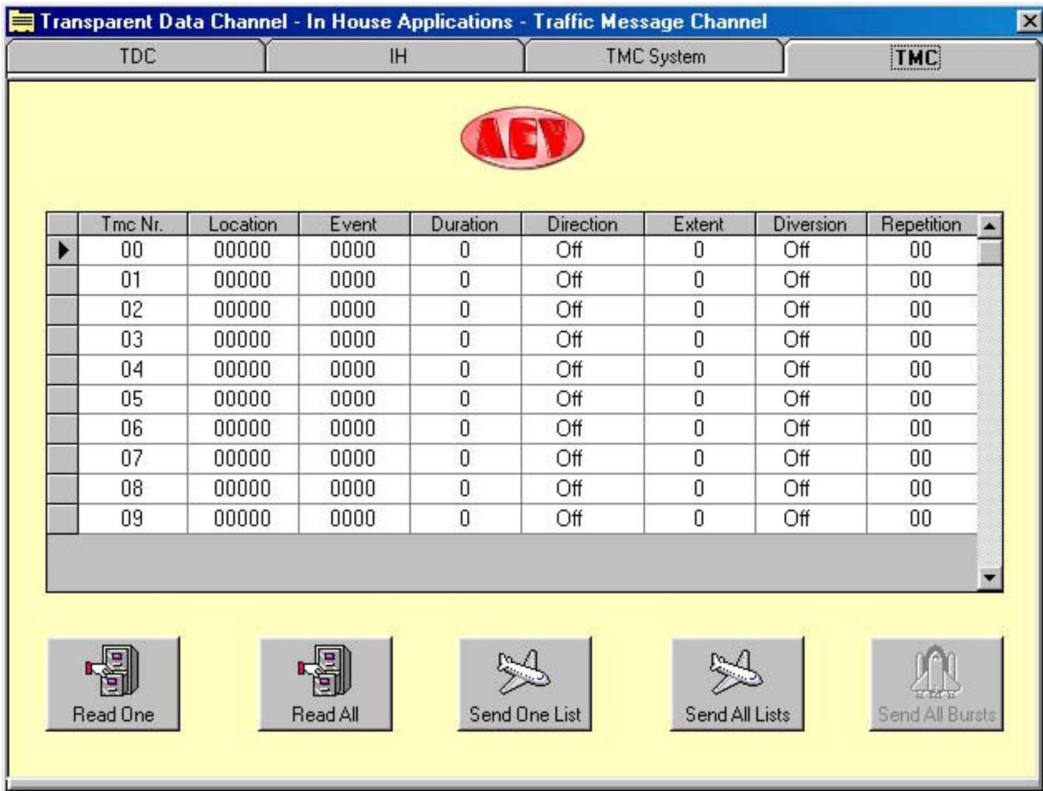


In the two tables relative to the Traffic Message Channel, refer to the CEN TC 278 SWG7.3 E pr ENV/278/7/3/004 of the CEN TC 278 WG7 for the specific codes.

## AEV RDS 4500 – rds encoder

The LTN code is found in this board, Location Table Number, together with the SID Service Identifier, plus the setting of the coverage area, which can be considered as an identification code of the sender, similar to the PI.

All parameters required for the event description are provided in the following board. Let's see the board.



The screenshot shows a software window titled "Transparent Data Channel - In House Applications - Traffic Message Channel". The window has a yellow background and a red AEV logo at the top center. Below the logo is a table with 9 rows and 8 columns. The columns are labeled: Tmc Nr., Location, Event, Duration, Direction, Extent, Diversion, and Repetition. The data in the table is as follows:

Tmc Nr.	Location	Event	Duration	Direction	Extent	Diversion	Repetition
00	00000	0000	0	Off	0	Off	00
01	00000	0000	0	Off	0	Off	00
02	00000	0000	0	Off	0	Off	00
03	00000	0000	0	Off	0	Off	00
04	00000	0000	0	Off	0	Off	00
05	00000	0000	0	Off	0	Off	00
06	00000	0000	0	Off	0	Off	00
07	00000	0000	0	Off	0	Off	00
08	00000	0000	0	Off	0	Off	00
09	00000	0000	0	Off	0	Off	00

Below the table are five buttons: "Read One", "Read All", "Send One List", "Send All Lists", and "Send All Bursts".

The Location parameter is used to establish where the event has occurred.

The Event parameter establishes the type of event.

The Duration parameter establishes how long the event lasts presumably.

The Direction parameter establishes the direction in which the event has occurred.

The Extent parameter establishes additional specifications concerning the place in which the event has occurred.

The Diversion parameter establishes alternative routes.

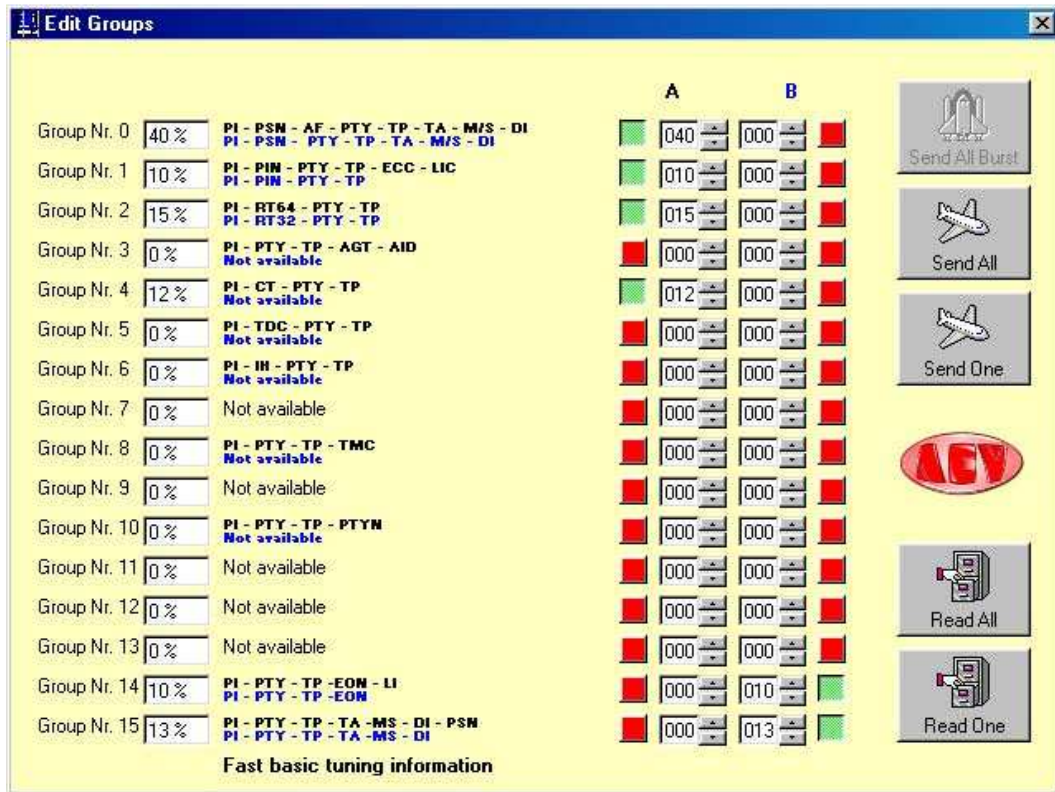
The Repetition parameter establishes the repetition percentage of this compared to the other events pointed out.

The last board available in this program is called Edit Group. This function is normally disabled as it allows the transmission percentages of the groups to be altered. Therefore, if unsuitable modifications are made, there is the risk that the information is not transmitted correctly.

Proceed as follows to enable this function: save the configuration file "nome.rds" with a Notepad text editor. Open the "nome.rds" file. Type-in **On**, in the EnableGroupFunction=**Of** item.

Then save the file and open it again using the Open command from the main window of the program.

**Do not make any other modifications in this file, otherwise errors may be produced in the program.**



. 15 groups, split-up into A/B are available.

At the side of each group, an ON/OFF push button is available. If it is red it means that the group is disabled and if it is green it means that it is enabled.

The box with numbers indicates the transmission value of the group.

The default values are:

**Group 0 A On 0 4 0**

**Group 1 A On 0 1 0**

**Group 2 A On 0 1 5**

**Group 4 A On 0 1 2**

**Group 1 4 B On 0 1 0**

**Group 1 5 B On 0 1 3**

**Do not make any modifications unless you are absolutely certain.**

**3 types of configurations have been pre-arranged:**

**RDSPCSAT.rds** loaded default configuration with all the most frequently used parameters.

**OldLocal.rds** to be used only with previous versions of RDS 3500 and STARGATE MK1 (they may be identified by the two 9-pin connectors on the back of the panel).

**Full.rds** this configuration is used to modify all the parameters of the RDS coder.

## Electrical Specifications

### RDS Generator

RDS signal: Standard specification EBU Doc. Tech. 3244-E and Cenelec PrEn 50067

Coding: Differential and Biphasic

Modulation: DSB-suppressed carrier

Frequency: 57 KHz

Bandwidth: ± 2.4 KHz

RDS injection into MPX signal: - infinite ÷ - 16 dB

RDS output level: 0 dBu

Output Impedance: 100 ohm (max load 5 Kohm)

Connector: BNC grounded to chassis

### Data Synchronization

Terminal Interface: RS232-C at rear, asynchronous

**AEV AEV RDS 4500 – rds encoder**

Data Input Full duplex  
Format Selectable  
Transmission Speed 2400 ÷ 19600 baud  
Connector 9 contact subminiature cannon female  
RDS Data management Microprocessor controlled 128 Kbyte  
Non volatile memory RAM data retention 10 years.

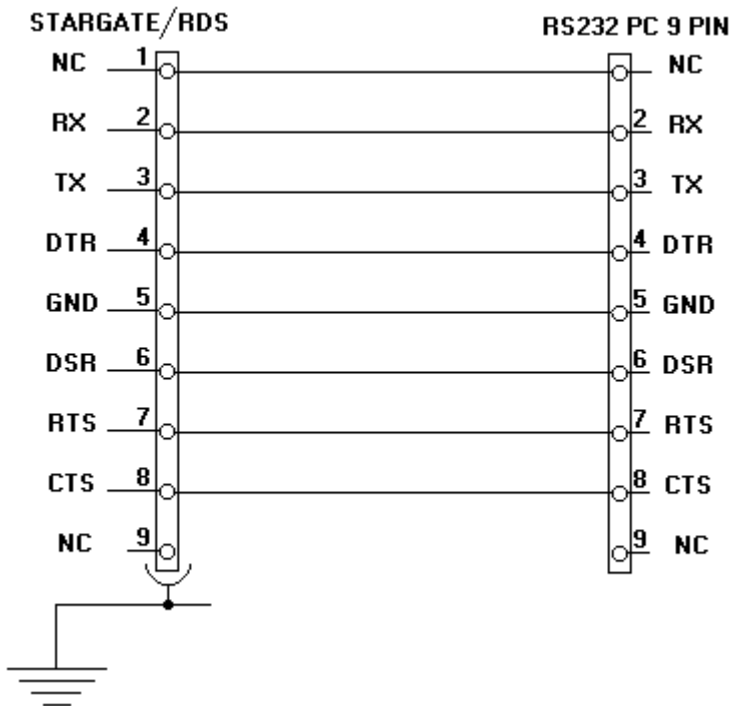
**Remote I / O**

MS, TA, RDS OFF Cmos level  
Connector 25 pin subminiature cannon female

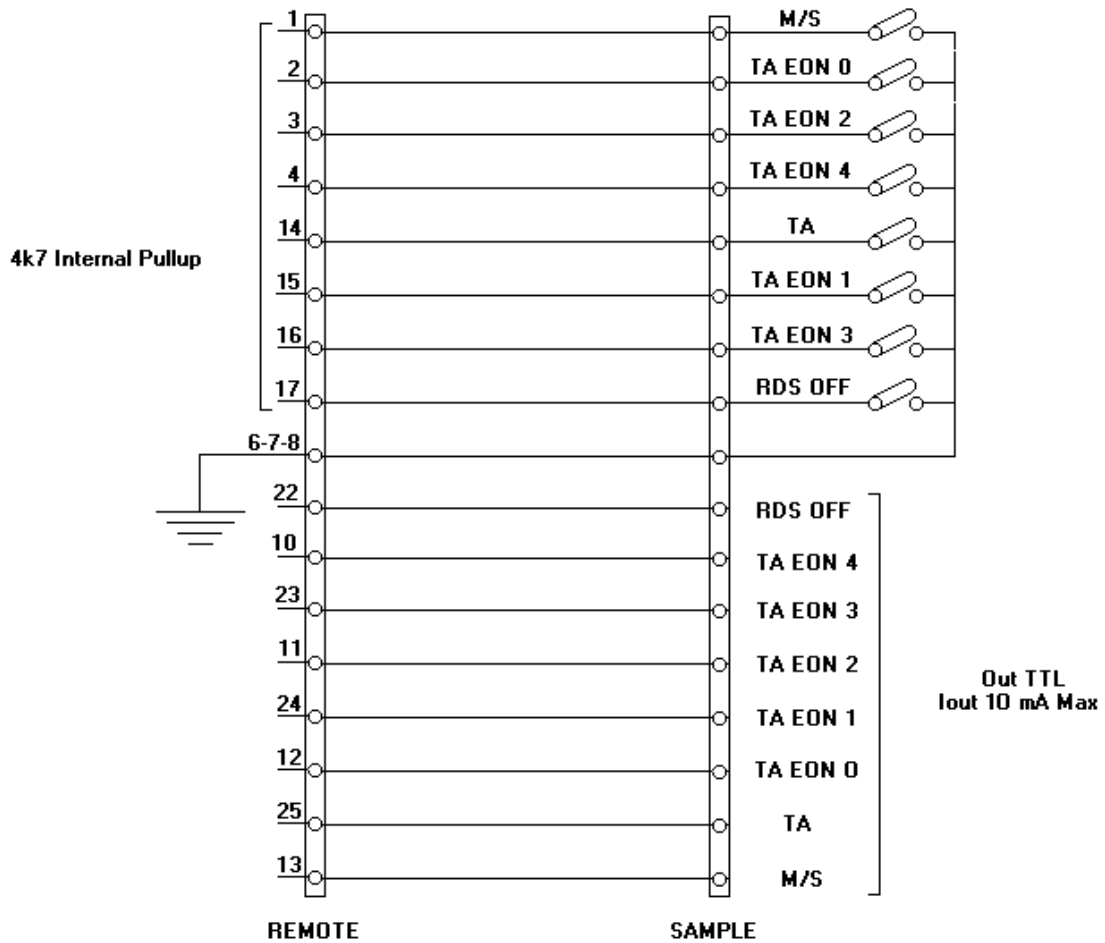
**General Data**

Power requirement 87 ÷ 265 VAC 50 ÷ 60 Hz  
Consumption 8 VA  
Dimension (WxHxD) 48.3 x 24 x 4.4 cm 1 rack unit  
Weight 2,5 Kg. (5.5 Lbs)  
Operating Temp. 0 ÷ 50° C

**Connect ion PC - RS232**



**AEV RDS 4500 – rds encoder**  
**Sample connection Remote**



**Jumper & Dip Setting**

**Preset dip**

	Dip 1 - 2	Dip 3	Dip 4	Dip 5	Dip 6	Dip 7	Dip 8
↑	See Baud Rate Table	Bypass	TA bistable	RDS ON	REMOTE ON	Reserved	Reserved
↓	Vedi Tabella Baud Rate	Operate	TA monostable	RDS OFF	REMOTE OFF	Reserved	Reserved

	Dip 1	Dip 2
2400	↓	↓
4800	↑	↓
9600	↓	↑
19200	↑	↑

**Preset dip**