

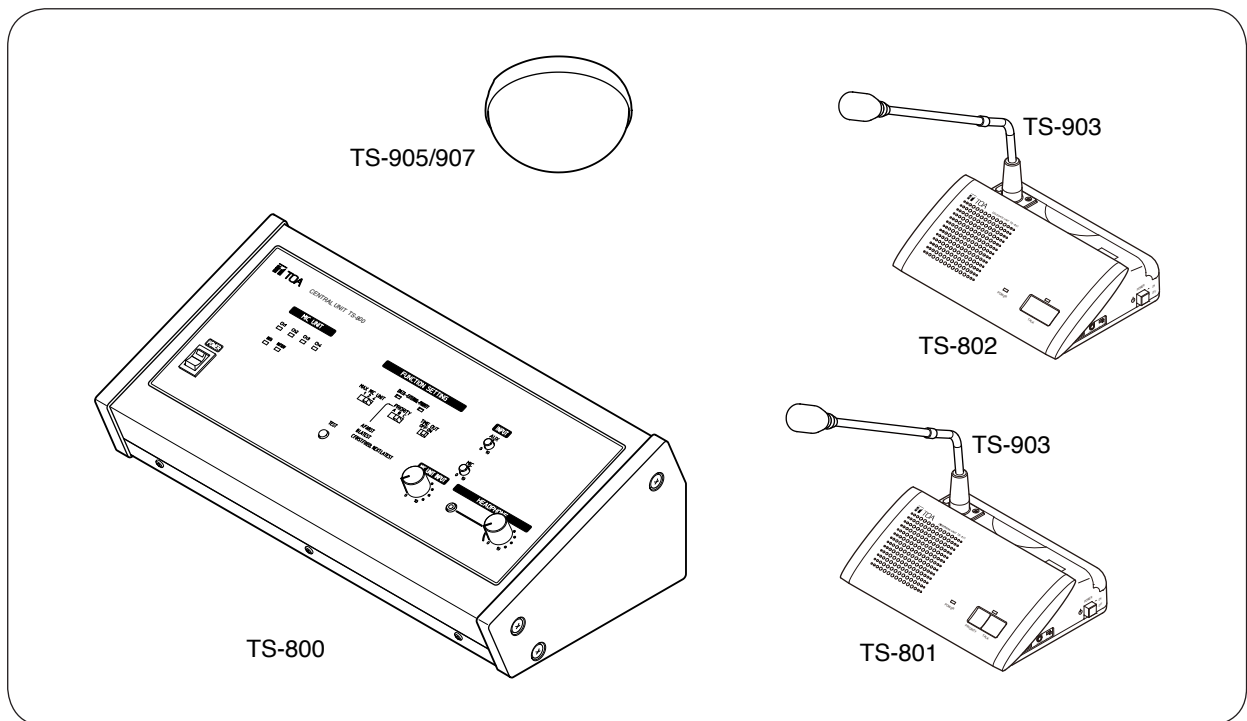

## OPERATING INSTRUCTIONS

# INFRARED CONFERENCE SYSTEM

## TS-800 series



Thank you for purchasing TOA's Infrared Conference System.  
Please carefully follow the instructions in this manual to ensure long, trouble-free use of your equipment.

# TABLE OF CONTENTS

<b>1. SAFETY PRECAUTIONS</b> .....	4
<b>2. GENERAL DESCRIPTION</b> .....	7
<b>3. FEATURES</b> .....	7
<b>4. SYSTEM EQUIPMENT CONFIGURATION</b> .....	8
<b>5. NOMENCLATURE AND FUNCTIONS</b> .....	9
5.1. Central Unit TS-800 .....	9
5.2. Chairman Unit TS-801 .....	12
5.3. Delegate Unit TS-802 .....	15
<b>6. OPERATION</b> .....	18
6.1. Initiating Speech .....	18
6.2. Initiating Priority Speech (TS-801 only) .....	19
6.2.1. When the Priority Speech key is set to PTT type (Factory-preset) .....	19
6.2.2. When the Priority Speech key is set to ALT type .....	20
<b>7. FUNCTION SETTINGS</b> .....	21
7.1. Setting the Maximum Number of Simultaneous Speakers .....	21
7.2. Speech Priority Settings .....	21
7.2.1. Mode A: first-in/first-out priority (factory-preset switch position) .....	21
7.2.2. Mode B: last-in/first-out priority .....	21
7.2.3. Mode C: priority fixed for first-enabled unit, and last-in/first-out priority for all subsequent units .....	22
7.3. Mic-Off Function .....	22
<b>8. SYSTEM CONNECTION EXAMPLES</b> .....	23
<b>9. INFRARED SERVICE AREAS</b> .....	24
9.1. Infrared Transmitter/Receiver .....	24
9.2. Chairman Unit and Delegate Unit .....	25
<b>10. INSTALLATION AND CONNECTIONS</b> .....	26
10.1. Notes on Installation of the Infrared Transmitter/Receiver Unit .....	26
10.2. Infrared Transmitter/Receiver Unit Arrangement Examples .....	27
10.3. Wiring between the Infrared Transmitter/Receiver Unit and the Central Unit ...	28
10.4. Mounting the Infrared Transmitter/Receiver Unit .....	30
10.4.1. Ceiling mounting .....	30
10.4.2. Mounting on a microphone stand .....	31
10.5. Connections between the Infrared Transmitter/Receiver Unit and the Central Unit .....	32
10.5.1. Connecting .....	32
10.5.2. Coaxial cable processing .....	33
10.6. Using Wired Microphones and Sound Source Equipment .....	38
10.6.1. Wired microphone use .....	38
10.6.2. Sound source equipment use .....	38
10.7. Recording the Conference Contents .....	39

<b>11. CHAIRMAN AND DELEGATE UNIT INSTALLATION AND SETTINGS</b> .....	40
<b>12. CHAIRMAN AND DELEGATE UNIT POWER SUPPLY</b> .....	41
12.1. BP-900 Lithium-Ion Battery .....	41
12.1.1. Inserting the lithium-ion battery .....	41
12.1.2. Recharging .....	42
12.2. AD-0910 AC Adapter .....	43
<b>13. CENTRAL UNIT RACK MOUNTING</b> .....	44
<b>14. INSTALLATION STATUS CONFIRMATION</b> .....	45
<b>15. APPENDIX</b> .....	46
15.1. Confirming the Wiring Design .....	46
15.1.1. Values necessary for calculating the loss .....	46
15.1.2. Values necessary for calculating the voltage drop .....	46
15.2. Computational Equation .....	47
15.2.1. Finding the wiring loss .....	47
15.2.2. Finding the wiring voltage drop .....	47
15.3. Design Examples .....	48
15.3.1. Example 1: When installing 4 TS-905 Infrared Transmitter/Receiver units using 4 coaxial cables reaching from the Central unit: .....	48
15.3.2. Example 2: When installing 4 TS-905 Infrared Transmitter/Receiver units using 1 coaxial cable reaching from the Central unit (one 4-branch distributor connected): .....	49
15.3.3. Example 3: When installing each 4 TS-905 Infrared Transmitter/Receiver units using 4 coaxial cables reaching from the Central unit (four 4-branch distributors connected): .....	51
15.3.4. Example 4: When installing 16 TS-905 Infrared Transmitter/Receiver units using 1 coaxial cable reaching from the Central unit (five 4-branch distributors connected): .....	52
<b>16. IF A FAILURE IS DETECTED</b> .....	54
16.1. Chairman Unit TS-801 and Delegate Unit TS-802 .....	54
16.2. Central Unit TS-800 .....	55
16.3. Battery Charger BC-900 .....	55
<b>17. SPECIFICATIONS</b> .....	56
17.1. Central Unit TS-800 .....	56
17.2. Chairman Unit TS-801, Delegate Unit TS-802 .....	57
17.3. Microphone (standard) TS-903, Microphone (long) TS-904 .....	57
17.4. Infrared Transmitter/Receiver TS-905, TS-907 .....	58
17.5. Lithium-Ion Battery BP-900 .....	58
17.6. Battery Charger BC-900 .....	59
17.7. AC Adapter AD-0910 .....	59
17.8. Distributor YW-1022 (2-branch distributor), YW-1024 (4-branch distributor) .....	60
17.9. Rack Mounting Bracket MB-TS900 .....	60

# 1. SAFETY PRECAUTIONS

- Before installation or use, be sure to carefully read all the instructions in this section for correct and safe operation.
- Be sure to follow all the precautionary instructions in this section, which contain important warnings and/or cautions regarding safety.
- After reading, keep this manual handy for future reference.

## Safety Symbol and Message Conventions

Safety symbols and messages described below are used in this manual to prevent bodily injury and property damage which could result from mishandling. Before operating your product, read this manual first and understand the safety symbols and messages so you are thoroughly aware of the potential safety hazards.



### **DANGER**

Indicates an imminently hazardous situation, which, if not avoided, will result in death or serious injury.

#### Applicable to Lithium-ion battery

- Should the following irregularity be found during use, immediately switch off the power, take the batteries out of the unit, and keep them away from fire. Failure to do so may cause a fire or explosion.
  - If you find battery leakage, discoloration, deformation or damage.
  - If you detect smoke or a strange smell coming out from the batteries.
- Do not deform, modify, nor solder the batteries. Doing so may damage the battery's safety or protector mechanism, causing the batteries to fire, leak, or explode.
- Never short the positive and negative terminals with a wire or other metallic objects. Also, avoid carrying or keeping the batteries with metallic objects such as necklaces or hair pins. Doing so may cause the batteries to fire, explode, leak, or heat.
- Never heat the batteries nor throw them into a fire. Doing so may damage the battery's gas relief valve or safety mechanism, causing the batteries to fire or explode.
- Do not dip the batteries into water nor wet the battery terminals. This may corrode the batteries, possibly causing them to fire, explode, leak, or heat.
- Note correct polarity (positive and negative orientation) when inserting the batteries into a battery charger. Doing otherwise may cause them to fire, explode, leak, or heat.
- Do not use, keep, nor leave the batteries near fire or in locations where the temperature rises above 60°C such as in a sun-heated car. Doing so may damage the battery's safety or protector mechanism, causing the batteries to fire, explode, leak, or heat.
- Be sure to use the BC-900 charger when recharging the batteries. Using other battery charger may cause them to fire, explode, leak, or heat.
- Use the batteries only with the equipment specified. Failure to do so may cause the batteries to fire, explode, leak, or heat.
- Do not drop the batteries nor give them a shock. Doing so may damage the battery's safety or protector mechanism, causing the batteries to fire, explode, leak, or heat.
- There is a fear of losing one's eyesight if a battery leakage gets in one's eyes. Wash it away with clean water and consult a doctor immediately. If a battery leakage stains one's skin or clothes, wash it away with clean water as there is a fear of impairing the skin.



### **WARNING**

Indicates a potentially hazardous situation which, if mishandled, could result in death or serious personal injury.

## When Installing the Unit

#### Applicable to Central unit, Chairman unit, Delegate unit, Battery charger, and AC adapter

- Do not expose the unit to rain or an environment where it may be splashed by water or other liquids, as doing so may result in fire or electric shock.

- Use the unit only with the voltage specified on the unit. Using a voltage higher than that which is specified may result in fire or electric shock.
- Do not cut, kink, otherwise damage nor modify the power supply cord. In addition, avoid using the power cord in close proximity to heaters, and never place heavy objects -- including the unit itself -- on the power cord, as doing so may result in fire or electric shock.
- Avoid installing or mounting the unit in unstable locations, such as on a rickety table or a slanted surface. Doing so may result in the unit falling down and causing personal injury and/or property damage.

## When the Unit is in Use

### Applicable to Central unit, Chairman unit, Delegate unit, Battery charger, and AC adapter

- Should the following irregularity be found during use, immediately switch off the power, disconnect the power supply plug from the AC outlet and contact your nearest TOA dealer. Make no further attempt to operate the unit in this condition as this may cause fire or electric shock.
  - If you detect smoke or a strange smell coming from the unit.
  - If water or any metallic object gets into the unit
  - If the unit falls, or the unit case breaks
  - If the power supply cord is damaged (exposure of the core, disconnection, etc.)
  - If it is malfunctioning (no tone sounds.)
- To prevent a fire or electric shock, never open nor remove the unit case as there are high voltage components inside the unit. Refer all servicing to your nearest TOA dealer.
- Do not place cups, bowls, or other containers of liquid or metallic objects on top of the unit. If they accidentally spill into the unit, this may cause a fire or electric shock.
- Do not insert nor drop metallic objects or flammable materials inside the unit, as this may result in fire or electric shock.
- Do not touch a plug during thunder and lightning, as this may result in electric shock.

### Applicable to Battery charger and Lithium-ion battery

- Stop charging if the batteries are not fully charged within 5 hours. Continuously charging over 5 hours may cause the batteries to fire, explode, leak, or heat.

### Applicable to Central unit, Chairman unit, and Delegate unit



- To prevent possible hearing damage, do not listen at high volume levels for long periods.



## CAUTION

Indicates a potentially hazardous situation which, if mishandled, could result in moderate or minor personal injury, and/or property damage.

## When Installing the Unit

- These servicing instructions are for use by qualified personnel only. To reduce the risk of electric shock, do not perform any servicing other than that contained in the operating instructions unless you are qualified to do so. Refer all servicing to qualified service personnel.

### Applicable to Central unit

- Be sure to follow the instructions below when rack-mounting the unit. Failure to do so may cause a fire or personal injury.
  - Install the equipment rack on a stable, hard floor. Fix it with anchor bolts or take other arrangements to prevent it from falling down.
  - To rack-mount the unit, use the supplied rack mounting hardware.
  - When connecting the unit's power cord to an AC outlet, use the AC outlet with current capacity allowable to the unit.

**Applicable to Central unit, Chairman unit, Delegate unit, Battery charger, and AC adapter**

- Never plug in nor remove the power supply plug with wet hands, as doing so may cause electric shock.
- When unplugging the power supply cord, be sure to grasp the power supply plug; never pull on the cord itself. Operating the unit with a damaged power supply cord may cause a fire or electric shock.
- When moving the unit, be sure to remove its power supply cord from the wall outlet. Moving the unit with the power cord connected to the outlet may cause damage to the power cord, resulting in fire or electric shock. When removing the power cord, be sure to hold its plug to pull.
- Do not block the ventilation slots on the unit. Doing so may cause heat to build up inside the unit and result in fire.
- Avoid installing the unit in humid or dusty locations, in locations exposed to the direct sunlight, near the heaters, or in locations generating sooty smoke or steam as doing otherwise may result in fire or electric shock.

**When the Unit is in Use**

**Applicable to Central unit, Chairman unit, Delegate unit, Battery charger, and AC adapter**

- Do not place heavy objects on the unit as this may cause it to fall or break which may result in personal injury and/or property damage. In addition, the object itself may fall off and cause injury and/or damage.
- If dust accumulates on the power supply plug or in the wall AC outlet, a fire may result. Clean it periodically. In addition, insert the plug in the wall outlet securely.
- Switch off the power, and unplug the power supply plug from the AC outlet for safety purposes when cleaning or leaving the unit unused for 10 days or more. Doing otherwise may cause a fire or electric shock.

**Applicable to Central unit, Chairman unit, Delegate unit, and Battery charger**

- Use the dedicated AC adapter for the unit. Note that the use of other adapter may cause a fire.

**Applicable to Central unit**

- Make sure that the volume control is set to minimum position before power is switched on. Loud noise produced at high volume when power is switched on can impair hearing.

**Applicable to Chairman unit and Delegate unit**

- Make sure that the volume control is set to minimum position before power is switched on. Loud noise produced at high volume when power is switched on can impair hearing.
- When the unit is not in use for 10 days or more, be sure to take the battery out of the unit because battery leakage may cause a fire, personal injury, or contamination of environment.
- Replace the battery only with the TOA BP-900. Using a battery other than designated may cause it to explode. When you discard batteries, please contact the local dealer from whom you bought.

**Applicable to Battery charger**

- Remove the power supply plug of charger from the AC outlet after charging completion, as doing otherwise may cause a fire.

**Applicable to Lithium-ion battery**

- When you discard batteries, please contact the local dealer from whom you bought.

**Applicable to Central unit, Chairman unit, Delegate unit, and Battery charger**

This is a class A product.

In a domestic environment this product may cause radio interference in which case the user may be required to take adequate measures.

## 2. GENERAL DESCRIPTION

The TOA TS-800 Series is a cordless infrared conference system that can be installed and removed quickly and easily. Since the TS-801 Chairman unit and the TS-802 Delegate unit require no wiring, they permit easy installation based on a free layout. The Infrared Transmitter/Receiver unit and recording equipment are connected to the TS-800 Central unit, and the system function settings and status indications are performed at the Central unit.

## 3. FEATURES

- Since the system is cordless, it can be easily installed and removed, permitting flexible relocation and changes in system layout.
- The system's infrared communication method is not only resistant to radio interference and eavesdropping, but it also permits simultaneous use of systems in adjacent conference rooms with no crosstalk.
- The number of Chairman and Delegate units can be varied as required depending on the number of participants. Up to 64 Chairman and Delegate units can be used per system.
- The maximum number of Infrared Transmitter/Receiver units to be installed in a system is 16 when they are all TS-905 units and 12 when they are all TS-907 units. (Also 12 when both models are mixed.)
- A function to restrict the number of speakers minimizes disorder that could result from simultaneous communications by meeting participants.
- The speech system selection function permits operation when the unit's Talk key is pressed to be set to first-in-first-out, last-in-first-out, or other priority.
- The Mic-Off function automatically turns off the unit's microphone after 30 seconds, even if a user forgets to turn off the microphone after speech completion.
- While the Chairman or Delegate unit is in use, its built-in monitor speaker is turned off, preventing acoustic feedback\*.
- The Central unit can be used in conjunction with wired microphones and output source equipment, depending on application.
- Since the Central unit can be connected to recording equipment, it is ideal for use in preparing conference minutes.
- The Chairman unit features a priority speech key which allows it to take precedence over Delegate units when speaking.
- The dedicated microphone used by Chairman and Delegate units employs an XLR connector that not only permits easy attachment and detachment of the microphone, but also saves space when stored.
- Both Chairman and Delegate units can be operated on both their built-in rechargeable lithium-ion batteries or AC power supply.
- Two types of dedicated microphones are made available for the Chairman and Delegate units: "standard" and "long."

\* Acoustic feedback: A squeal or howl from the speaker caused by an audio loop condition in which part of the speaker output is picked up by the same microphone, and subsequently amplified and output from the speaker again, quickly building in intensity.

# 4. SYSTEM EQUIPMENT CONFIGURATION

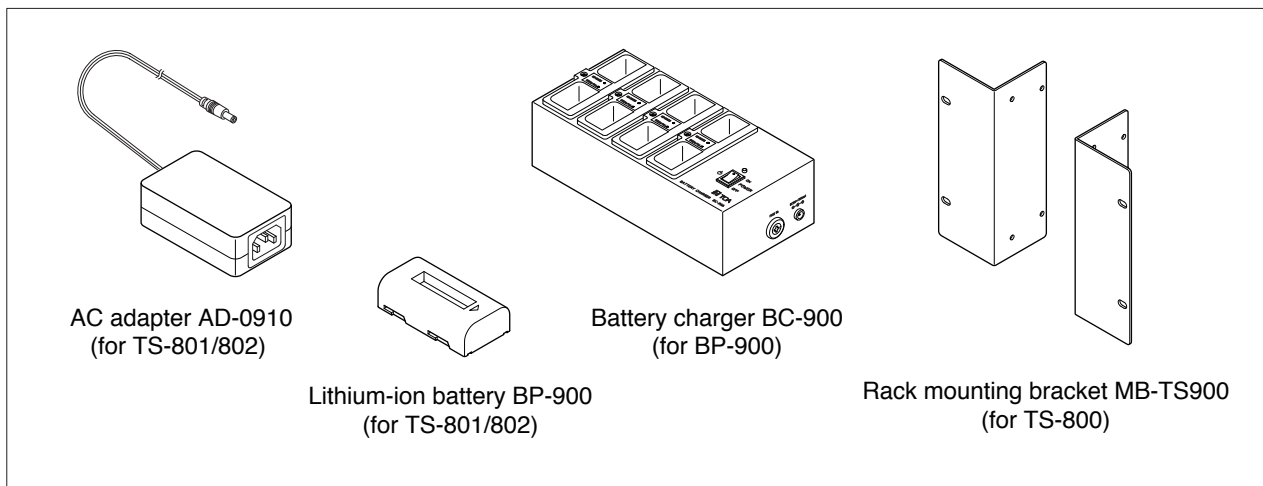
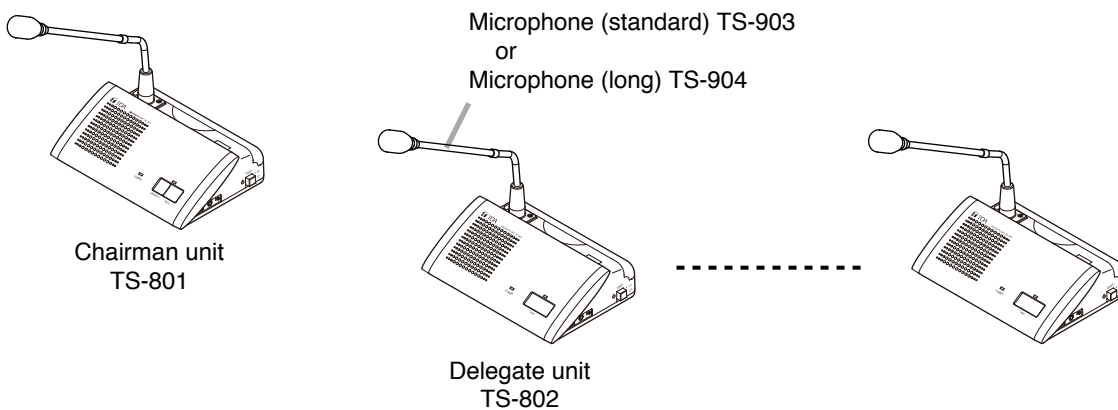
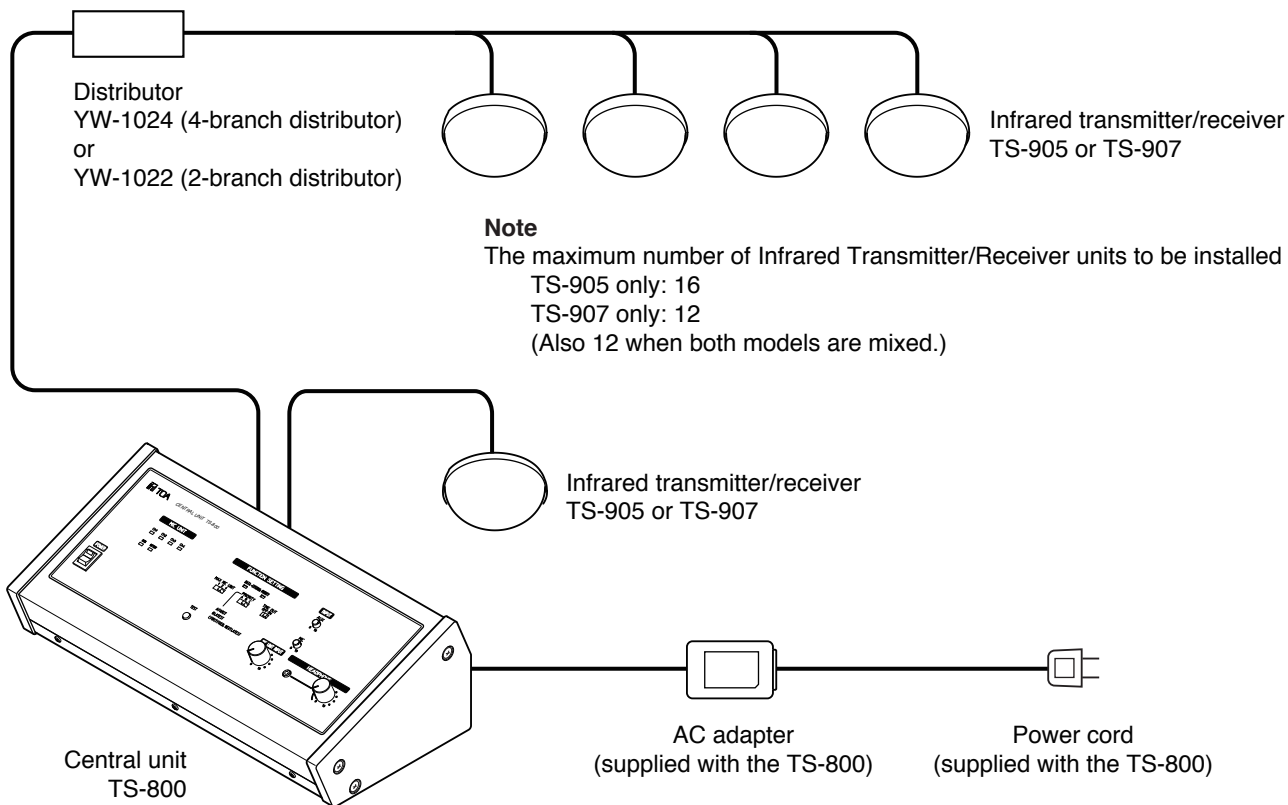



## 5. NOMENCLATURE AND FUNCTIONS

### 5.1. Central Unit TS-800

[Top]

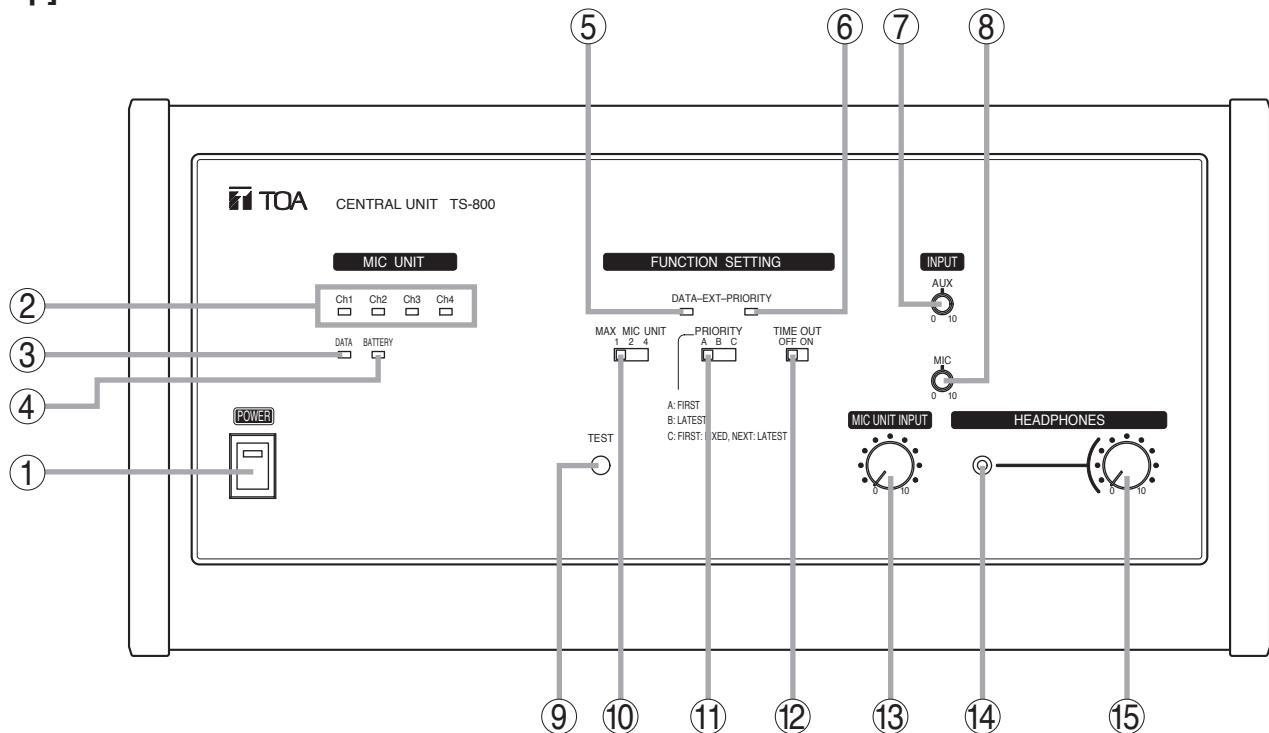

#### 1. Power switch

Setting this switch to the ON position causes the Power indicator to light.

#### 2. Audio signal receiving indicators [Ch1/Ch2/Ch3/Ch4]

Light up when audio signals are received from either Chairman or Delegate units. Audio signals are transmitted or received through 4 channels. The number of channels to be used can be set with the Simultaneous Speaker No. Setting switch (10). These indicators light in the same number as that of the Chairman or Delegate units currently being used for speech. (Which indicator will light is not specified.)

#### 3. Data signal receiving indicator

Lights when control data is received from the Chairman or Delegate unit.

#### 4. Battery indicator

Flashes when the lithium-ion battery of the Chairman or Delegate unit nears complete discharge. (In this event, the Microphone In-Use indicator and the Speech indicator on the corresponding unit also flash.)

#### Note

Be sure to replace the lithium-ion battery of the corresponding unit immediately if this indicator begins to flash.

#### 5. External control communication indicator

Remains lit during communications with a computer (PC) or operation panel connected to the RS-232C terminal.

#### 6. External control priority indicator

Either lights or flashes when a PC or operation panel connected to the RS-232C terminal performs priority operation. In this event, three function setting switches (10), (11), and (12) cannot be used.

#### 7. AUX input volume control

Adjusts the input signal level of the AUX Input Terminal (17) located on the rear panel.

#### 8. MIC input volume control

Adjusts the input level of the MIC Input Terminal (18) on the rear panel.

#### 9. Installation check button

Installation status for the Infrared Transmitter/Receiver, Chairman unit, and Delegate unit can be checked. (Refer to p. 45.)

**10. Simultaneous speaker No. setting switch**

Used to set the number of Chairman and Delegate units that can be simultaneously operated. The indications [1], [2], and [4] represent the number of simultaneously operable units. (Refer to p. 21.)

**Note**

This switch is factory-preset to the [1] position.

**11. Speech priority selector switch**

Determines the priority mode when the Talk key of the Chairman or Delegate unit is pressed. (Refer to p. 21.)

A: First-in-first-out priority

B: Last-in-first-out priority

C: Priority fixed for the first unit, and last-in-first-out priority for all other subsequent units.

**Note**

This switch is factory-preset to the [A] position.

**12. Mic-off setting switch**

Automatically turns off Chairman or Delegate unit microphones 30 seconds after speech is completed if the user should neglect to turn off the microphone. (Refer to p. 22.)

**Note**

This switch is factory-preset to the OFF position.

**13. Speech volume control**

Adjusts the microphone volume of the Chairman unit and Delegate unit.

**14. Headphone jack (Mini-jack)**

Connects to headphones.

**15. Headphone volume control**

Adjusts the sound volume of the headphones.

**[Bottom]**

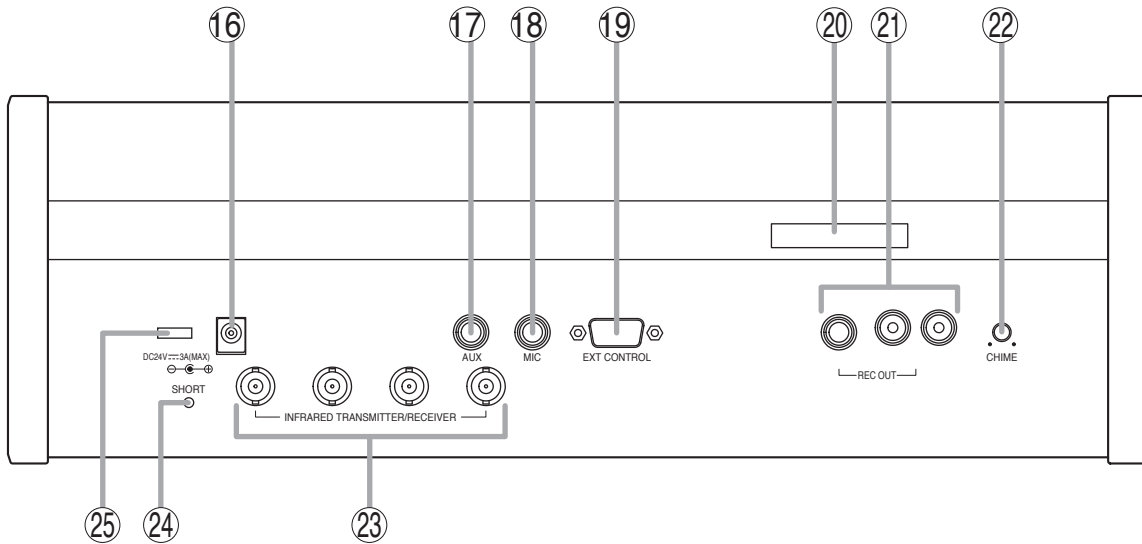

**16. DC input**

Connect the supplied AC adapter to this terminal.

**17. AUX input terminal**

Connect a CD player, tape recorder, or other similar equipment to this terminal.

**18. MIC input terminal**

Connect a wired microphone to this terminal.

**19. External control terminal**

Connect this terminal to the serial port of a PC, operation panel, or other external control equipment.

**20. Marking plate**

Shows the Manufacturer's Name, Model Name, and Electrical Rating.

**21. Recording output terminal**

Connect an Alternate Recording Deck or MD recorder. An amplifier can also be connected for public address applications.

**22. Priority chime volume control**

Adjusts the output volume of the chime tone that sounds when the Priority Speech key on the Chairman unit is pressed.

**23. Infrared transmitter/receiver unit I/O terminals**

Connect the Infrared Transmitter/Receiver unit or distributor to this terminal. By using the YW-1022 (2-branch distributor) and/or YW-1024 (4-branch distributor), the following maximum number of Infrared Transmitter/Receiver units can be connected: 16 units when they are all TS-905 units, 12 units when they are all TS-907 units. (Also 12 units when both models are mixed.)

**24. Short circuit indicator**

Lights when the Infrared Transmitter/Receiver unit or its connected cable is shorted.

**25. Cable clip**

Run the AC adapter cable through this clip to prevent its plug from being removed from the DC input.

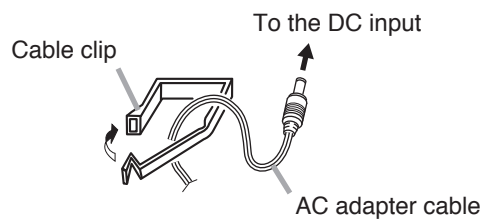

## 5.2. Chairman Unit TS-801

[Top]

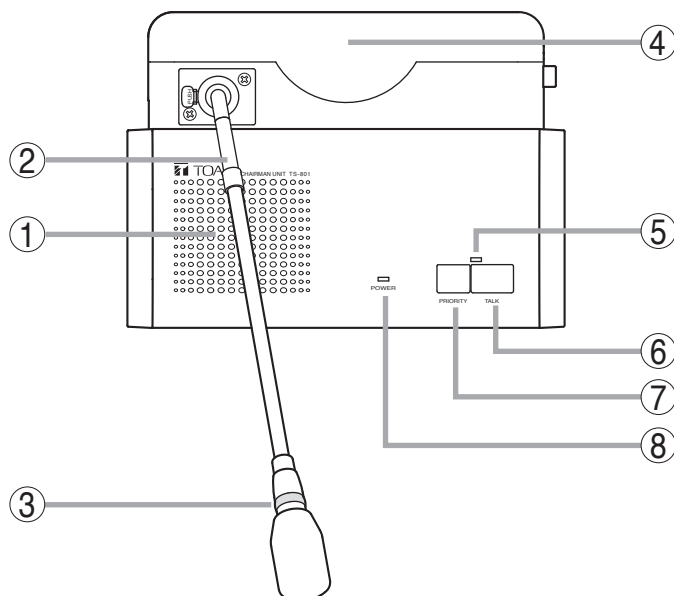

### Note

No microphone is supplied with the TS-801 Chairman unit.

### 1. Monitor speaker

Speech input from other Chairman or Delegate units and the Central unit is output from this speaker.

Use the right-side Monitor Volume Control (14) to adjust the volume. No sound is output from the speaker of the unit in use while speaking.

### 2. Microphone

Use either the TS-903 (Standard) or TS-904 (Long) dedicated microphone.

### 3. Microphone in-use indicator

Lights when the microphone is turned on (for speech) and flashes when the battery level is low.

### 4. Infrared emitter/detector

The device used to transmit and receive infrared communication signals is built inside this panel.

#### Note

Never place any object that could block infrared signal access to this part of the unit, as this would prevent the unit from transmitting or receiving its required infrared signal.

### 5. Speech indicator

Remains lit while the microphone is in use (during speech). The indicator flashes when the unit is out of the communications service area.

### 6. Talk key

When this key is pressed, both the Microphone In-Use indicator (3) and the Speech indicator (5) light, and the microphone turns on. Pressing this key again turns off both indicators and the microphone.

### 7. Priority speech key

Gives speaking priority to the current speaker. When this key is used for speech, no other delegate units can be used. Also, only the current speech made with the Priority speech key is output at the Central Unit's recording and line outputs.

The key has 2 different operating modes, PTT and ALT, which can be selected with the Priority speech key operation setting switch (12).

- When PTT mode is selected, the microphone only turns on while the key is pressed, during which time the Speech (5) and Microphone in-use (3) indicators remain lit.
- When ALT mode is selected, pressing the key turns on the microphone and causes the Speech (5) and Microphone in-use (3) indicators to light. Pressing the key again turns off the microphone and these indicators.

If Chime is set to sound, a chime tone sounds when the key is pressed. For the chime setting, use the Priority chime mute switch (11).

### 8. Power indicator

Lights when the power is switched ON.

This indicator also flashes when the battery level is low or the unit is outside the communications service area.

## [Bottom]

Remove the cover on the bottom side of the unit to expose its setting switches.

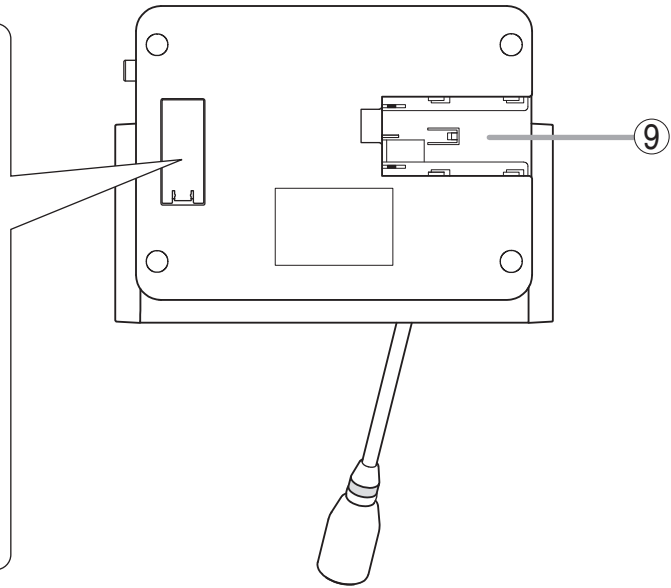
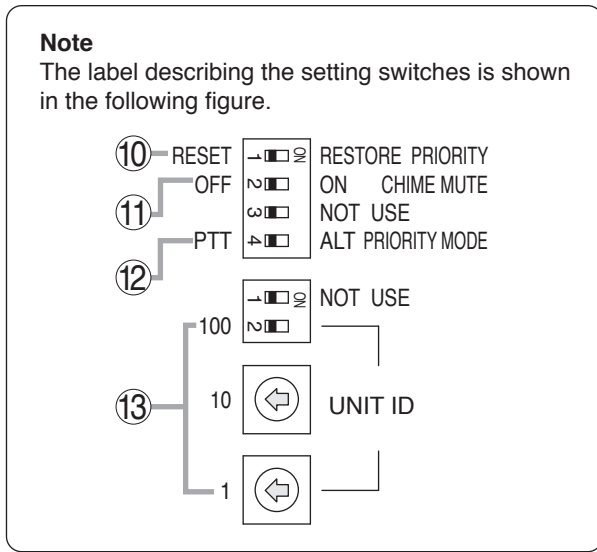

### 9. Lithium-ion battery compartment

Install only a dedicated BP-900 Lithium-Ion Battery in this compartment.

### 10. Priority operation setting switch

Following completion of a priority speech, this switch is used to reset the operating status of Chairman and Delegate units whose operations were interrupted by the depression of a Priority Speech key (7).

Set the switch to RESTORE in order to resume the mode in operation prior to initiation of the priority speech, and to RESET when resumption is not desired.

#### Note

This switch is factory-preset to the RESET position.

### 11. Priority chime mute switch

Disables the chime that sounds when the Priority Speech key is pressed.

Set this switch to OFF when sound output is desired, and to ON when no sound is desired.

#### Note

This switch is factory-preset to the OFF position.

### 12. Priority speech key operation setting switch

Use to set the Priority speech key operation mode.

PTT: Speech only possible while the Priority speech key is being pressed.

ALT: Speech enabled when the Priority speech key is pressed, and disabled when the key is pressed again.

#### Note

The switch is factory-preset to PTT.

### 13. Unit address number setting switch

Set the unit address number ([001] – [064]), taking care to ensure that the same number is not duplicated in the system.

If the number [000] is assigned to a unit, the user of that unit cannot speak. However, the unit can be used for monitoring.

Set a numeral for the ones place and tens place. Set this switch to OFF to set the hundreds place to "0" and to ON to set it to "1." Be sure to leave this switch in the OFF position.

#### Note

This number is factory-preset to [000].

## [Right side]

### 14. Monitor volume control

Adjusts the output volume of the monitor speaker and right-side headphone output.

### 15. Headphone jack

Connect headphones to this jack (mini-jack). Connecting the headphones cuts off the output from the monitor speaker.

#### Note

A headphone jack is located on both the left and right side panels.

### 16. Power switch

Press this switch to switch on the power. To switch off the power, press this switch again.

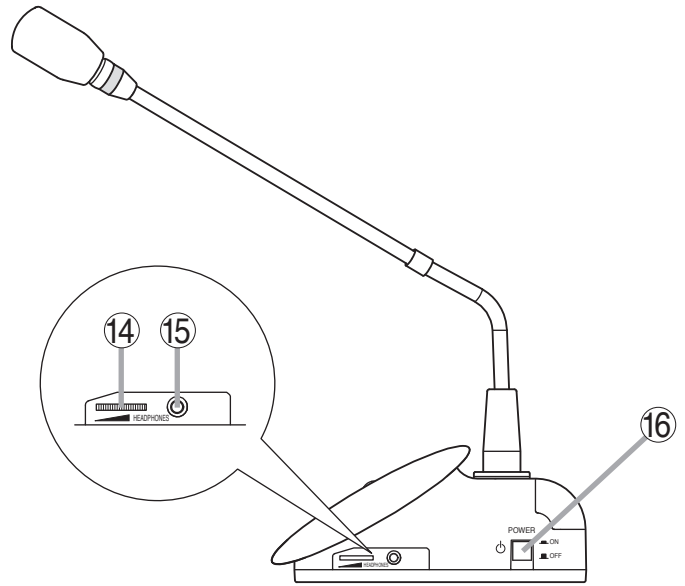

## [Left side]

### 17. DC inlet

Connect the dedicated AD-0910 AC Adapter to this terminal.

### 18. Headphone volume control

Adjusts the output volume of the left-side headphone output.

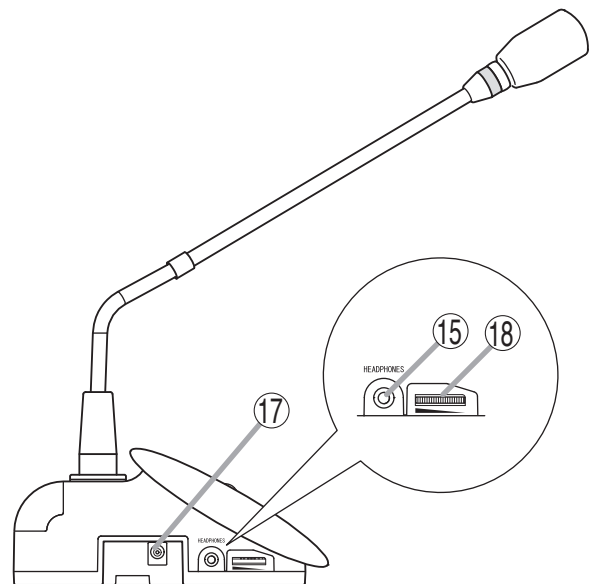

### 5.3. Delegate Unit TS-802

[Top]

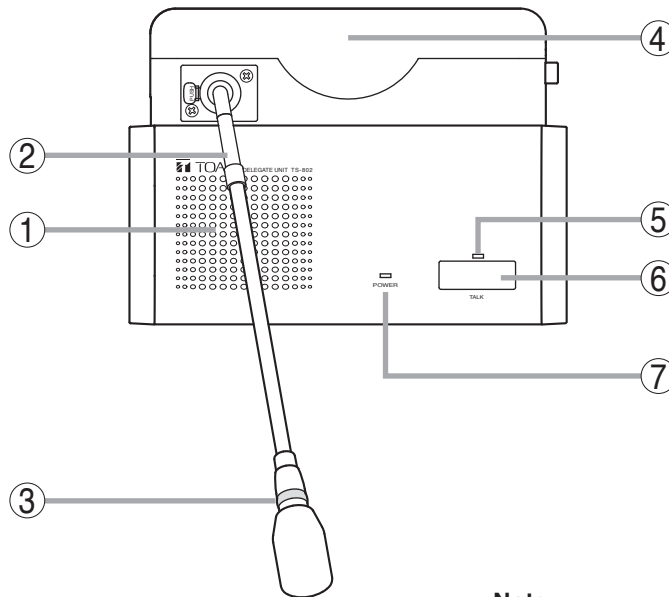

#### Note

No microphone is supplied with the TS-802 Delegate unit.

#### 1. Monitor speaker

Speech input from other Chairman or Delegate units and the Central unit is output from this speaker.

Use the right-side Monitor Volume Control (10) to adjust the volume. No sound is output from the speaker of the unit in use while speaking.

#### 2. Microphone

Use either the TS-903 (Standard) or TS-904 (Long) dedicated microphone.

#### 3. Microphone in-use indicator

Lights when the microphone is turned on (for speech) and flashes when the battery level is low.

#### 4. Infrared emitter/detector

The device used to transmit and receive infrared communication signals is built inside this panel.

#### Note

Never place any object that could block infrared signal access to this part of the unit, as this would prevent the unit from transmitting or receiving its required infrared signal.

#### 5. Speech indicator

Remains lit while the microphone is in use (during speech). The indicator flashes when the unit is out of the communications service area.

#### 6. Talk key

When this key is pressed, both the Microphone In-Use indicator (3) and the Speech indicator (5) light, and the microphone turns on. Pressing this key again turns off both indicators and the microphone.

#### 7. Power indicator

Lights when the power is switched ON.

This indicator also flashes when the battery level is low or the unit is outside the communications service area.

## [Bottom]

Remove the cover on the bottom side of the unit to expose its setting switches.

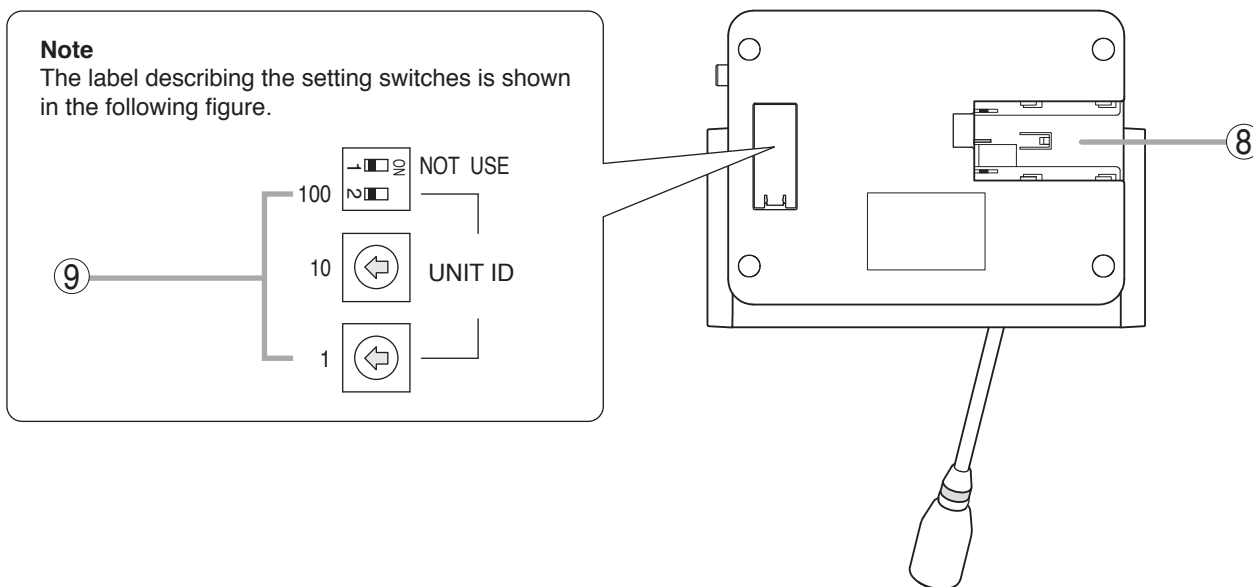

### 8. Lithium-ion battery compartment

Install only a dedicated BP-900 Lithium-Ion Battery in this compartment.

### 9. Unit address number setting switch

Set the unit address number ([001] – [064]), taking care to ensure that the same number is not duplicated in the system.

If the number [000] is assigned to a unit, the user of that unit cannot speak. However, the unit can be used for monitoring.

Set a numeral for the ones place and tens place. Set this switch to OFF to set the hundreds place to "0" and to ON to set it to "1." Be sure to leave this switch in the OFF position.

**Note**

This number is factory-preset to [000].



## [Right side]

### 10. Monitor volume control

Adjusts the output volume of the monitor speaker and right-side headphone output.

### 11. Headphone jack

Connect headphones to this jack (mini-jack). Connecting the headphones cuts off the output from the monitor speaker.

#### Note

A headphone jack is located on both the left and right side panels.

### 12. Power switch

Press this switch to switch on the power. To switch off the power, press this switch again.

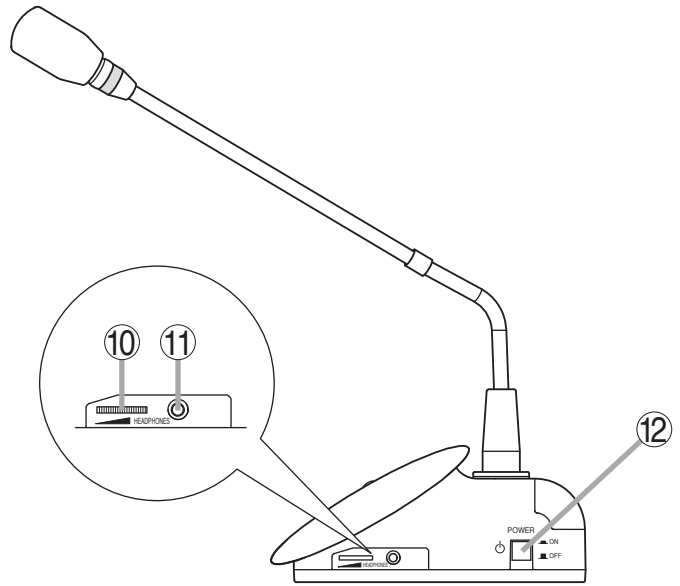

## [Left side]

### 13. DC inlet

Connect the dedicated AD-0910 AC Adapter to this terminal.

### 14. Headphone volume control

Adjusts the output volume of the left-side headphone output.

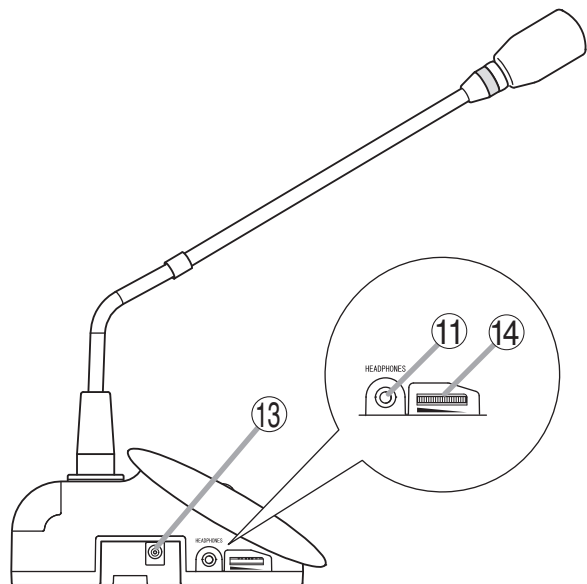

## 6. OPERATION

### 6.1. Initiating Speech

**Step 1.** Press the Talk key on the Chairman or Delegate unit.

The Speech indicator and Microphone In-Use indicator light, placing the unit in speech mode.

No sound is output from the monitor speaker while both indicators are continuously lit.

**Note**

The unit cannot be used for speech if the indicators do not light.

**Step 2.** Speak into the microphone.

**Step 3.** Press the Speech key again after speech completion.

The indicators go out, and sound can be output from the monitor speaker.

**Note**

When the user forgets to turn off the microphone, the Mic-Off function automatically turns off the microphone approximately 30 seconds after speech completion. (Refer to p. 22.)

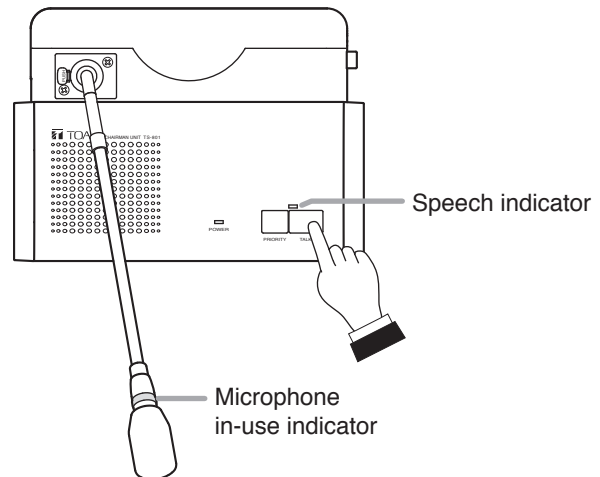

The figure shows the TS-801.

## 6.2. Initiating Priority Speech (TS-801 only)

The Chairman unit features the function that allows its speech to take precedence over that of the Delegate unit. The Chairman unit's speech is prior to the AUX and MIC inputs. The priority speech method can be determined by the Priority speech key operation setting switch built in the Chairman unit's bottom.

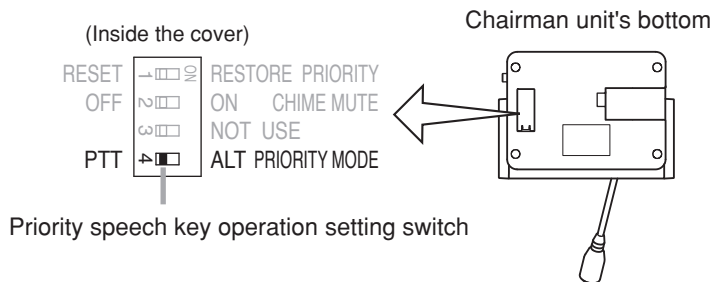

### 6.2.1. When the Priority Speech key is set to PTT type (Factory-preset)

**Step 1.** Speak while holding down the Priority Speech key. Both the Speech indicator and the Microphone In-Use indicator light, placing the unit in priority speech mode. No sound is output from the monitor speaker while both indicators are continuously lit. A chime tone\* sounds at other units, preventing them from being used for speaking.

\* The chime tone can be enabled or disabled using the Priority Chime Disable switch located on the underside of the unit.

ON: No chime sounds.

OFF: Chime sounds. (Factory-preset position)

#### Note

When two or more Chairman units are used in a system, a priority speech currently in progress from one unit can be interrupted by pressing the Priority Speech key of another Chairman unit, allowing the latter unit to go through. (Last-in-first-out priority)

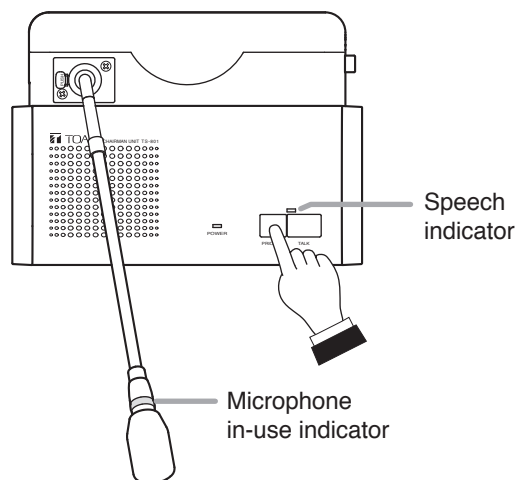

**Step 2.** Release the Priority Speech key after speech completion.

Both indicators go out, and sound can be output from the monitor speaker.

#### Note

After the priority speech is completed, the other interrupted unit resumes operation as predetermined by the setting of the Priority Operation Setting switch located on the bottom side of the unit.

**RESTORE:** Resumes the unit's mode prior to being interrupted by the priority speech.

**RESET:** Resets all units currently being used for speech (Factory-preset position). When an interrupted party wishes to continue to speak, the Speech key must again be pressed.

#### Note

The Chairman unit that initiated the priority speech automatically returns to its original mode following priority speech completion, regardless of its Priority Operation Setting switch setting.

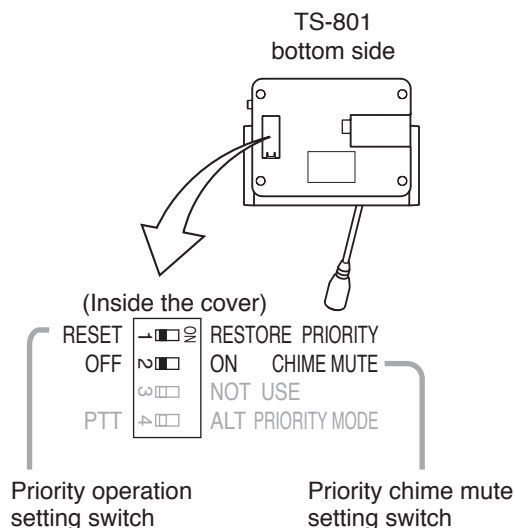

### 6.2.2. When the Priority Speech key is set to ALT type

**Step 1.** Press the Priority Speech key.

Both the Speech indicator and the Microphone In-Use indicator light, placing the unit in priority speech mode. No sound is output from the monitor speaker while both indicators are continuously lit. A chime tone\* sounds at other units, preventing them from being used for speaking.

\* The chime tone can be enabled or disabled using the Priority Chime Mute switch located on the bottom side of the unit.

- ON: No chime sounds.
- OFF: Chime sounds. (Factory-preset position)

**Note**

When two or more Chairman units are used in a system, a priority speech currently in progress from one unit can be interrupted by pressing the Priority Speech key of another Chairman unit, allowing the latter unit to go through. (Last-in-first-out priority)

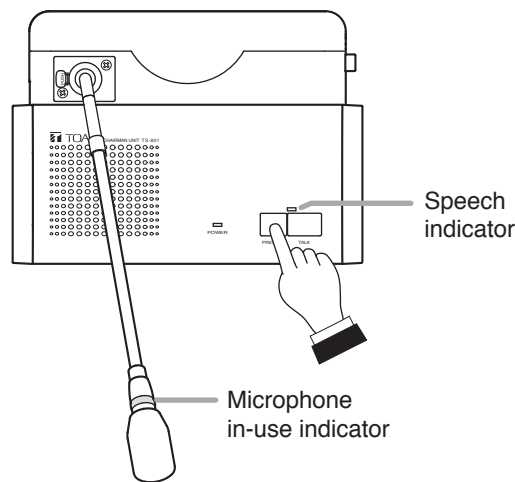

**Step 2.** Speak into the microphone.

**Step 3.** Press the Priority Speech key again after speech completion.

Both indicators go out, and sound can be output from the monitor speaker.

**Note**

After the priority speech is completed, the other interrupted unit resumes operation as predetermined by the setting of the Interrupted Priority Operation Setting switch located on the bottom side of the unit.

**RESTORE:** Resumes the unit's mode prior to being interrupted by the priority speech.

**RESET:** Resets all units currently being used for speech (Factory-preset position). When an interrupted party wishes to continue to speak, the Speech key must again be pressed.

**Note**

The Chairman unit that initiated the priority speech automatically returns to its original mode following priority speech completion, regardless of its priority Operation Setting switch setting.

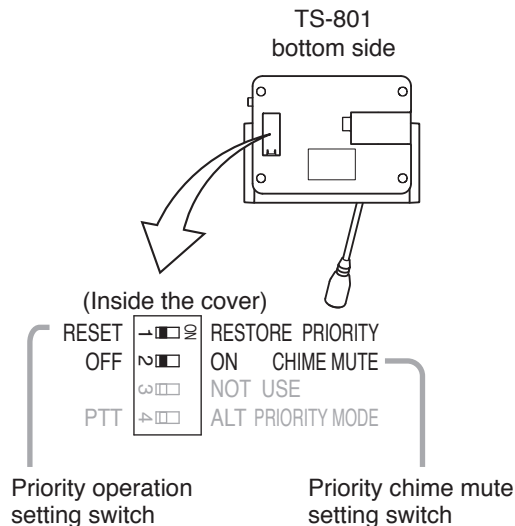

## 7. FUNCTION SETTINGS

### 7.1. Setting the Maximum Number of Simultaneous Speakers

Using the Simultaneous Speaker No. Setting switch on the TS-800 Central Unit, set the maximum total number of Chairman and Delegate units that can simultaneously initiate speech.

Set the switch to [1], [2], or [4] depending on the type of the conference. These numbers indicate the number of units that can simultaneously initiate speech. (This switch is factory-preset to the [1] position.)

#### Note

When the Talk key is pressed at a unit exceeding the set maximum number, the corresponding unit can only initiate speech as determined in the speech priority settings referred to in the next section.

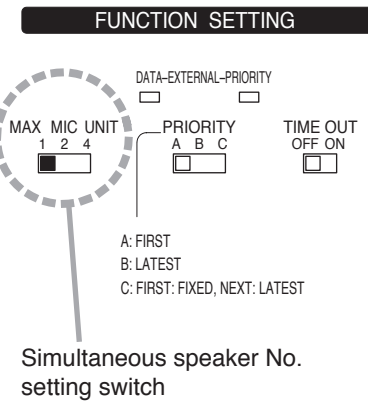

### 7.2. Speech Priority Settings

Operation following the depression of the Talk key on a Chairman or Delegate unit, when the maximum number of speakers that can be simultaneously initiated is reached, can be selected with the Speech Priority Selector switch on the TS-800 Central unit.

#### 7.2.1. Mode A: first-in/first-out priority (factory-preset switch position)

Speech is initiated on a first-come/first-served basis. When the maximum number of speakers is reached, subsequent speech requests cannot be accepted, even if the Talk key is pressed.

- Example showing the number of simultaneous speakers set to [2].

Chairman or Delegate unit

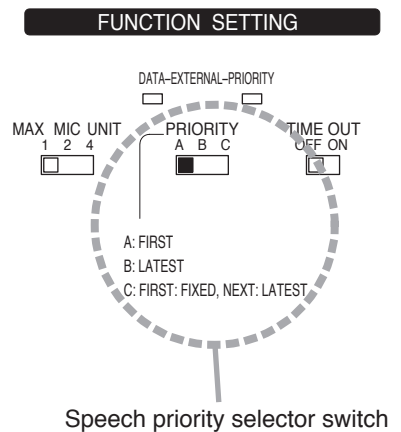
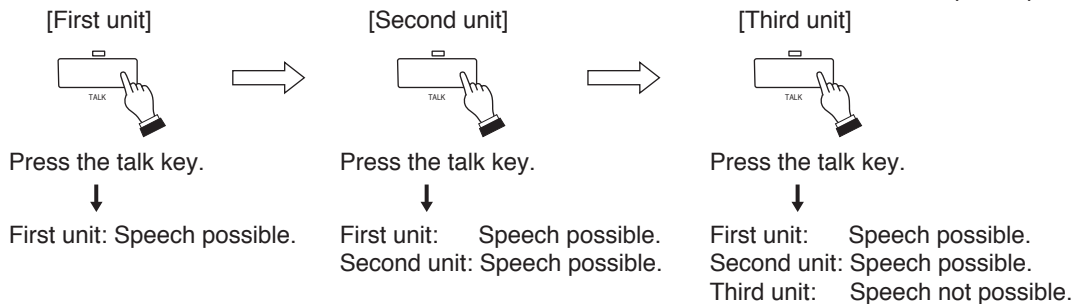

#### 7.2.2. Mode B: last-in/first-out priority

When the maximum number of simultaneous speakers is reached, input from the most recent subsequent Talk key-enabled Chairman or Delegate unit takes precedence, thus rendering earlier enabled units inoperable.

- Example showing the number of simultaneous speakers set to [2].

Chairman or Delegate unit

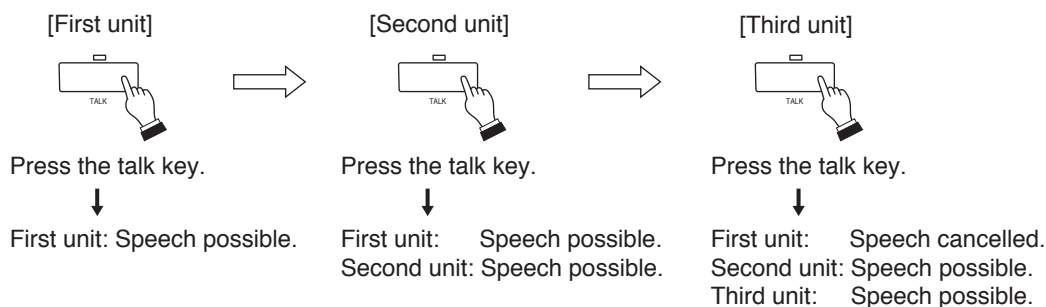

### 7.2.3. Mode C: priority fixed for first-enabled unit, and last-in/first-out priority for all subsequent units

The first-enabled Chairman or Delegate unit is given fixed speech priority until its Talk key is pressed again. All subsequent Talk key-enabled units are given last-in/first-out priority, as in Mode B.

- Example showing the number of simultaneous speakers set to [2].

Chairman or Delegate unit

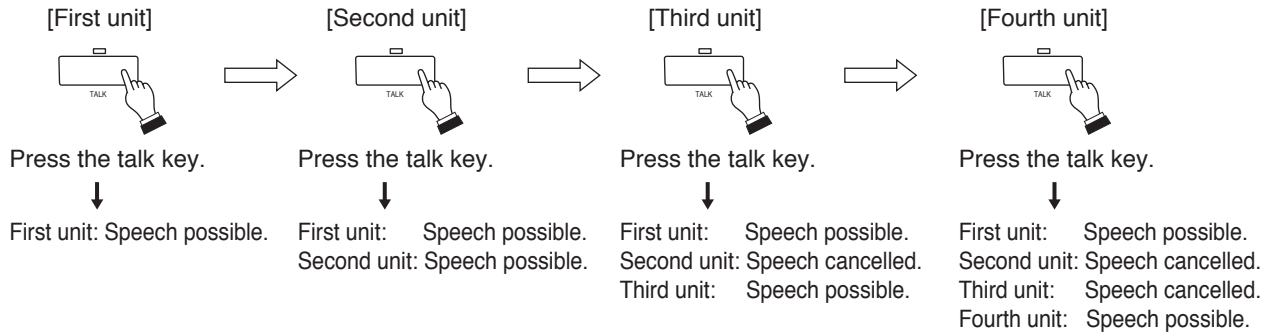

### 7.3. Mic-Off Function

This function automatically turns off the microphone if the user neglects to turn it off following speech completion.

This function is enabled when the Mic-Off Setting switch on the TS-800 Central Unit is set to the ON position.

The microphone automatically turns off if a duration of silence lasts for about 30 seconds.

It is recommended that the Mic-Off switch be set to the OFF position when not specifically using this function. (The Mic-Off switch is factory-preset to the OFF position.)

#### Notes

- When the Mic-Off switch is set to the ON position, the microphone automatically turns off if there is a silent interval of about 30 seconds, even though a speech may be in progress. In conferences, where long pauses during speeches can be experienced, set the switch to the OFF position.
- The Mic-Off function may not be operated correctly in high-noise areas.

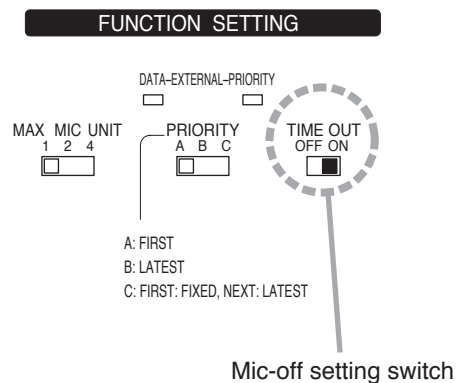

## 8. SYSTEM CONNECTION EXAMPLES

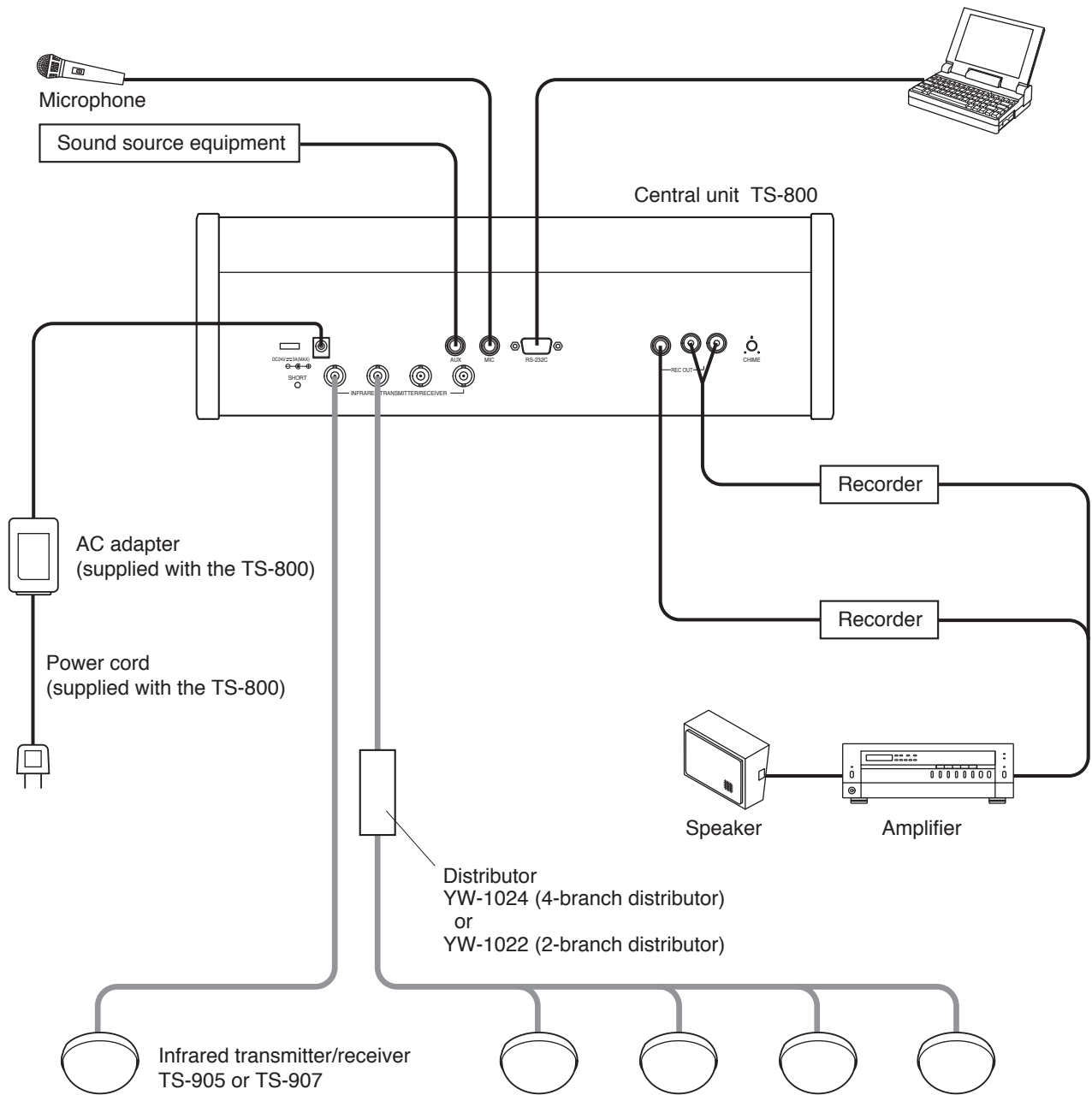

For details of the installation and connection of the Infrared Transmitter/Receiver unit, please refer to p. 26 "10. INSTALLATION AND CONNECTIONS"

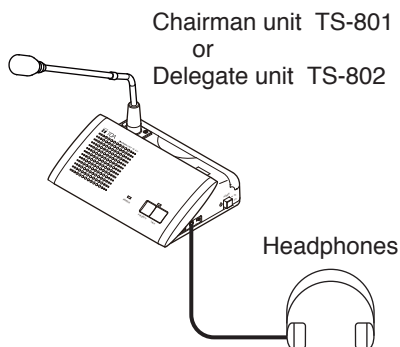

### Distributor block diagram

[YW-1022]

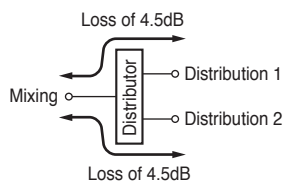

[YW-1024]

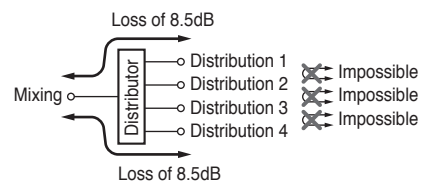

**Note:** To avoid an increase in loss, do not perform connections between distribution terminals.

## 9. INFRARED SERVICE AREAS

### 9.1. Infrared Transmitter/Receiver

• TS-905

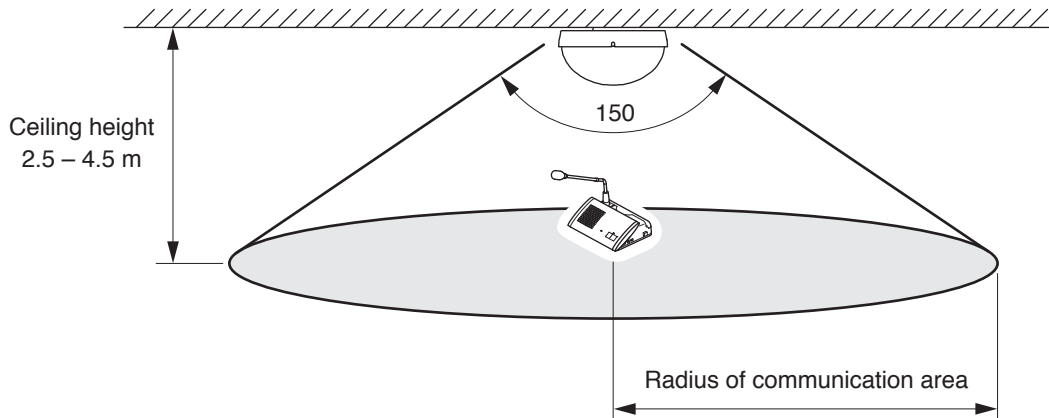

• TS-907

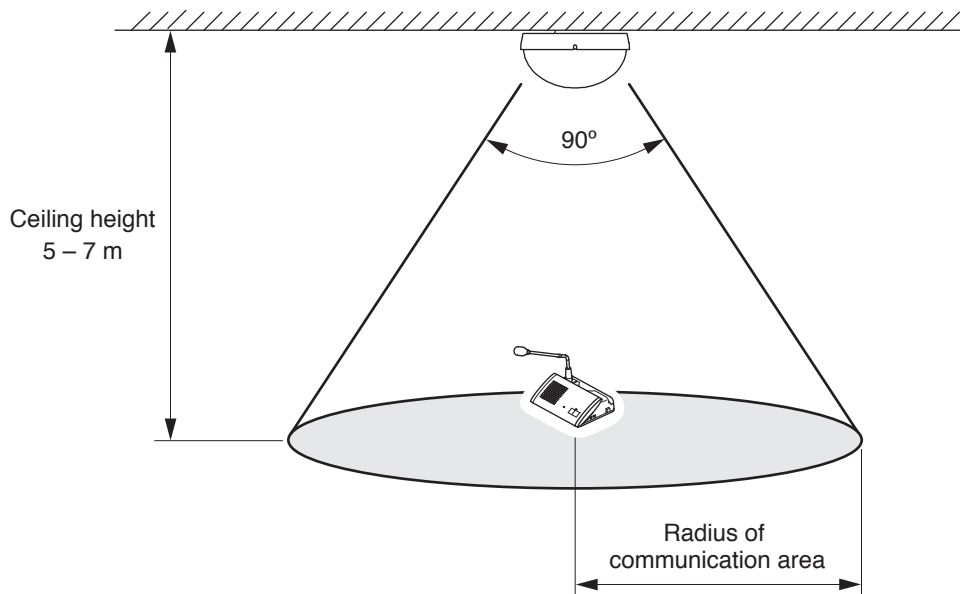

Model	Ceiling height	Radius of communication area
TS-905	2.5 m	Approx. 7.0 m
	3.0 m	
	3.5 m	Approx. 6.5 m
	4.0 m	
	4.5 m	
TS-907	5.0 m	Approx. 6.0 m
	5.5 m	
	6.0 m	
	6.5 m	
	7.0 m	

#### Notes

- Infrared signals cannot reach the Infrared Transmitter/Receiver unit if it is hidden behind the user or other objects. Install multiple Transmitter/Receiver units in line-of-sight from all Chairman and Delegate units.
- Install the Infrared Transmitter/Receiver units in such a way that each Chairman and Delegate unit can always communicate with two or more Transmitter/Receiver units. If installed in such a way that communication is only established with one Transmitter/Receiver unit, the infrared signal may be blocked by persons or other objects, possibly causing a momentary loss of signal reception.



## 9.2. Chairman Unit and Delegate Unit

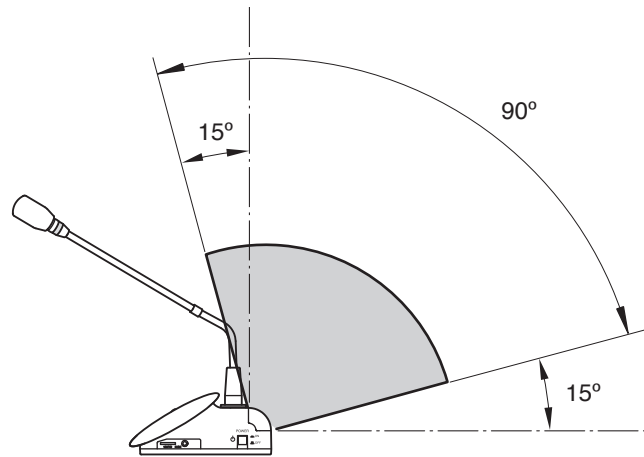
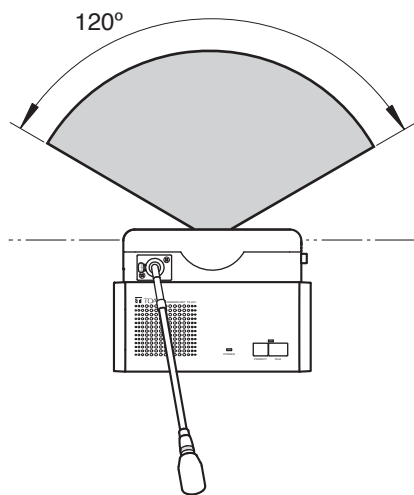
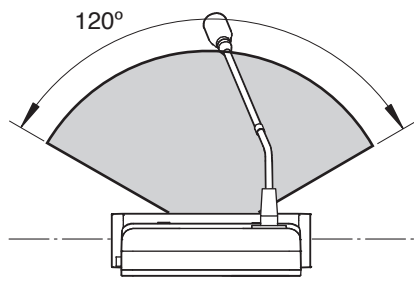

## 10. INSTALLATION AND CONNECTIONS

### 10.1. Notes on Installation of the Infrared Transmitter/Receiver Unit

Installing the Infrared Transmitter/Receiver unit in locations exposed to sunlight or in proximity to such infrared sources as fluorescent lights could result in system failures or the introduction of noise into the system. Avoid installing the Infrared Transmitter/Receiver unit in close proximity to infrared sources, as instructed below:

#### [Avoid direct sunlight]

- Cover windows with curtains or blinds to shield the unit from direct exposure to sunlight.
- Install the unit at least 2 – 3 meters away from the nearest window.

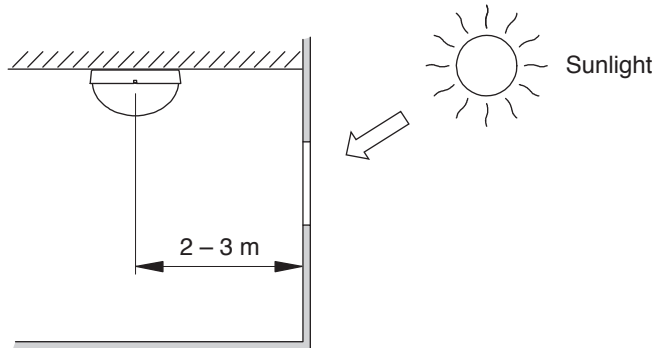

#### [Keep away from fluorescent lights]

Position the unit at least 50 cm away from fluorescent lights.

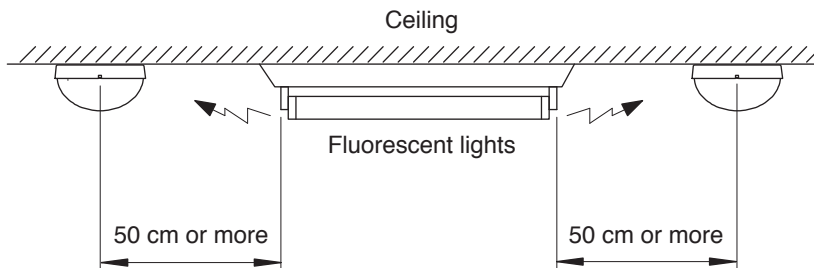

#### [Keep away other infrared light sources]

- Lighting equipment
- LCD projectors, overhead projectors, incandescent lamps, etc.
- Mercury-arc lamps
- Plasma displays
- Remote controllers, infrared microphones, infrared equipment such as infrared LANs.
- Dimmers

## 10.2. Infrared Transmitter/Receiver Unit Arrangement Examples

The area range that an Infrared Transmitter/Receiver unit covers differs depending on the height from the Chairman/Delegate units to the ceiling. (Refer to p. 24.)

Arrange the Infrared Transmitter/Receiver units so that all Chairman and Delegate units are included in the service area.

### Note

The maximum number of Infrared Transmitter/Receiver units to be installed is 16 when they are all TS-905 units and 12 when they are all TS-907 units. (Also 12 when both models are mixed.)

### [Conference room measuring 30 x 30 meters]

Arranging the units at intervals as illustrated permits the service area to cover every corner of the room.

### Note

Determine which to use TS-905 or TS-907 depending on the ceiling height.

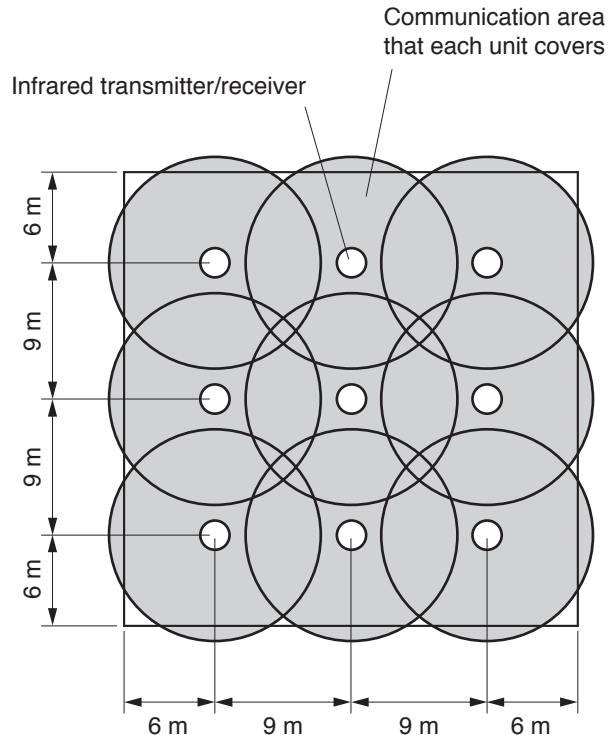

### [Conference room using round tables]

All Chairman and Delegate units are arranged around the table, in which case only one Infrared Transmitter/Receiver unit may suffice for complete coverage of conference communications.

However, it is highly recommended that two or more Transmitter/Receiver units be installed in order to avoid accidental interruptions of communications.

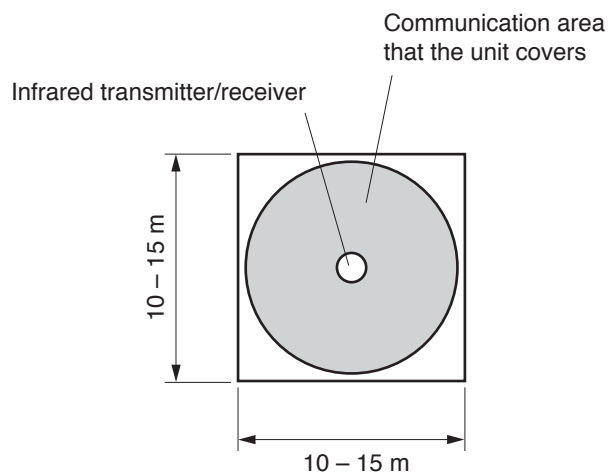

### 10.3. Wiring between the Infrared Transmitter/Receiver Unit and the Central Unit

#### 10.3.1. Notes on wiring

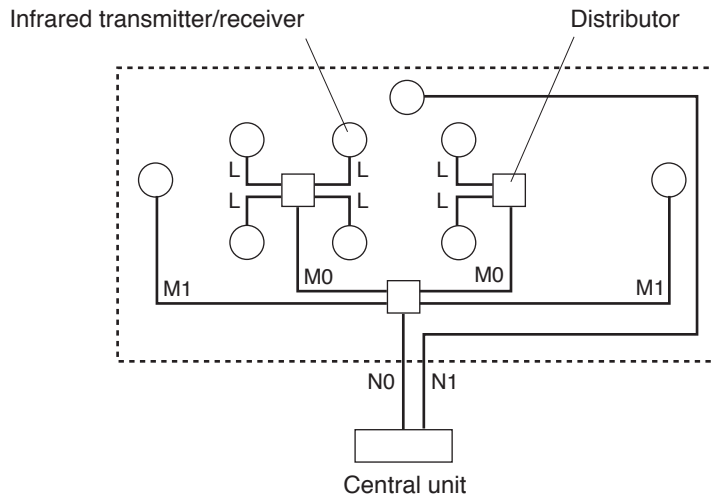

When two or more Infrared Transmitter/Receiver units receive infrared signals from the Chairman and Delegate units, the signal reception level increases if input signals to each Transmitter/Receiver unit are in phase. If not in phase, the signal reception level may decrease.

- To put signals in phase, ensure that the following cable length between two components are identical.

Length between each Infrared Transmitter/Receiver unit and the Central unit:  $L + M0 + N0 = M1 + N0 = N1$

**Note:** This distance must always be the same even if a distributor is included in the wiring.

Length between Infrared Transmitter/Receiver unit and distributor: L  
 Length between distributors (where two distributors are connected): M0  
 Length between distributor and Central unit: N0

(In the above figure, since there is only one N0 connection, the length need not be matched for the N0 line.)

- The maximum cable length between each Infrared Transmitter/Receiver unit and the Central unit differs depending on the type of coaxial cable to be used. (Refer to p. 46.)  
 Take care not to exceed the maximum cable length.

#### 10.3.2. Distributor use

- The YW-1022 is a 2-branch distributor, and the YW-1024 is a 4-branch distributor. In the case of the YW-1024, its distribution terminals may become idle depending on the Infrared Transmitter/Receiver unit's wiring. However, this presents no problem.
- Avoid connecting more than 2 distributors in series. Connecting 3 or more distributors increases high-frequency signal loss, and could result in system malfunction.
- It is possible to mix Infrared Transmitter/Receiver units not connected to any distributor, those connected to 1 distributor, and those connected to 2 distributors in the same system.

#### 10.3.3. Wiring examples

[Example 1]

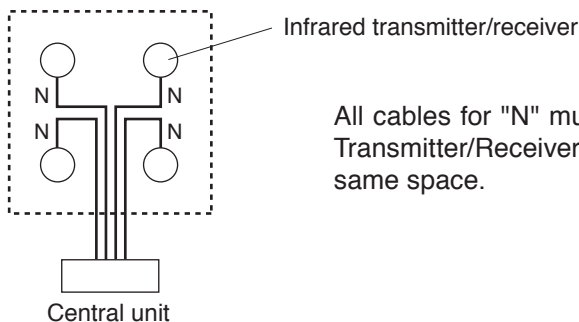

All cables for "N" must be identical in length when the Infrared Transmitter/Receiver unit and the Central unit are installed in the same space.

[Example 2]

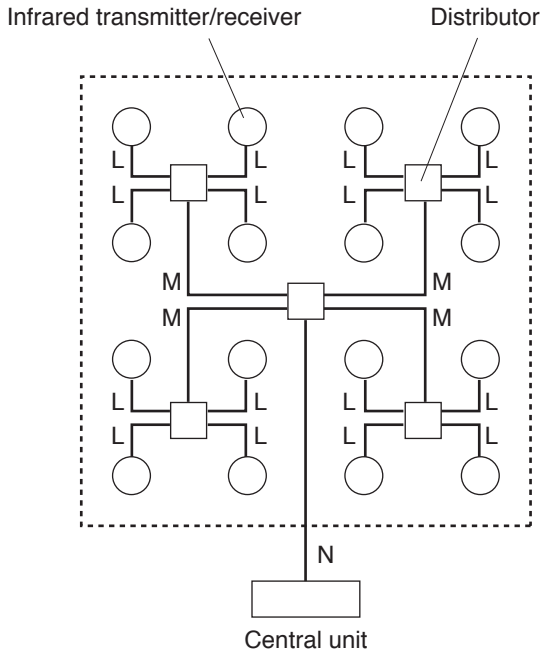

When installing in the same space,

- All "L" cables must be identical in length
- All "M" cables must be identical in length.

**Note**

To facilitate the unification of coaxial cables used in different connections into the same length, it is highly recommended that wiring from the Central unit to the distributor mounted in a ceiling be performed with a single cable. For other ceiling wiring, using pre-cut coaxial cables of a slightly longer length will facilitate making all connections the same length.

[Example 3]

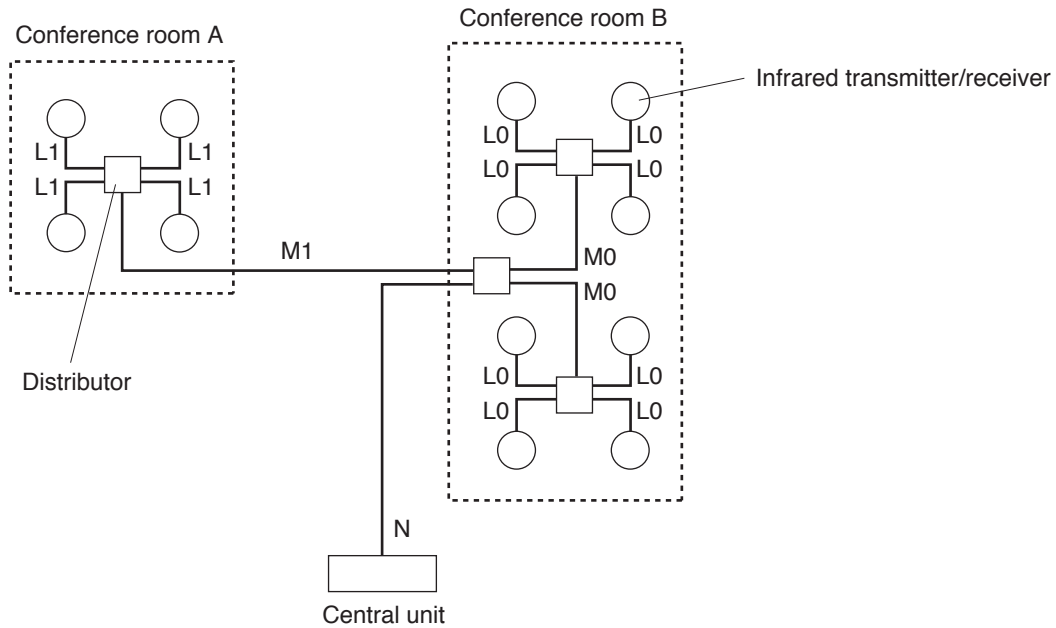

When installing in multiple rooms where the light is shut off, coaxial cables used in different rooms need not be matched to the same length.

- All L0 cables are the same length.
- All L1 cables are the same length.
- All M0 cables are the same length.
- L0 and L1 cables need not be the same, since they are used in different rooms.
- M0 and M1 cables need not be the same length, since they are used in different rooms.

**Note**

The above condition also applies to cases in which two conference systems, both including the Chairman and Delegate units, are apart from each other in the same room so that communications cannot be made between the two systems.

## 10.4. Mounting the Infrared Transmitter/Receiver Unit

### 10.4.1. Ceiling mounting

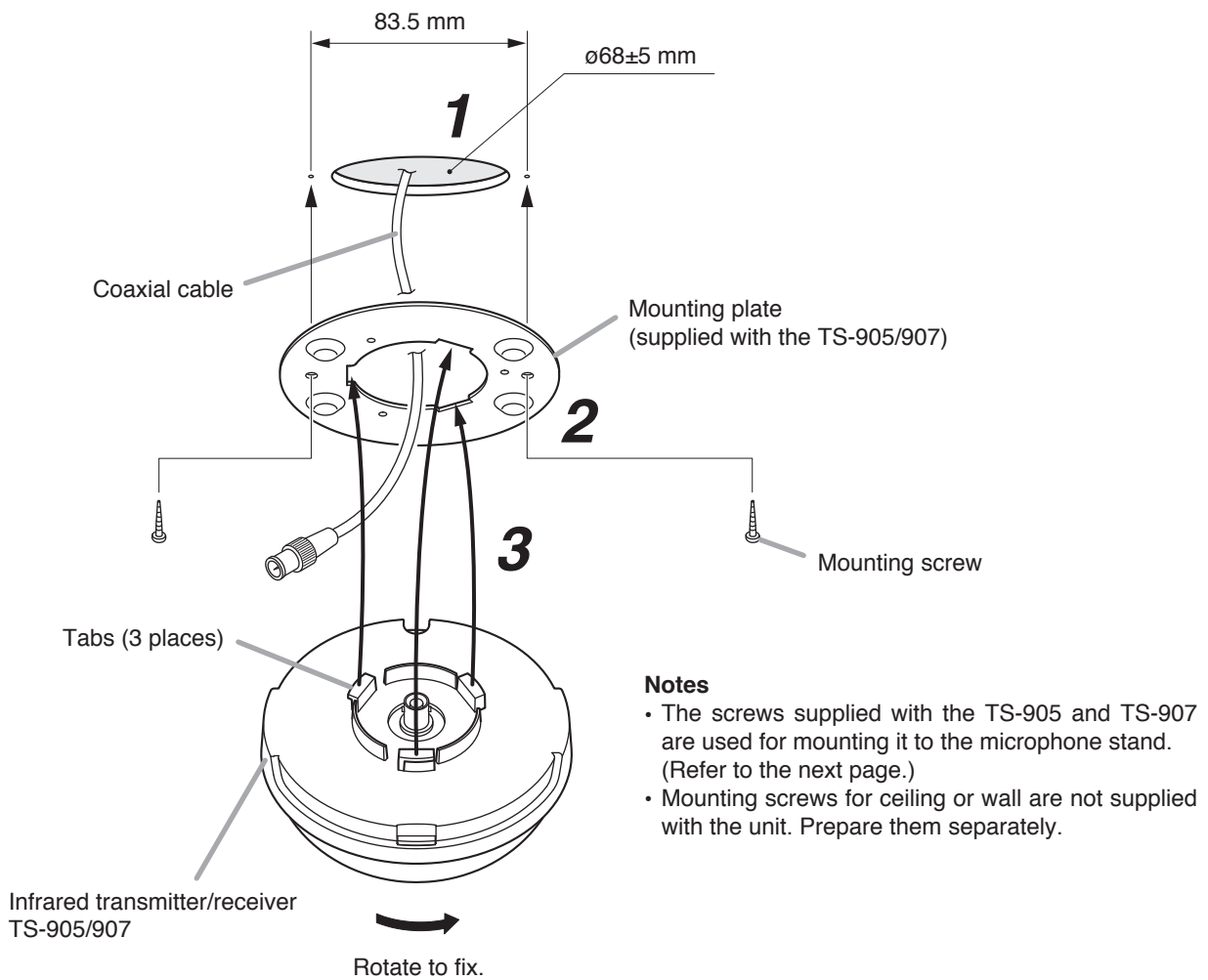

**Step 1.** Make a 68 mm diameter hole in the ceiling.

**Step 2.** Attach the supplied mounting plate to the ceiling panel.

#### Notes

- Since the distance between two mounting screw holes is 83.5 mm, the plate can also be mounted over an electrical box.
- For open wiring, use of an electrical box is recommended.
- When attaching the plate to an electrical box, use an L-shaped BNC plug or L-shaped conversion connector.

**Step 3.** After wiring completion, mount the Infrared Transmitter/Receiver unit to the mounting plate. With the unit's tabs (3 places) aligned with each corresponding notch in the mounting plate, rotate the Infrared Transmitter/Receiver unit clockwise till it stops and fits into place.

### 10.4.2. Mounting on a microphone stand

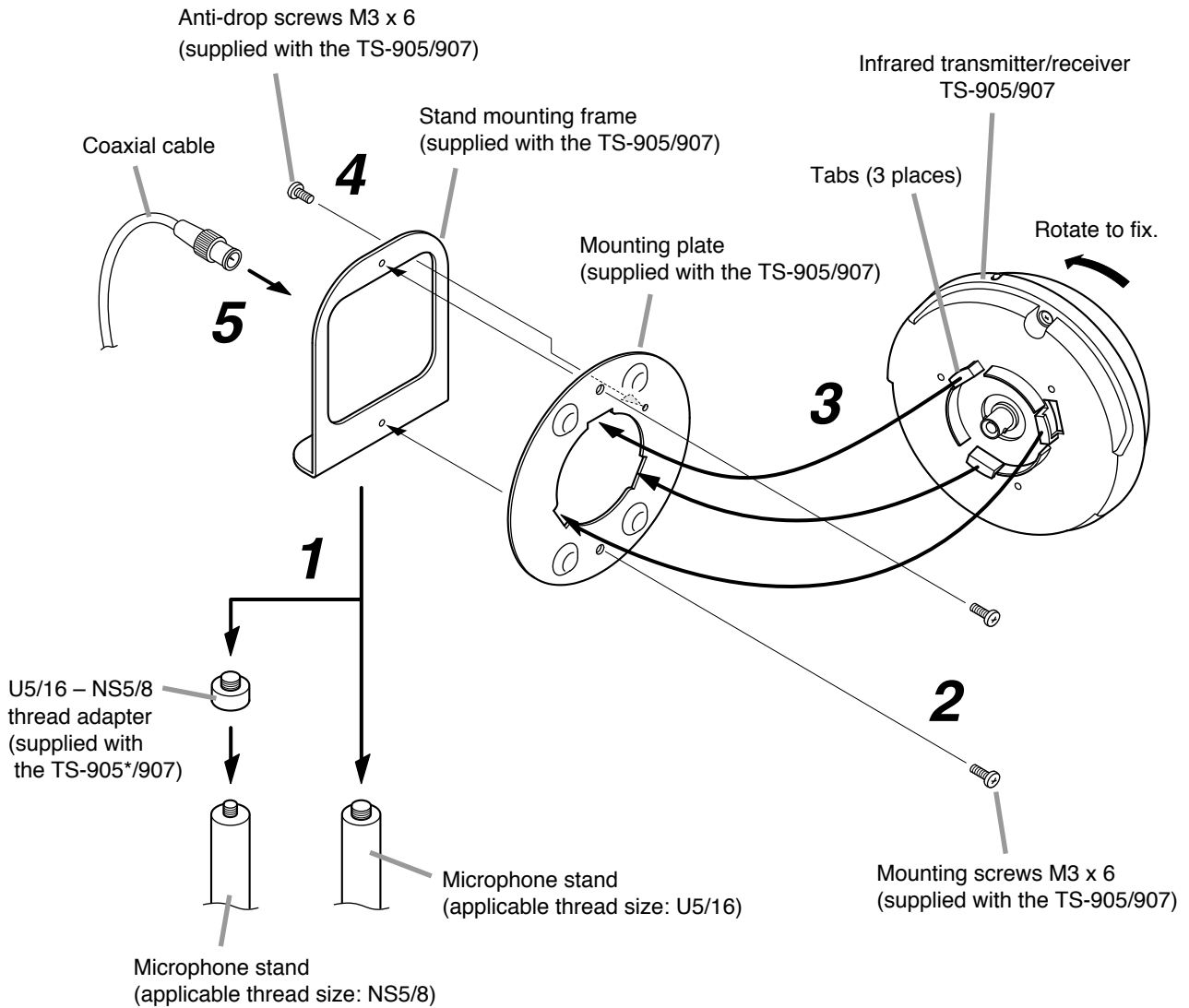

\* Not supplied with the TS-905 CE version.

- Step 1.** Attach the supplied stand mounting frame to the microphone stand.  
Applicable thread size is U 5/16.  
When the stand's thread size is NS 5/8, mount the supplied thread adapter onto the microphone stand.
- Step 2.** Fix the supplied mounting plate to the stand mounting frame.  
Use the two supplied M3 x 6 screws for mounting.
- Step 3.** Attach the Infrared Transmitter/Receiver unit to the mounting plate.  
Align the unit's tabs (3 places) with the corresponding notches in the plate, and then rotate the unit clockwise until it stops and fits into place.
- Step 4.** Mount an anti-drop screw to the mounting plate.  
**Note:** The screw tip enters a hole in the unit and prevents its rotation.
- Step 5.** Perform wiring.

## 10.5. Connections between the Infrared Transmitter/Receiver Unit and the Central Unit

### 10.5.1. Connecting

Use the coaxial cable with a BNC connector to connect the Infrared Transmitter/Receiver unit to the Central unit.

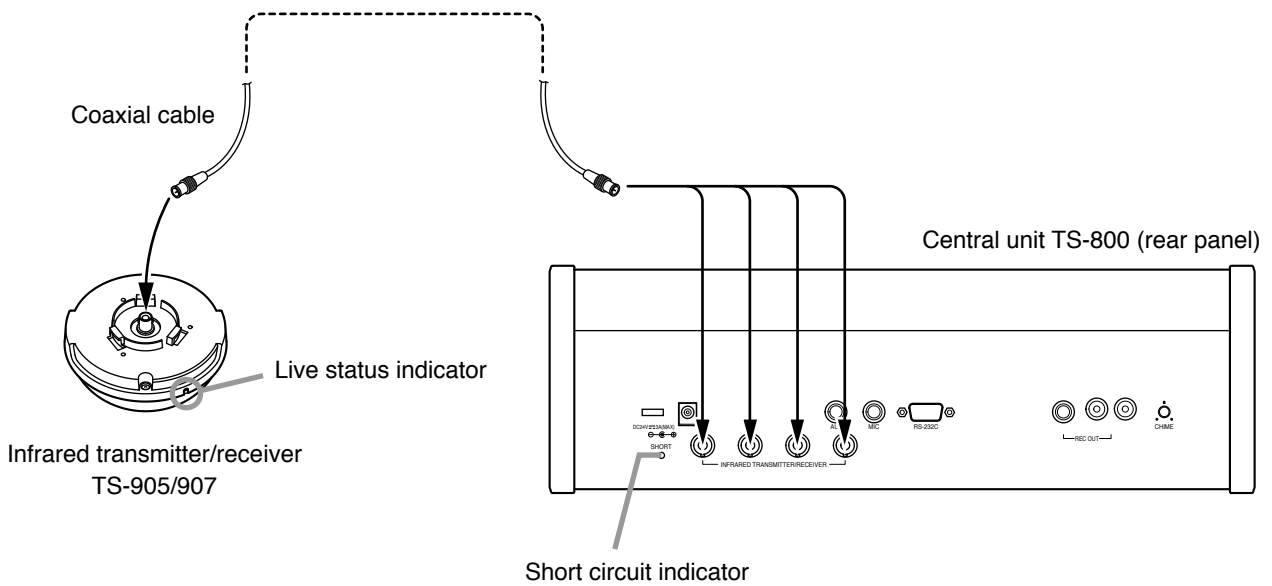

### Notes

- It is recommended that the RG-59/U, RG-6/U, or RG-11/U coaxial cable be used.
- Since the Infrared Transmitter/Receiver unit is equipped with the Live Status indicator, it is possible to confirm whether or not the coaxial cable is correctly connected. (The indicator cannot be used for confirmation of the unit's minimum operating voltage.)  
When the indicator does not light, it can be considered that the coaxial cable is not connected or shorted.
- The Central unit has a Short Circuit indicator on its rear panel and the Central unit's short circuit protection circuit is common to all 4 BNC terminals. If this short circuit indicator lights, locate the shorted point by removing each distributed cord. The indicator also lights when the number of Infrared Transmitter/Receiver units connected in the system exceeds the allowable limit.



### 10.5.2. Coaxial cable processing

Coaxial cable	Applicable BNC plug
RG-59/U	YA-641 (1 piece per package), CC-4900 (10 pieces per package), and CC-4901 (10 pieces per package)
RG-6/U	YA-641 (1 piece per package), CC-4900 (10 pieces per package)
RG-11/U	YA-642 (1 piece per package)

**Note:** Purchase both the coaxial cable and the required BNC plug separately.

Follow the procedure below to attach the BNC connector to the coaxial cable:

#### Attaching a YA-641 or CC-4901 BNC Plug to the RG-59/U Cable

**Step 1.** Strip the jacket 10 mm from the end of the coaxial cable.

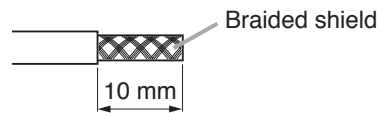

**Step 2.** Slip the tube supplied with the BNC plug over the jacket.

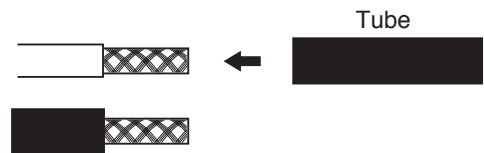

**Step 3.** Unravel the braided shield and turn it back, then peel away the aluminum cladding.



**Step 4.** Strip the dielectric 4 mm from the cable end.

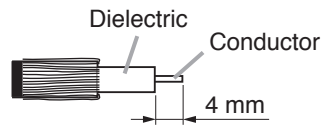

**Step 5.** Disassemble the BNC plug as shown in the figure at right and turn the screw on the plug so that it loosens partially but remains in position.

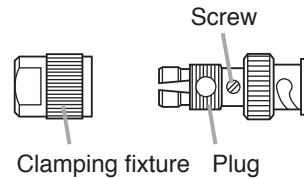

**Step 6.** Insert the coaxial cable into the clamping fixture.

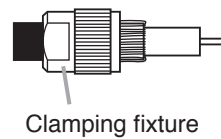

**Step 7.** Insert the clamping fixture assembly into the plug.

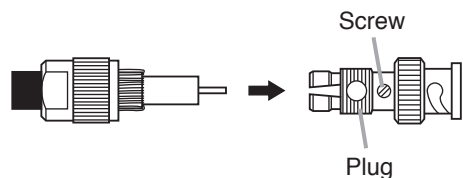

**Step 8.** Tighten the screw and then clamp the plug by tightening the clamping fixture.

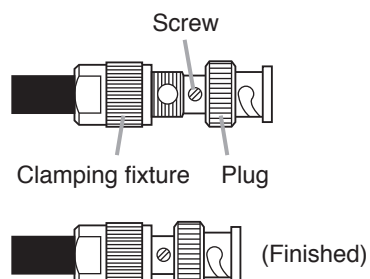

## Attaching a CC-4900 BNC Plug to the RG-59/U Cable

**Step 1.** Strip the jacket 10 mm from the end of the coaxial cable.

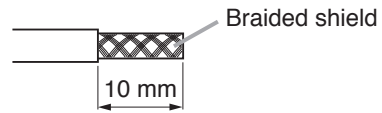

**Step 2.** Slip the tube supplied with the BNC plug over the jacket.

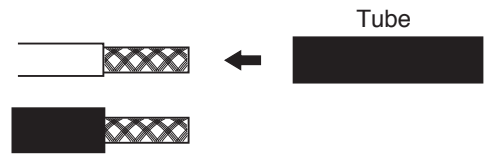

**Step 3.** Unravel the braided shield and turn it back, then peel away the aluminum cladding.



**Step 4.** Strip the dielectric 4 mm from the cable end.

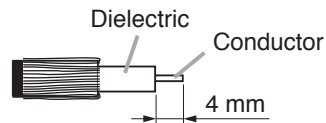

**Step 5.** Disassemble the BNC plug as shown in the figure at right.

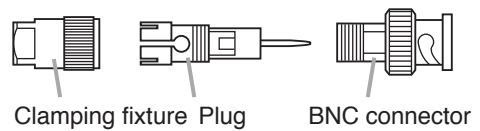

**Step 6.** Insert the coaxial cable into the clamping fixture.

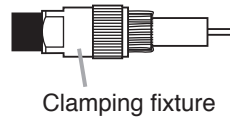

**Step 7.** Insert the clamping fixture assembly into the plug and then solder the conductor.

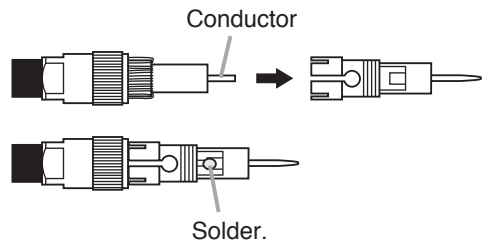

**Step 8.** Insert the plug into the BNC connector.

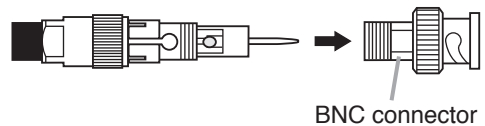

**Step 9.** Clamp the connector by tightening the clamping fixture.

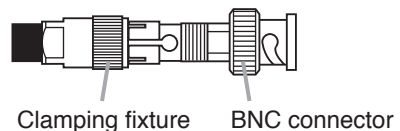

## Attaching a YA-641 BNC Plug to the RG-6/U Cable

**Step 1.** Strip the jacket 10 mm from the end of the coaxial cable.

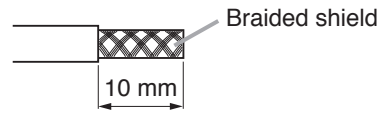

**Step 2.** Unravel the braided shield and turn it back, then peel away the aluminum cladding.



**Step 3.** Strip the dielectric 4 mm from the cable end.

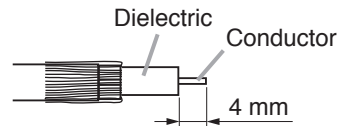

**Step 4.** Disassemble the BNC plug as shown in the figure at right and turn the screw on the plug so that it loosens partially but remains in position.

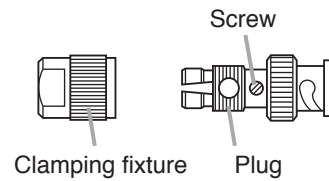

**Step 5.** Insert the coaxial cable into the clamping fixture.

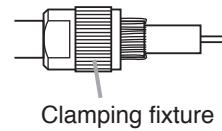

**Step 6.** Insert the clamping fixture assembly into the plug.

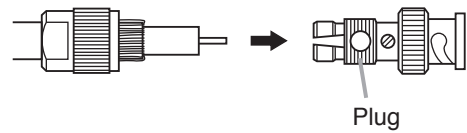

**Step 7.** Tighten the screw and then clamp the plug by tightening the clamping fixture.

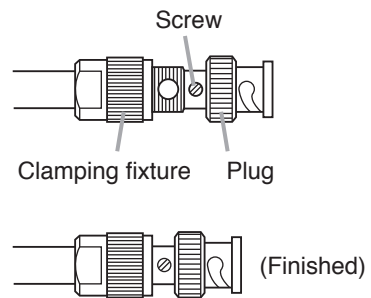

## Attaching a CC-4900 BNC Plug to the RG-6/U Cable

**Step 1.** Strip the jacket 10 mm from the end of the coaxial cable.

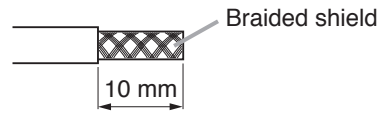

**Step 2.** Unravel the braided shield and turn it back, then peel away the aluminum cladding.



**Step 3.** Strip the dielectric 4 mm from the cable end.

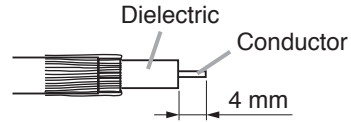

**Step 4.** Disassemble the BNC plug as shown in the figure at right.

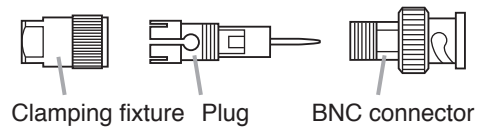

**Step 5.** Insert the coaxial cable into the clamping fixture.

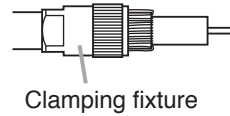

**Step 6.** Insert the clamping fixture assembly into the plug and then solder the conductor.

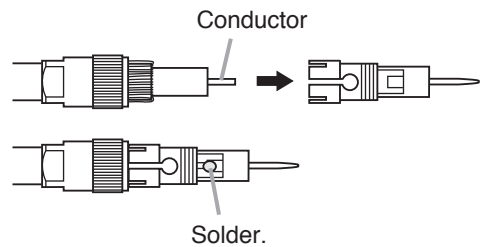

**Step 7.** Insert the plug into the BNC connector.

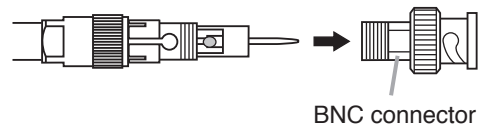

**Step 8.** Clamp the connector by tightening the clamping fixture.

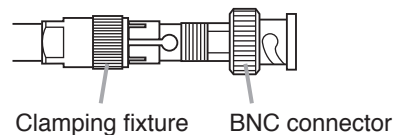

## Attaching a YA-642 BNC Plug to the RG-11/U Cable

**Step 1.** Disassemble the BNC plug as shown in the figure at right.

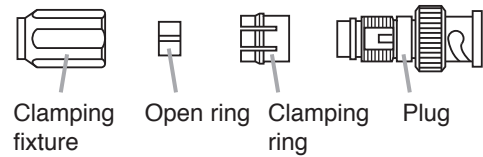

**Step 2.** Strip the jacket 15 mm from the end of the coaxial cable.

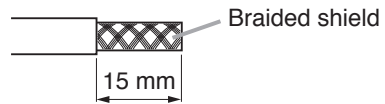

**Step 3.** Insert the coaxial cable into the open ring.



**Step 4.** Unravel the braided shield and turn it back, then peel away the aluminum cladding.



**Step 5.** Strip the dielectric 5 mm from the cable end.

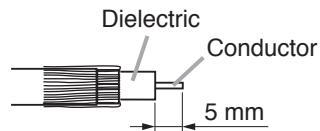

**Step 6.** Insert the coaxial cable into the clamping fixture.

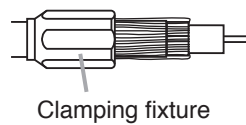

**Step 7.** Attach the clamping ring to the plug.

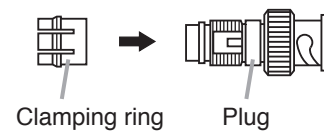

**Step 8.** Insert the clamping fixture assembly into the plug.

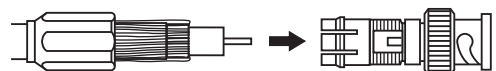

**Step 9.** Solder the conductor to the plug.

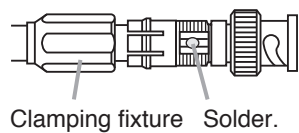

**Step 10.** Clamp the plug by tightening the clamping fixture.



## 10.6. Using Wired Microphones and Sound Source Equipment

### 10.6.1. Wired microphone use

Connect a wired microphone to the Central unit's MIC input and adjust its volume with the corresponding MIC input volume control.

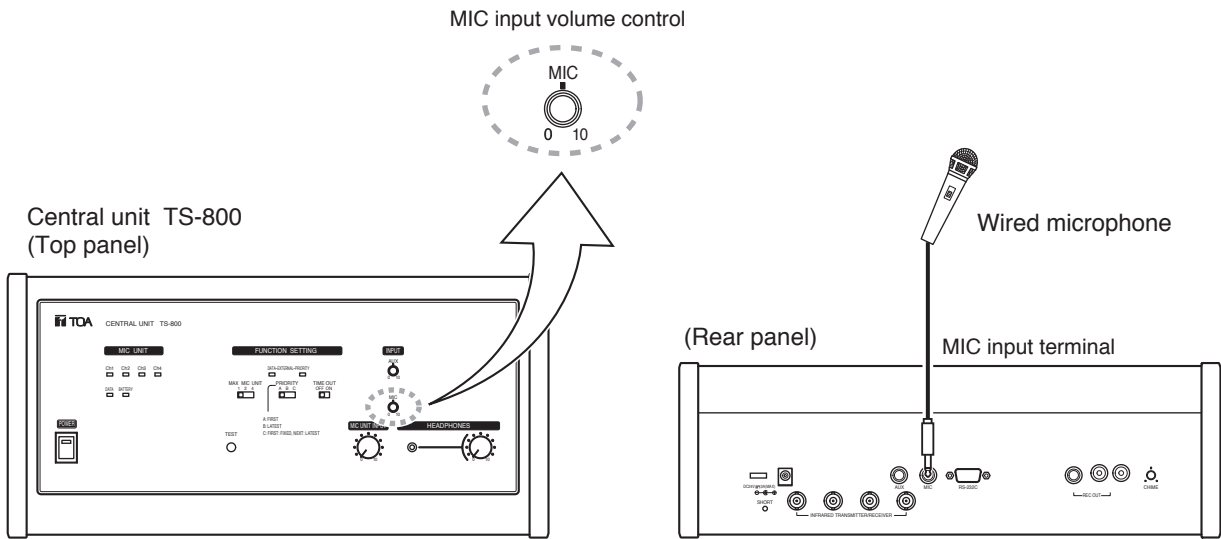

### 10.6.2. Sound source equipment use

Connect sound source equipment to the Central unit's AUX input and adjust its volume with the corresponding AUX input volume control.

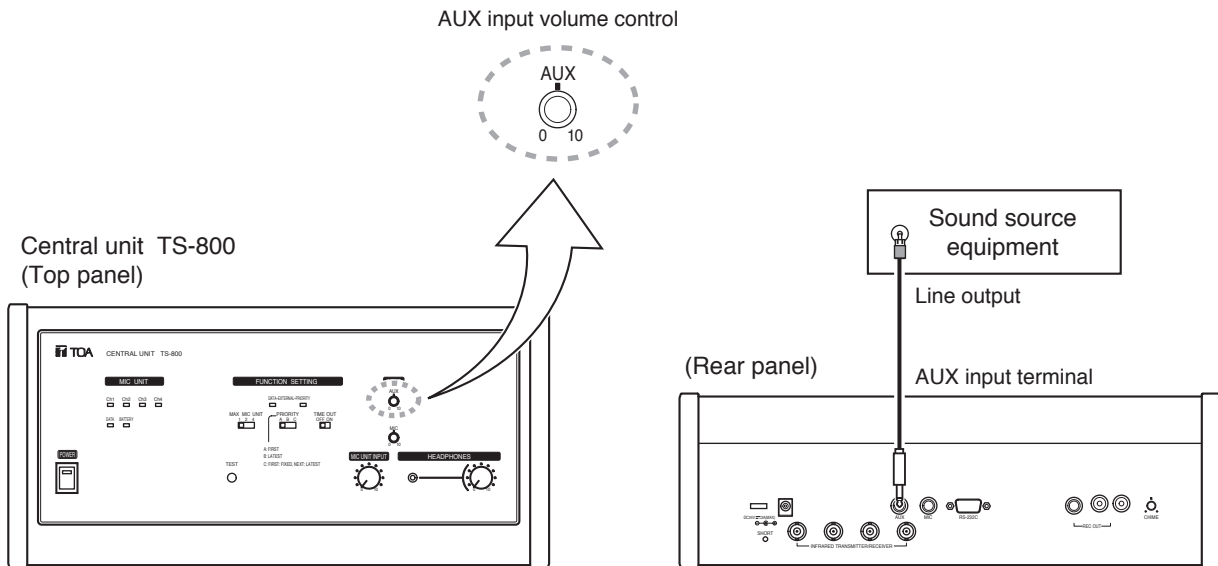

## 10.7. Recording the Conference Contents

Connect the recorder's recording input terminal to the Central unit's recording output terminal. If the recorder has its recording level control, adjust it to an appropriate recording level.

**Note:** For operation of the recorder, refer to the instruction manual included with the recorder.

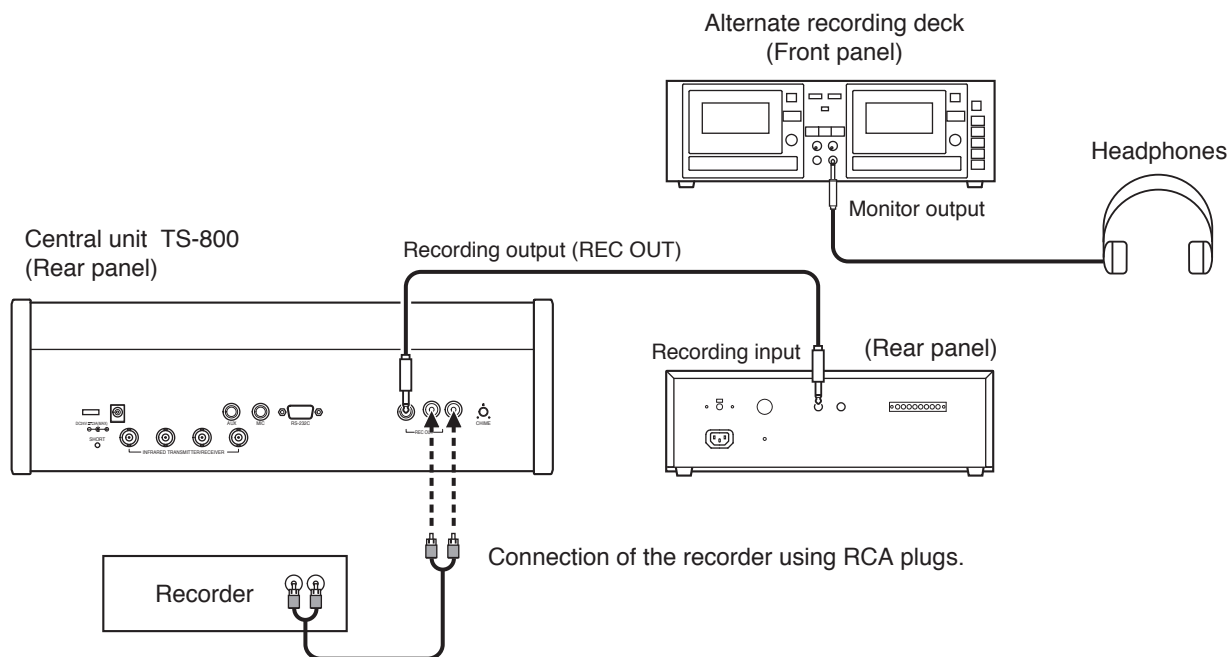

# 11. CHAIRMAN AND DELEGATE UNIT INSTALLATION AND SETTINGS

**Step 1.** Use a screwdriver to set the Unit address number setting switch located on the unit's bottom side. Set the unit address number (001 – 064), taking care to ensure that the same number is not duplicated in the system.

If the number [000] is assigned to a unit, the user of that unit cannot speak. However, the unit can be used for monitoring.

Set a numeral for the ones place and tens place.

As for the hundreds place, shift this switch to OFF for a numeral "0" and to ON for "1." Be sure to leave this switch in the OFF position.

**Note**

This number is factory-preset to [000].

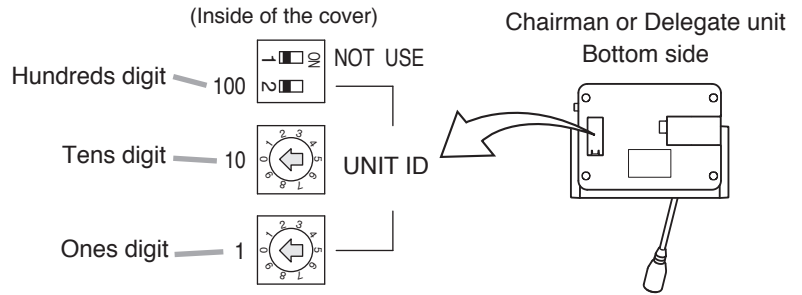

**Step 2.** Mount the microphone to the Chairman or Delegate unit.

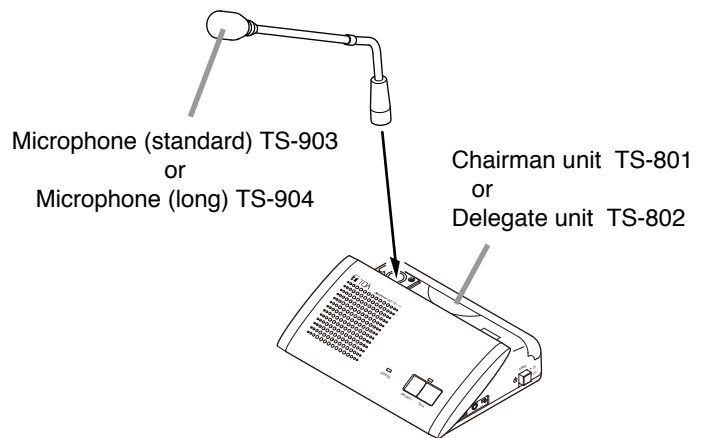

**Step 3.** Set the Priority operation, Priority chime mute, and Priority speech key operation functions using the DIP switch located on the Chairman unit's bottom side.

Setting switch	Factory-preset position
Priority operation setting switch	RESET
Priority chime mute setting switch	OFF
Priority speech key operation setting switch	PTT

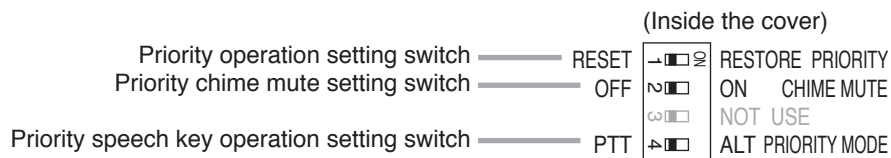
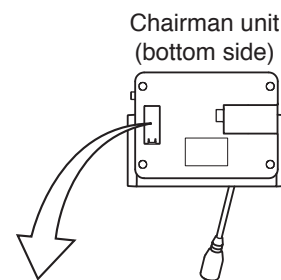

**Step 4.** Turn on the same number of microphones on the Chairman and Delegate units as the maximum number of simultaneous speakers set at the Central unit. Speaking into the microphone, adjust the Central unit's Speech volume control to an appropriate level.

**Step 5.** Initiate speech from the microphones of all Chairman and Delegate units, and confirm that acoustic feedback is not produced.

If feedback occurs, widen the distance between the Chairman unit and the Delegate unit or reduce the output volume to prevent feedback.



## 12. CHAIRMAN AND DELEGATE UNIT POWER SUPPLY

Use either the optional BP-900 Lithium-Ion Battery or the AD-0910 AC Adapter for the power supply of the Chairman and Delegate units.

### 12.1. BP-900 Lithium-Ion Battery

#### 12.1.1. Inserting the lithium-ion battery

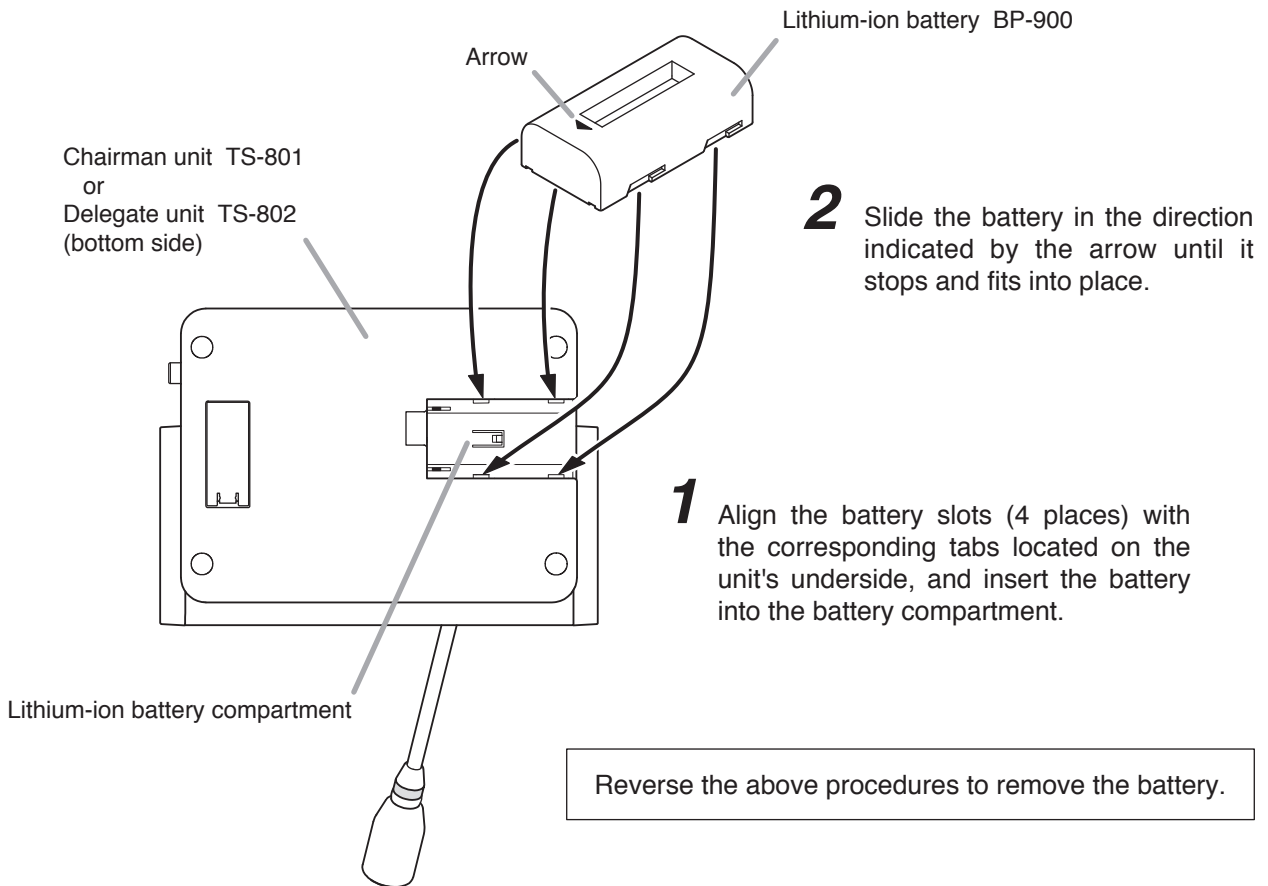

**Note:** A fully charged battery can be continuously used for about 10 hours.

### 12.1.2. Recharging

Use the BC-900 Battery Charger to recharge the BP-900 Lithium-Ion Battery.

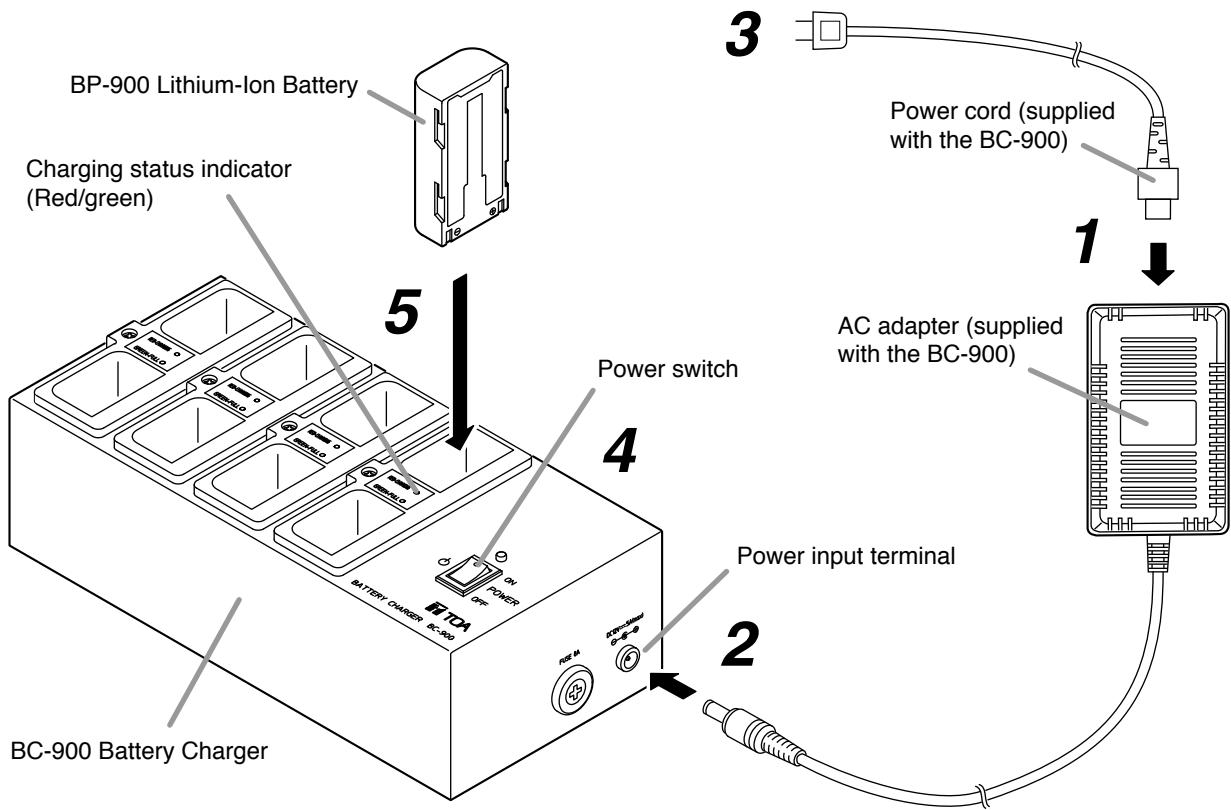

**Step 1.** Connect the power cord to the supplied AC adapter.

**Step 2.** Connect the AC adapter to the Charger's power input terminal.

**Step 3.** Insert the AC plug into the AC wall outlet.

**Step 4.** Turn on the power switch.  
The Power indicator lights green.

**Step 5.** Insert the battery fully into one of the Charger's battery receptacles with the battery oriented to the proper direction.  
Ensure that the charging status indicator lights red. If it does not light, check to see if the battery is correctly inserted.

Charging is completed within 5 hours and the charging status indicator lights green.

#### **WARNING**

Stop charging if batteries are not fully charged within 5 hours. Continuously charging over 5 hours may cause batteries to fire, explode, leak, or heat.

#### **CAUTION**

Remove the power supply plug of charger from the AC outlet after charging completion, as doing otherwise may cause a fire.

#### **Note**

Switching the Charger's power OFF and back ON again with fully-charged (charging completed) batteries inserted will result in repeated recharge of the batteries. Battery life could deteriorate from this repetitive charging.

## 12.2. AD-0910 AC Adapter

Connect the AD-0910 AC Adapter to the DC Inlet located on the left side panel of the Chairman and Delegate units.

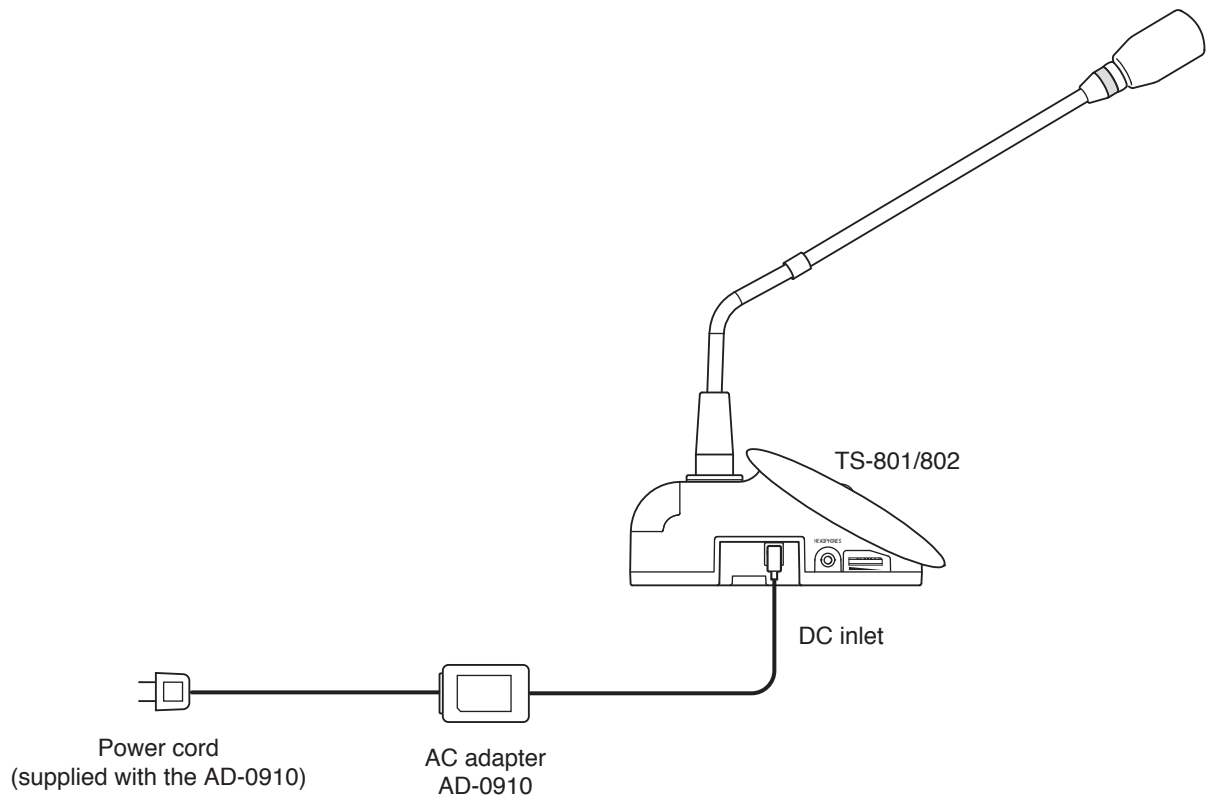

## 13. CENTRAL UNIT RACK MOUNTING

**Step 1.** Detach both side panels of the TS-800 Central Unit.  
Removed screws are used in Step 2.

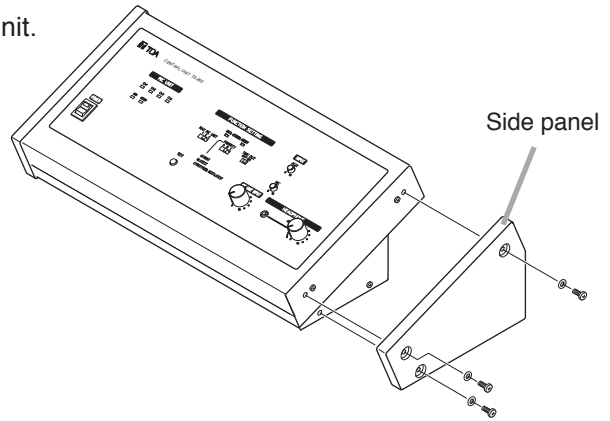

**Step 2.** Attach the MB-TS900 Rack Mounting Bracket to both sides of the Central Unit.  
Use the screws removed in Step 1.

**Step 3.** Mount the Central unit equipped with the mounting brackets in the rack.  
Use the rack mounting screws and fiber washers supplied with the rack mounting bracket.

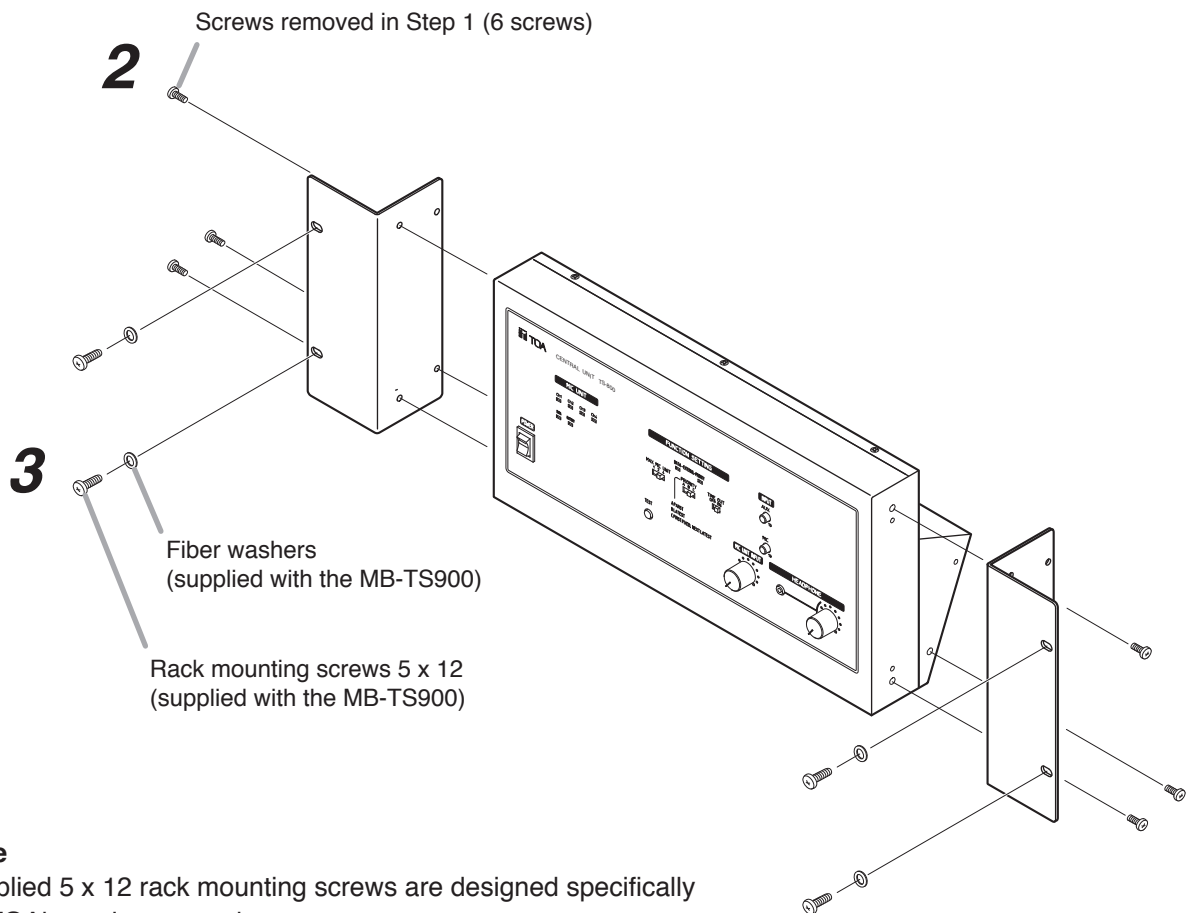

**Note**

Supplied 5 x 12 rack mounting screws are designed specifically for TOA's equipment rack.  
Avoid using them for other rack mounting.

## 14. INSTALLATION STATUS CONFIRMATION

Installation status for the Infrared Transmitter/Receiver unit, Chairman unit, and Delegate units can be checked from the Central unit. Switch on the power to the Chairman and Delegate units to confirm their installation status after completing installation and connection.

### Note

None of the unit's functions can be used while in installation status confirmation mode, except Priority Speech initiated from the Chairman unit.

**Step 1.** Switch on the power to the Central unit while holding down its Installation Check button .  
The Central unit's Battery indicator lights, placing the unit in installation confirmation mode.

**1-1.** When a connection check signal is output from the Central unit, the microphone indicator on the Chairman or Delegate unit that has received the signal flashes.

**1-2.** An acknowledgement signal is transmitted from each Chairman or Delegate unit.

**1-3.** A response confirmation signal is output from the Central unit that has received the acknowledgement signal, and the microphone indicator on the Chairman or Delegate unit that has received the signal changes from flashing to steady ON.

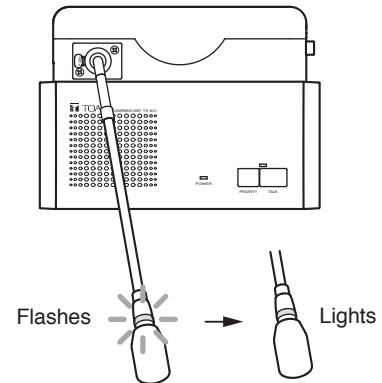
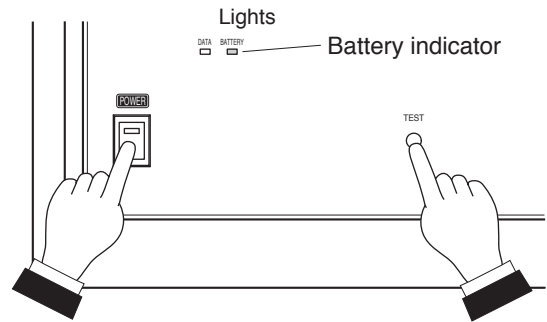

**Step 2.** Press the Installation Check button for 1 second or more after confirming the indication.  
The Central unit's Battery indicator turns off.  
The microphone indicators on the Chairman and Delegate units also extinguish, and the installation status confirmation mode is terminated, returning the system to normal operation mode.

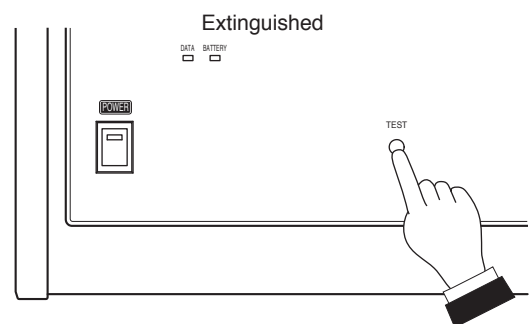

## 15. APPENDIX

(Finding the maximum cable length between the Central Unit and the Infrared Transmitter/Receiver Unit)

Values calculated here are given only as guidelines, since they can vary depending on ambient building conditions and the Infrared Transmitter/Receiver unit.

### 15.1. Confirming the Wiring Design

To obtain the maximum cable length between the Infrared Transmitter/Receiver unit and the Central unit, calculate the cable length on the following each condition. The shorter length of the two results is the required extendable length.

- (1) Maximum allowable wiring loss: 20 dB (Total cable and distributor loss)
- (2) Maximum allowable DC voltage drop: 5 V

Values necessary for each calculation are as follows.

#### 15.1.1. Values necessary for calculating the loss

- (1) 2-branch distributor (YW-1022) loss: 4.5 dB
- (2) 4-branch distributor (YW-1024) loss: 8.5 dB
- (3) Coaxial cable loss per 100 m (table shown below)

RG-59/U	3.3 dB
RG-6/U	2.7 dB
RG-11/U	2.0 dB

**Note:** The values in the table above are losses at 10 MHz.

#### 15.1.2. Values necessary for calculating the voltage drop

- (1) Operating current per Infrared Transmitter/Receiver unit: 0.1 A (TS-905), 0.13 A (TS-907)
- (2) Distributor resistance loss: 0  $\Omega$
- (3) Coaxial cable loop resistance per 100 m (table shown below)

RG-59/U	16.82 $\Omega$
RG-6/U	12.82 $\Omega$
RG-11/U	2.4 $\Omega$

**Note:** The values in the table above are losses at 10 MHz.

**Note:** Coaxial cable loss and loop resistance values used here are based on our investigation.

## 15.2. Computational Equation

### 15.2.1. Finding the wiring loss

Requirement: Total loss  $\leq 20$  dB

Cable loss = (Length / 100) x Loss per 100 m

Total loss = Cable 1 loss + Cable 2 loss + Cable 3 loss + Distributor 1 loss + Distributor 2 loss

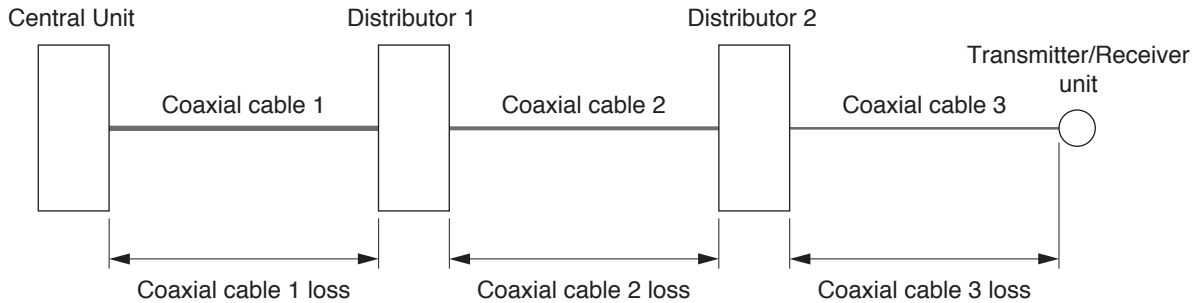

### 15.2.2. Finding the wiring voltage drop

Requirement: Total voltage drop  $\leq 5$  V

Cable voltage drop = (Length / 100) x Loop resistance per 100 m x Current

Cable current = Number of the connected Infrared Transmitter/Receiver units x 0.1 (TS-905) or 0.13 (TS-907)

Total voltage drop = Voltage drop 1 + Voltage drop 2 + Voltage drop 3

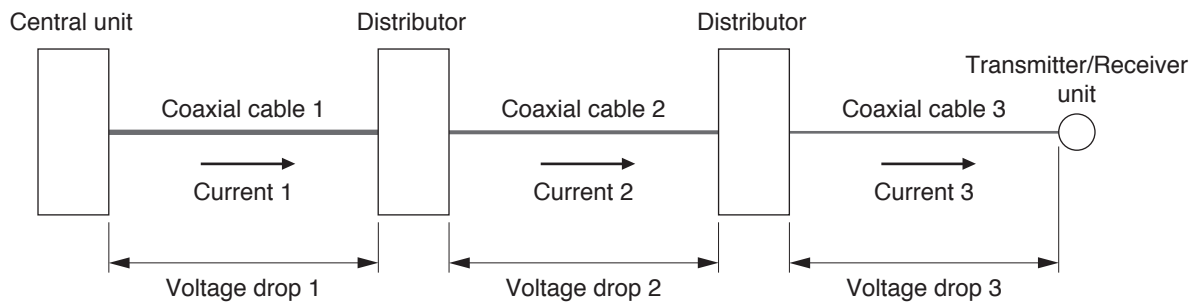

**Note:** For the coaxial cable required to carry a large current, use a cable of low loop resistance type.

#### [Finding the cable current]

Cable current = Number of the connected Infrared Transmitter/Receiver units x 0.1 (TS-905) or 0.13 (TS-907)

The cable current changes when the Distributor is used, as shown below.

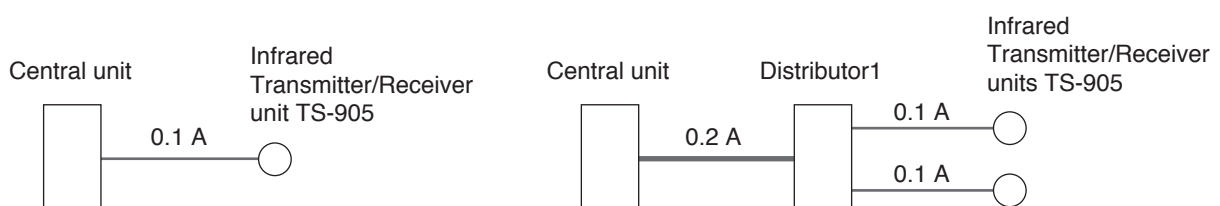

### 15.3. Design Examples

#### 15.3.1. Example 1: When installing 4 TS-905 Infrared Transmitter/Receiver units using 4 coaxial cables reaching from the Central unit:

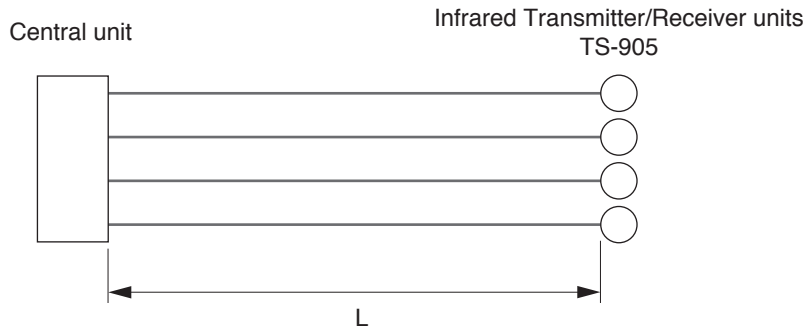

#### 1) Finding the maximum cable length using maximum allowable cable losses

Assuming that the type of coaxial cable used is RG-59/U,

$$\begin{aligned} \text{Maximum cable length } L &= (\text{Coaxial cable loss} / \text{its cable loss per } 100 \text{ m}) \\ &= (20 \text{ dB} / 3.3 \text{ dB}) \times 100 \text{ m} \\ &= 606 \text{ m} \end{aligned}$$

The following table shows the maximum allowable cable length for each type of coaxial cable.

RG-59/U	606 m
RG-6/U	740 m
RG-11/U	1000 m

#### 2) Finding the maximum cable length using voltage drop

Since one TS-905 Infrared Transmitter/Receiver unit is connected per coaxial cable, the current that flows through each coaxial cable is 0.1 A.

Assuming that the type of coaxial cable used is RG-59/U,

$$\begin{aligned} \text{Maximum length } L &= \{ (\text{Voltage drop } 1 / \text{Current } 1) / \text{Coaxial cable loop resistance } 1 \text{ for } 100 \text{ m} \} \\ &= \{ (5 \text{ V} / 0.1 \text{ A}) / 16.82 \Omega \} \times 100 \text{ m} \\ &= 297 \text{ m} \end{aligned}$$

The following table shows the maximum allowable cable length for each type of coaxial cable.

RG-59/U	297 m
RG-6/U	390 m
RG-11/U	2083 m

The table below shows the required maximum cable length for the example 1, the shorter length of the calculation results (1) and (2) above.

RG-59/U	297 m
RG-6/U	390 m
RG-11/U	1000 m



**15.3.2. Example 2: When installing 4 TS-905 Infrared Transmitter/Receiver units using 1 coaxial cable reaching from the Central unit (one 4-branch distributor connected):**

Condition: Cable length between the Distributor and the TS-905 Infrared Transmitter/Receiver unit is assumed to be 50 meters.

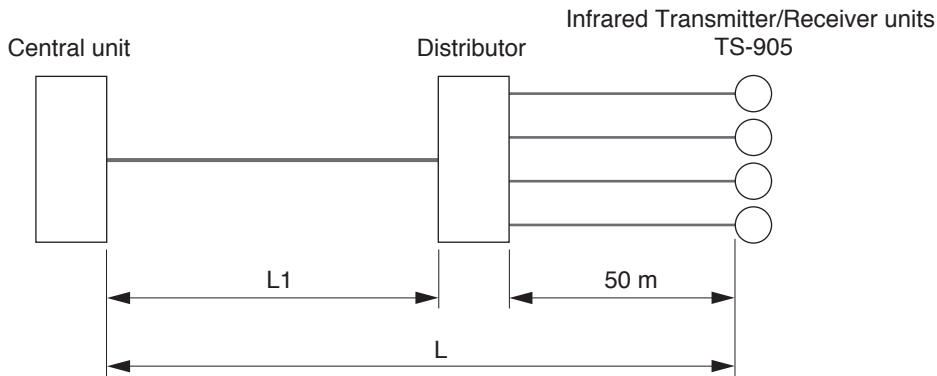

**1) Finding the maximum cable length using maximum allowable cable losses**

Assuming that RG-59/U coaxial cable is used between the Distributor and the Infrared Transmitter/Receiver unit, the cable loss between the two is calculated by the following equation:

$$\text{Cable loss} = 3.3 \text{ dB} \times (50 \text{ m} / 100 \text{ m}) = 1.65 \text{ dB}$$

Since the Distributor's internal loss is 8.5 dB, the maximum allowable loss between the Central unit and the Distributor becomes 9.85 dB (20 dB – 1.65 dB – 8.5 dB).

When RG-6/U coaxial cable is used between the Central unit and the Distributor, the length L1 between the two is,

$$\begin{aligned} L1 &= (\text{Coaxial cable loss} / \text{its cable loss per } 100 \text{ m}) \\ &= (9.85 \text{ dB} / 2.7 \text{ dB}) \times 100 \text{ m} \\ &= 364 \text{ m} \end{aligned}$$

Maximum cable length L between the Central unit and the Infrared Transmitter/Receiver unit is calculated by the following equation:

$$\begin{aligned} L &= L1 + 50 \text{ m} \\ &= 364 \text{ m} + 50 \text{ m} \\ &= 414 \text{ m} \end{aligned}$$

Similarly calculated for other types of coaxial cables, the maximum cable length between the Central unit and the Infrared Transmitter/Receiver unit is found in the following table.

RG-59/U	348 m
RG-6/U	414 m
RG-11/U	542 m

**2) Finding the maximum cable length using voltage drop**

The current flowing from the Distributor into each coaxial cable connected to the TS-905 Infrared Transmitter/Receiver unit is 0.1 A, since the number of Infrared Transmitter/Receiver units connected to each coaxial cable is 1.

Assuming that RG-59/U coaxial cable is used, the voltage drop between the Distributor and the Infrared Transmitter/Receiver unit is calculated by the following equation:

$$\begin{aligned} \text{Voltage drop} &= 16.82 \Omega \times (50 \text{ m} / 100 \text{ m}) \times 0.1 \text{ A} \\ &= 0.841 \text{ V} \end{aligned}$$

A remaining voltage of 4.159 V (5 V – 0.841 V) is the maximum allowable voltage drop between the Central unit and the Distributor. The current that flows between the two is 0.4 A.

When RG-6/U coaxial cable is used between the Central unit and the Distributor, the cable length L1 between the two is,

$$\begin{aligned} L1 &= \{ (\text{Voltage drop } 1 / \text{Current } 1) / \text{Coaxial cable loop resistance } 1 \text{ per } 100 \text{ m} \} \\ &= \{ (4.159 \text{ V} / 0.4 \text{ A}) / 12.82 \Omega \} \times 100 \text{ m} \\ &= 81 \text{ m} \end{aligned}$$

Maximum cable length L between the Central unit and the Infrared Transmitter/Receiver unit is calculated by the following equation:

$$\begin{aligned} L &= L1 + 50 \text{ m} \\ &= 81 \text{ m} + 50 \text{ m} \\ &= 131 \text{ m} \end{aligned}$$

Similarly calculated for other types of coaxial cables, the maximum cable length between the Central unit and the Infrared Transmitter/Receiver unit is found in the following table.

RG-59/U	111 m
RG-6/U	131 m
RG-11/U	483 m

The table below shows the required maximum cable length for the example 2, the shorter length of the calculation results (1) and (2) above.

RG-59/U	111 m
RG-6/U	131 m
RG-11/U	483 m

**15.3.3. Example 3: When installing each 4 TS-905 Infrared Transmitter/Receiver units using 4 coaxial cables reaching from the Central unit (four 4-branch distributors connected):**

Condition: Cable length between the Distributor and the TS-905 Infrared Transmitter/Receiver unit is assumed to be 50 meters.

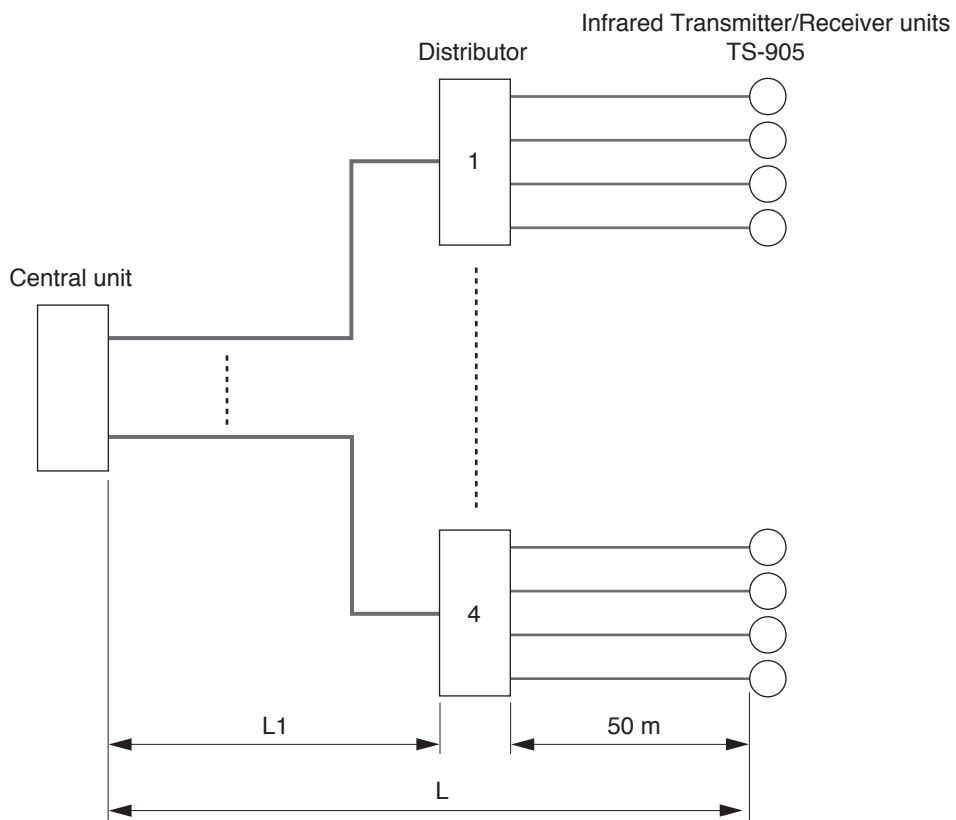

The equation and maximum cable length in this example are the same as those in Example 2 in the previous section on p. 49.

**15.3.4. Example 4: When installing 16 TS-905 Infrared Transmitter/Receiver units using 1 coaxial cable reaching from the Central unit (five 4-branch distributors connected):**

Condition: Length between the Distributor 2 and the TS-905 Infrared Transmitter/Receiver unit is assumed to be 50 meters, and the length between Distributor 1 and Distributor 2 10 meters.

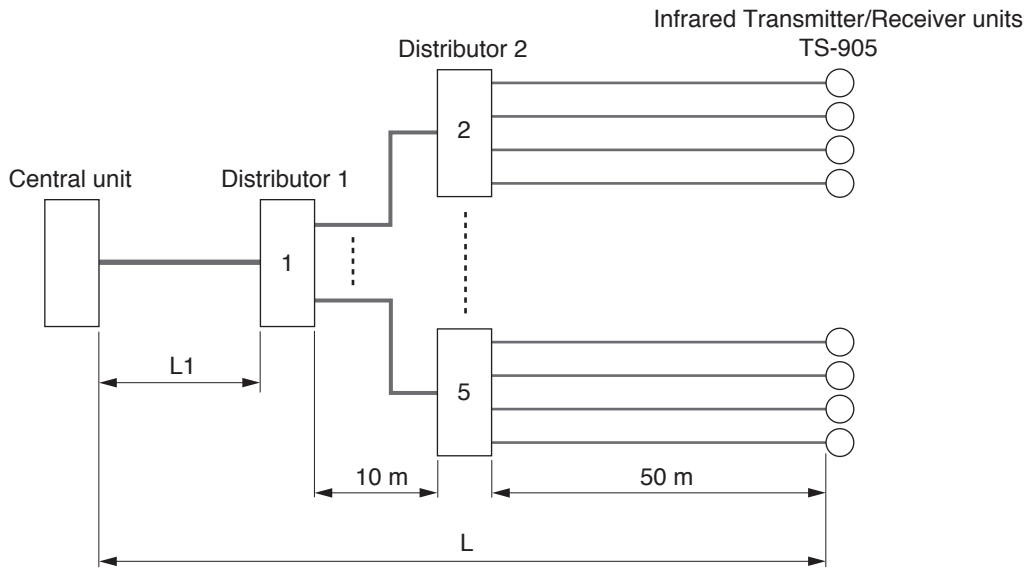

**1) Finding the maximum length using maximum allowable cable losses**

Assuming that RG-59/U coaxial cable is used, the cable loss between the Distributor 2 and the Infrared Transmitter/Receiver unit is calculated by the following equation:

$$\text{Cable loss} = 3.3 \text{ dB} \times (50 \text{ m} / 100 \text{ m}) = 1.65 \text{ dB}$$

Assuming that RG-6/U coaxial cable is used, the cable loss between the Distributor 1 and Distributor 2 is calculated by the following equation:

$$\text{Cable loss} = 2.7 \text{ dB} \times (10 \text{ m} / 100 \text{ m}) = 0.27 \text{ dB}$$

Because of the 2 serially-connected 4-branch distributors, their loss is 17 dB (8.5 dB + 8.5 dB), which is added to the above cable loss, causing a total loss of 18.92 dB (1.65 dB + 0.27 dB + 17 dB). Therefore, the maximum allowable cable loss between the Central unit and the Distributor 1 is calculated to be 1.08 dB (20 dB – 18.92 dB).

- Assuming that RG-11/U coaxial cable is used, L1 between the Central unit and the Distributor 1 is calculated by the following equation:

$$\begin{aligned} L1 &= (\text{Coaxial cable loss} / \text{its cable loss per } 100 \text{ m}) \\ &= (1.08 \text{ dB} / 2 \text{ dB}) \times 100 \text{ m} \\ &= 54 \text{ m} \end{aligned}$$

$$\begin{aligned} \text{Maximum cable length } L \text{ (Length between the Central unit and the Infrared Transmitter/Receiver unit)} \\ &= 54 \text{ m} + 10 \text{ m} + 50 \text{ m} = 114 \text{ m} \end{aligned}$$

- Assuming that RG-6/U coaxial cable is used, L1 between the Central unit and the Distributor 1 is calculated by the following equation:

$$\begin{aligned} L1 &= (\text{Coaxial cable loss} / \text{its cable loss per } 100 \text{ m}) \\ &= (1.08 \text{ dB} / 2.7 \text{ dB}) \times 100 \text{ m} \\ &= 40 \text{ m} \end{aligned}$$

$$\begin{aligned} \text{Maximum cable length } L \text{ (Length between the Central unit and the Infrared Transmitter/Receiver unit)} \\ &= 40 \text{ m} + 10 \text{ m} + 50 \text{ m} = 100 \text{ m} \end{aligned}$$

Similarly calculated for other types of coaxial cables, the maximum cable length between the Central unit and the Infrared Transmitter/Receiver unit is found in the table.

RG-59/U	92 m
RG-6/U	100 m
RG-11/U	114 m

## 2) Finding the maximum cable length using voltage drop

The current flowing from the Distributor 2 into each coaxial cable connected to the TS-905 Infrared Transmitter/Receiver unit is 0.1 A, since the number of Infrared Transmitter/Receiver units connected to each coaxial cable is 1.

Assuming that RG-59/U coaxial cable is used, the voltage drop between the Distributor 2 and the Infrared Transmitter/Receiver unit is calculated by the following equation:

$$\begin{aligned} \text{Voltage drop} &= 16.82 \, \Omega \times (50 \, \text{m} / 100 \, \text{m}) \times 0.1 \, \text{A} \\ &= 0.841 \, \text{V} \end{aligned}$$

When RG-6/U type coaxial cable is used, since the current flowing into each coaxial cable between Distributor 1 and Distributor 2 is 0.4 A, the voltage drop between the two is calculated by the following equation:

$$\begin{aligned} \text{Voltage drop 2} &= 12.82 \, \Omega \times (10 \, \text{m} / 100 \, \text{m}) \times 0.4 \, \text{A} \\ &= 0.513 \, \text{V} \end{aligned}$$

$$\text{Voltage drop 1} + \text{Voltage drop 2} = 1.354 \, \text{V}$$

A remaining voltage of 3.646 V (5 V – 1.354 V) is the maximum allowable voltage drop between the Central unit and the Distributor 1. The current that flows between the two is 1.6 A.

- Assuming that RG-11/U coaxial cable is used, L1 between the Central unit and the Distributor 1 is calculated by the following equation:

$$\begin{aligned} L1 &= \{ (\text{Voltage drop 1} / \text{Current 1}) / \text{Coaxial cable loop resistance 1 per 100 m} \} \\ &= \{ (3.646 \, \text{V} / 1.6 \, \text{A}) / 2.4 \, \Omega \} \times 100 \, \text{m} \\ &= 94 \, \text{m} \end{aligned}$$

$$\begin{aligned} \text{Maxim cable length L (Length between the Central unit and the Infrared Transmitter/Receiver unit)} \\ &= 94 \, \text{m} + 10 \, \text{m} + 50 \, \text{m} = 154 \, \text{m} \end{aligned}$$

- Assuming that RG-6/U coaxial cable is used, L1 between the Central unit and the Distributor 1 is calculated by the following equation:

$$\begin{aligned} L1 &= \{ (\text{Voltage drop 1} / \text{Current 1}) / \text{Coaxial cable loop resistance 1 per 100 m} \} \\ &= \{ (3.646 \, \text{V} / 1.6 \, \text{A}) / 12.82 \, \Omega \} \times 100 \, \text{m} \\ &= 17 \, \text{m} \end{aligned}$$

$$\begin{aligned} \text{Maxim cable length L (Length between the Central unit and the Infrared Transmitter/Receiver unit)} \\ &= 17 \, \text{m} + 10 \, \text{m} + 50 \, \text{m} = 77 \, \text{m} \end{aligned}$$

Similarly calculated for other types of coaxial cables, the maximum cable length between the Central unit and the Infrared Transmitter/Receiver unit is found in the following table.

RG-59/U	73 m
RG-6/U	77 m
RG-11/U	154 m

The table below shows the required maximum cable length for the example 4, the shorter length of the calculation results (1) and (2) above.

RG-59/U	73 m
RG-6/U	77 m
RG-11/U	114 m

## 16. IF A FAILURE IS DETECTED

### 16.1. Chairman Unit TS-801 and Delegate Unit TS-802

Symptom	Cause and Points to Check	Remedy
Cannot turn ON power.	(When using the lithium-ion battery) Battery not charged.	Batteries are not charged as shipped from the factory. Be sure to fully charge the battery before use. (Refer to p. 42.)
	(When using the AC adapter) Power cord or DC input plug not connected.	Connect the power cord (supplied with the AC adapter) and the DC input plug correctly. (Refer to p. 43.)
No sound output from the speaker or headphones.	Monitor volume control not correctly adjusted.	Adjust the volume to an appropriate level.
	Headphone plug not fully inserted.	Insert the headphone plug fully into the jack.
Cannot initiate speech.	Is the Central Unit's rear panel-mounted Short Circuit indicator illuminated?	Check the cable connected to the Central Unit's Infrared Transmitter/Receiver unit I/O terminals.
	Does the Live Status indicator on the Infrared Transmitter/Receiver unit remain dark?	
Cannot operate the Talk key.	Unit address numbers outside range of 001 – 064.	Set the unit address number within the range of 001 – 064. (Refer to p. 40.)
	Infrared Emitter/Detector exposed to direct sunlight or spotlight.	Reposition in a location not exposed to direct light. (Refer to p. 26.)
	Are the Infrared Transmitter/Receiver units and Chairman/Delegate units positioned to permit their infrared emitter/detector sections to be in sight of each other? Are the TS-905 or TS-907 Infrared Transmitter/Receiver units correctly selected to match the ceiling height and installed so that all the Chairman/Delegate units are in the communications service area? (If both the Power and Speech indicators simultaneously flash, this indicates the unit is out of the communications service area.)	Install all the units so that they are in clear view of each other, and select and install the Infrared Transmitter/Receiver units correctly for the ceiling height. (Refer to p. 24.)
	Cable between the Infrared Transmitter/Receiver unit and the Central Unit not connected.	Connect the cable.
	Priority speech is in progress.	Operate the key after the priority speech is completed.
	Indicator on the microphone extinguishes during speech.	Mic-Off function set to ON.
Microphone indicator flashes.	Battery voltage has dropped below a marginal level.	Replace the battery with a fully charged one.

Symptom	Cause and Points to Check	Remedy
Chime does not sound when the Priority Speech key is pressed.	Central unit's rear panel-mounted Priority Chime volume control is set to the minimum volume position.	Adjust the volume control to an appropriate level.
	The Priority chime mute switch in the Chairman unit's bottom is set to ON.	Set the Priority chime mute switch to OFF.
Mic-Off function does not work.	High background noise level generated by such equipment as air conditioners.	In areas where the background noise level is high, the Mic-Off function may not work. Reposition in a low-noise location or turn off the Mic-Off function.
Battery can be used only for a short period of time.	Not fully charged.	Charging is completed within 5 hours. <b>Note:</b> Fully charged batteries can be used for up to 10 hours. (Refer to p. 42.)
	Battery is approaching the end of its life.	Use a brand-new battery. <b>Note:</b> Battery can be recharged almost 300 times.

## 16.2. Central Unit TS-800

Symptom	Cause and Points to Check	Remedy
Cannot switch ON the power.	Power cord or DC plug not connected.	Correctly connect the power cord and DC plug supplied with the Central unit. (Refer to p. 23.)

## 16.3. Battery Charger BC-900

Symptom	Cause and Points to Check	Remedy
Power indicator (green) does not light even if the power switch is turned ON.	AC plug is not inserted into the wall AC outlet.	Insert the AC plug to the wall AC outlet.
	Fuse has blown.	The fuse must be replaced. For replacement, consult your TOA dealer.
Charging status indicator (red) does not light even if the lithium-ion battery is inserted into its receptacle.	Is the lithium-ion battery correctly inserted into its receptacle?	Insert the lithium ion battery fully into its receptacle.
	Charging terminals are dirty.	Wipe the terminals with a dry cotton swab to clean them.
Short battery recharge duration.	Deterioration of the lithium-ion battery.	Replace with a brand-new BP-900 Lithium-Ion Battery.

## 17. SPECIFICATIONS

### 17.1. Central Unit TS-800

Power Source	100 – 240 V AC, 50/60 Hz (supplied from the supplied AC adapter)
Power Consumption	72 W
Current Consumption	Max. 3 A DC (when 24 V DC is supplied from the supplied AC adapter)
Carrier Frequency	Reception: Audio channel 1: 7.35 MHz Audio channel 2: 8.10 MHz Audio channel 3: 8.55 MHz Audio channel 4: 9.15 MHz Control channel: 6.45 MHz Transmission: Audio channel: 1.95 MHz
Input	MIC: –60 dB*, 600 Ω, unbalanced, ø6.3 mm phone jack (2P) AUX: –20 dB*, 10 kΩ, unbalanced, ø6.3 mm phone jack (2P)
Output	REC: –20 dB*, 10 kΩ, unbalanced, ø6.3 mm phone jack (2P), RCA pin jack HEADPHONES: ø3.5 mm mini jack (3P: monaural)
Number of Connectable Chairman/Delegate Units	64 units
Number of Connectable Infrared Transmitter/Receiver Units	Up to 4 units (with the use of distributor, up to 16 units connectable when they are all TS-905, and up to 12 units when they are all TS-907)
Infrared Transmitter/Receiver I/O Terminal	BNC jack
External Control Terminal	D-sub connector (9P, male)
LED Indicator	Audio signal receiving indicators 1 – 4 CH, Data signal receiving indicator, External control priority indicator, External control communication indicator, Power indicator, Battery indicator (flashes when a Chairman/Delegate unit's battery nears complete discharge)
Function Switch	Simultaneous speaker No. setting switch: 1/2/4 Mic-off setting switch: TIME OUT ON/OFF Speech priority selector switch: A/B/C (A: First-in-first-out priority, B: Last-in-first-out priority, C: Fixed for the first unit, and last-in-first-out for the subsequent units)
Operating Temperature	0 to 40 °C (32 to 104 °F)
Operating Humidity	90 %RH or less (no condensation)
Finish	Panel: Surface-treated steel plate, gray metallic, paint, semi-gloss
Dimensions	359 (w) x 118.8 (h) x 179.8 (d) mm (14.13" x 4.68" x 7.08")
Weight	2.7 kg (5.95 lb)

\* 0 dB = 1 V

**Note:** The design and specifications are subject to change without notice for improvement.

#### • Accessory

AC adapter (DC cord: 1.8 m or 5.91 ft, Detachable AC cord: 2 m or 6.56 ft) ..... 1



## 17.2. Chairman Unit TS-801, Delegate Unit TS-802

Model No.	TS-801	TS-802
Power Source	7.4 V DC (battery), 9 V DC (AC adapter) (supplied from BP-900 battery or AD-0910 AC adapter)	
Current Consumption	Max. 270 mA	
Infrared Emitter/Detector	Wavelength	870 nm (AM: Brightness modulation)
	Modulation Method	Frequency modulation
	Carrier Frequency	Transmission: Audio channel 1: 7.35 MHz Audio channel 2: 8.10 MHz Audio channel 3: 8.55 MHz Audio channel 4: 9.15 MHz Control channel: 6.45 MHz Reception: Audio channel: 1.95 MHz
	Acceptance Angle	Vertical: 90°, Horizontal: 120°
	Emission Angle	Vertical: 90°, Horizontal: 120°
	Covering Range	7 m or 22.97 ft (radius)
	Input	Microphone terminal: XLR-4-31 type (dedicated for connecting the optional TS-903 or TS-904)
Output	Monitor speaker: 8 Ω, 0.2 W Headphones: ø3.5 mm mini jack (3P: monaural) x 2	
LED Indicator	Speech indicator (flashes when the unit is out of communications range), Power indicator (flashes when the unit is out of communications range or when the battery level is low)	
Function	Monitor volume control Headphone volume control Priority speech function	Monitor volume control Headphone volume control
Battery Life	Approx. 10 hours (when the fully-charged BP-900 battery is used with "During speech" to "Standby" ratio of 1:2)	
Operating Temperature	0 to 40 °C (32 to 104 °F)	
Operating Humidity	90 %RH or less (no condensation)	
Finish	Top Panel: ABS resin, gray metallic, paint, semi-gloss	
Dimensions	210 (w) x 68.6 (h) x 152 (d) mm (8.27" x 2.7" x 5.98")	
Weight	630 g (1.39 lb)	

**Note:** The design and specifications are subject to change without notice for improvement.

## 17.3. Microphone (standard) TS-903, Microphone (long) TS-904

Model No.	TS-903	TS-904
Type	Electret condenser microphone	
Directivity	Unidirectional	
Rated Impedance	1.8 kΩ	
Rated Sensitivity	-37 dB (1 kHz, 0 dB = 1 V/Pa)	
LED Indicator	Speech indicator (ring type)	
Frequency Response	100 Hz – 13 kHz	
Output Connector	XLR-4-32 type	
Operating Temperature	0 to 40 °C (32 to 104 °F)	
Operating Humidity	90 %RH or less (no condensation)	
Finish	Gooseneck: Stainless steel, black Other: ABS resin, black	
Length	368 mm (1.21 ft)	518 mm (1.7 ft)
Weight	90 g (0.2 lb)	105 g (0.23 lb)
Applicable Unit (Option)	Chairman unit: TS-801, Delegate unit: TS-802	

**Note:** The design and specifications are subject to change without notice for improvement.

## 17.4. Infrared Transmitter/Receiver TS-905, TS-907

Model No.	TS-905	TS-907	
Power Source	24 V DC (supplied from the optional TS-800)		
Current Consumption	Max. 150 mA	Max. 180 mA	
Infrared Emitter/Detector	Wavelength 870 nm (AM: Brightness modulation)		
	Modulation Method Frequency modulation		
	Carrier Frequency Transmission: Audio channel 1: 7.35 MHz Audio channel 2: 8.10 MHz Audio channel 3: 8.55 MHz Audio channel 4: 9.15 MHz Control channel: 6.45 MHz Reception: Audio channel: 1.95 MHz		
	Acceptance Angle	Vertical: 150°(75°+75°), Horizontal: 360°	Vertical: 90°(45°+45°), Horizontal: 360°
	Emission Angle	Vertical: 150°(75°+75°), Horizontal: 360°	Vertical: 90°(45°+45°), Horizontal: 360°
	Communication Area	Approx. 6 – 7 m (19.69 – 22.97 ft) in radius from the point underneath the unit (Ceiling height: 2.5 – 4.5 m or 8.2 – 14.76 ft)	Approx. 6 m (19.69 ft) in radius from the point underneath the unit (Ceiling height: 5 – 7 m or 16.4 – 22.97 ft)
	Connection Terminal	BNC jack	
LED Indicator	Power		
Operating Temperature	0 to 40 °C (32 to 104 °F)		
Operating Humidity	90 %RH or less (no condensation)		
Finish	Dome: PC resin, visible light cut filter Base: ABS resin, black		
Dimensions	ø120 x 71.3 (h) mm (ø4.72" x 2.81")		
Weight	230 g or 0.51 lb (unit only)		

**Note:** The design and specifications are subject to change without notice for improvement.

### • Accessories

Mounting bracket .....	1
Stand mounting bracket .....	1
Screw M3 x 6 .....	3
U5/16 – NS5/8 thread adapter (except for TS-905 CE version) .....	1

## 17.5. Lithium-Ion Battery BP-900

Nominal Voltage	7.4 V DC
Nominal Capacity	1700 mAh
Operating Temperature	0 to 40 °C (32 to 104 °F)
Operating Humidity	90 %RH or less (no condensation)
Dimensions	71.6 (w) x 20.4 (h) x 37.6 (d) mm (2.82" x 0.8" x 1.48")
Weight	95 g (0.21 lb)

**Note:** The design and specifications are subject to change without notice for improvement.

### • Accessory

Terminal protection cover (pre-installed at the factory) .....	1
----------------------------------------------------------------	---

## 17.6. Battery Charger BC-900

Power Source	100 – 240 V AC, 50/60 Hz (use of the supplied AC adapter)
Current Consumption	Max. 5 A DC
Charging Time	Approx. 5 hours
Charging Capacity	8 BP-900 batteries (optional)
LED Indicator	Charging status (Green: Full charge, Red: On charge), Power indicator
Operating Temperature	0 to 40 °C (32 to 104 °F)
Operating Humidity	90 %RH or less (no condensation)
Finish	Case: Steel, black, paint Battery receptacles: PPO resin, black
Dimensions	240 (w) x 70 (h) x 115 (d) mm (9.45" x 2.76" x 4.53")
Weight	Unit: 1.2 kg (2.65 lb), AC adapter: 520 g (1.15 lb)

**Note:** The design and specifications are subject to change without notice for improvement.

### • Accessory

AC adapter (DC cord: 1.8 m or 5.91 ft, Detachable AC cord: 2 m or 6.56 ft) ..... 1

## 17.7. AC Adapter AD-0910

Power Source	100 – 240 V AC, 50/60 Hz
Output	9 V DC, 1 A
Ripple Voltage	100 mV (p-p)
Current Consumption	400 mA AC, Input 100 V
Cord Length	1.8 m (5.91 ft)
Plug	RC6705, center "+"
Operating Temperature	0 to 40 °C (32 to 104 °F)
Operating Humidity	90 %RH or less (no condensation)
Finish	Case: PC/ABS alloy, black
Dimensions	47.4 (w) x 33 (h) x 86.5 (d) mm or 1.87" x 1.3" x 3.41" (excluding a power cord)
Weight	190 g (0.42 lb)

**Note:** The design and specifications are subject to change without notice for improvement.

### • Accessory

AC power cord (2 m or 6.56 ft) ..... 1

## 17.8. Distributor YW-1022 (2-branch distributor), YW-1024 (4-branch distributor)

Model No.	YW-1022	YW-1024
Frequency Range	1.6 – 1000 MHz (excluding 50 – 70 MHz)	
Distribution Loss	4.5 dB $\pm$ 3 dB (between the Mixing and each Distribution terminals)	8.5 dB $\pm$ 3 dB (between the Mixing and each Distribution terminals)
Input/Output Impedance	75 $\Omega$	
Coaxial Connector	Mixing terminal: BNC jack, power passing type (30 V DC or less, 2 A or less) Distribution 1 and 2 terminals: BNC jack, power passing type (30 V DC or less, 1 A or less)	Mixing terminal: BNC jack, power passing type (30 V DC or less, 2 A or less) Distribution 1 – 4 terminals: BNC jack, power passing type (30 V DC or less, 1 A or less)
Operating Temperature	–10 to +50°C (14 to 122 °F)	
Operating Humidity	90 %RH or less (no condensation)	
Finish	ABS resin, gray	
Dimensions	75 (w) x 122 (h) x 34 (d) mm (2.95" x 4.8" x 1.34")	
Weight	105 g (0.23 lb)	120 g (0.26 lb)

**Note:** The design and specifications are subject to change without notice for improvement.

### • Accessories

Wood screw 4.1 x 25 (for fixing the unit) ..... 2

## 17.9. Rack Mounting Bracket MB-TS900

Finish	Surface-treated steel plate, gray metallic, paint, semi-gloss
Dimensions	65.5 (w) x 177 (h) x 61 (d) mm (2.58" x 6.97" x 2.4")
Weight	680 g (1.5 lb)

**Note:** The design and specifications are subject to change without notice for improvement.

### • Accessories

Rack mounting screw 5 x 12 ..... 4

Rack mounting washer (for M5) ..... 4

### Traceability Information for Europe

Manufacturer:  
TOA Corporation  
7-2-1, Minatojima-Nakamachi, Chuo-ku, Kobe, Hyogo,  
Japan

Authorized representative:  
TOA Electronics Europe GmbH  
Suederstrasse 282, 20537 Hamburg,  
Germany