



## *ACUO 912 Serie*



# AEV On Air broadcast console

## **Guarantee**

The equipment is warranted for a period of 2 years from the date of invoice (ex-works). The warranty does not cover faults provoked by carelessness, natural causes and parts subject to wear. In addition, the cost of shipment is not covered. The warranty will be voided if the equipment is mishandled.

## **Technical Support**

If you require technical support, contact AEV SERVICE giving a clear and concise account of your specific problem. Quote the serial number of your equipment by referring to the AEV nameplate attached to the equipment itself as this is the most important piece of information to be provided.

Telephone: +39 051 6630904 Fax: +39 051 893605

## **Factory Service and Repairs**

If problems arise while the equipment is being installed, consult this manual and check that the installation is being carried out properly. If the problems still cannot be solved, call the AEV SERVICE Department for further information. If the problem is a minor one we can a telephone call will probably suffice. If, on the other hand, the equipment is to be shipped to AEV for service or repairs.

## **Shipping Instruction**

When shipping the equipment to AEV, use the original package in order to be certain that it will be fully protected during handling. If you need the original package, call us for a new one. If you ship the equipment in a different packing container, take care to provide a double package by interposing padding material between the two containers in order to fully protect the equipment during shipment. The package should be marked "FRAGILE" in red. Remember that the RMA number must be clearly visible on the package. If it is not, the equipment will not be accepted.

**IMPORTANT:** Carefully read this paragraph as it contains important instructions concerning operator safety and directions regarding the installation, operation and maintenance of the equipment.

Failure to observe the safety instructions and information given in this manual **constitutes an infringement of the safety rules and design specifications provided for this piece of equipment.**

**AEV Broadcast Srl declines all responsibility** if any one of the safety rules given here in is not observed.

**AEV Broadcast Srl declines all responsibility** if the end-user resells the product.

The equipment is to be used by people capable of operating it in a trouble-free manner and **it is assumed that they are aware of the following safety rules.**

- Keep this manual with the utmost care and close at hand so that it can be consulted whenever needed
- After unpacking the equipment, check it for condition.
- Avoid banging the equipment.
- The packing material (plastic bags, polystyrene, nails, etc.) must never be left within the reach of the children, as **these items are potential sources of danger.**
- Do not use the equipment in places where the temperature is not within the recommended range, as specified by the manufacturer.
- Before connecting the equipment, make sure the nameplate specifications correspond to the mains electricity supply (the nameplate is located on the equipment enclosure).
- Do not remove the sticker from the equipment as it contains important specifications and the relevant serial number.
- To join the equipment to the mains supply, use the power cord purchased with the equipment.

- The equipment must be used only for the purpose it was designed for.
- Abuse or misuse of the equipment is **extremely dangerous** for people, pets and property. The manufacturer declines all responsibility for damage and injury resulting from **improper use** and **mishandling**.
- Certain basic safety rules must be observed when using electrical equipment, in particular: - Never touch the equipment with wet and/or damp hands or other parts of the body.
  - Keep the equipment away from drops of water or sprinkling systems.
  - Never use the equipment near high heat sources or explosive material.
  - Do not introduce any extraneous matter into the equipment.
  - Do not allow children or untrained people to use the equipment.
- Before cleaning or servicing the equipment outside, disconnect it from the supply and wait at least 2 seconds before working on it, as recommended by current safety regulations.
- In the event of faults and/or improper operation, turn off the equipment, shut off the electrical power and call your dealer.
- Do not attempt to make repairs and/or adjustments when covers/guards or circuit boards are to be removed.
- Blown fuses inside the power supply indicate that there may be a fault in the power supply itself. The fuses must be replaced by qualified and authorised persons. It is advisable to call your nearest dealer.
- Call your dealer for any repairs and be certain original spare parts are used.

**Failure to observe this rule may adversely affect the safety level of your equipment.**

- The equipment is to be connected to the mains supply and provided with adequate and efficient earth conductors.
- The electrical wiring must be done in compliance with current electrical codes CEI 64-8 "Electrical specification for domestic buildings".
- When installing, leave a clearance of at least 1 cm around the equipment to allow air to pass freely.

**NOTE. This piece of equipment has been manufactured to the highest standards of workmanship. It must be used properly and serviced as recommended to ensure long-term dependable operation.**

The installation must be done in order to be able to guarantee an easy access to the cable of feeding.

The device of dissection of the equipment is the cable of feeding, so it must be unconnected from the equipment every time it is necessary to do any type of maintenance.



## Contents

|   |    |
|---|----|
| Guarantee.....                              | 2  |
| Technical Support .....                     | 2  |
| Factory Service and Repairs .....           | 2  |
| Shipping Instruction .....                  | 2  |
| Precautions .....                           | 3  |
| Contents .....                              | 4  |
| Features .....                              | 5  |
| Input functions and channels .....          | 5  |
| Input channel configuration .....           | 5  |
| Outputs .....                               | 6  |
| External controls .....                     | 5  |
| Monitoring .....                            | 5  |
| Input configuration .....                   | 5  |
| Input setting .....                         | 5  |
| Master outputs.....                         | 6  |
| External control.....                       | 6  |
| Monitoring .....                            | 6  |
| Micro - Line channel .....                  | 7  |
| Digital - Line Module .....                 | 8  |
| USB - Line Module .....                     | 9  |
| Monitoring section .....                    | 10 |
| Telephone hybrid section .....              | 10 |
| Control Room & Control Studio section ..... | 11 |
| Master setup section .....                  | 11 |
| Rear Panel – Connections .....              | 12 |
| RJ connectors pin out .....                 | 14 |
| Logic GPI/O port .....                      | 15 |
| Telephone hybrids – Telco.....              | 18 |
| Remote fader ACUO Serie.....                | 19 |
| Technical specifications .....              | 20 |

## Features

### audio inputs:

12 double-channels + 2 telephone hybrids  
balanced Micro and line inputs, digital AES/EBU, USB audio I/O interface, TELCO I/O

### Faders:

Faders (100 mm) with A/B input selector, 3 bands tones control on each input.

## Input functions and channels

- Six Microphone inputs ( MIC1,...,MIC6 )
- Twelve stereo balanced line inputs ( LIN1,.....LIN12 )
- Four digital AES/EBU input ( DIG1, DIG2, DIG3, DIG4 )
- Two USB audio inputs ( USB1, USB2 )
- Two telephone hybrid/TELCO ( TEL1, TEL2 )

## Input channels configuration:

Channel 1 : MIC1 / LINE 1  
Channel 2 : MIC2 / LINE 2  
Channel 3 : MIC3 / LINE 3  
Channel 4 : MIC4 / LINE 4  
Channel 5 : MIC5 / LINE 5  
Channel 6 : MIC6 / LINE 6  
Channel 7 : DIG1 / LINE 7  
Channel 8 : DIG2 / LINE 8  
Channel 9 : DIG3 / LINE 9  
Channel 10 : DIG4 / LINE10  
Channel 11 : USB1 / LINE11  
Channel 12 : USB2 / LINE12

## Input setting

All settings are independent for each input, via encoder.

Channel setting:

- Gain / Level adjustment -12÷+12 dB
- Input balance -12÷+12 dB
- tone equalizer High, Medium , Low -14÷+14 dB
- Private tel OFF/ON
- Control Studio OFF/ON
- PGM assignement SPEECH/MUSIC
- C. Room Mute OFF/ON
- ST MU OFF/ON
- Tally OFF/ON
- Talk back on C.Studio OFF/ON
- Line mono (only for Micro inputs) OFF/ON
- Phantom Power (only for Micro inputs) OFF/ON

Also you can to select the Bus assignment pushing the following buttons:

- PGM
- UTL
- AUX
- CUE

**Master Outputs**

- PGM:** Analog balanced stereo with XLR connectors
- UTL:** Analog balanced stereo with RJ45 connector
- AUX:** Analog balanced stereo with RJ45 connector
- PGM Dig:** digital AES/EBU stereo with RJ45 connector
- UTL Dig:** digital AES/EBU stereo with RJ45 connector

**Auxiliary outputs**

- Control Room:** Analog balanced stereo with RJ45 connector
- Control Studio:** Analog balanced stereo with RJ45 connector
- Mute C. Studio:** Analog balanced stereo with RJ45 connector
- Headphone :** Analog stereo with Jack 6,3 mm connector

**Auxiliary input**

- External :** Analog balanced stereo with RJ45 connector

**External controls**

- Remote Fader with logic controls, (START/STOP) with RJ45 connector
- GPI Opto-isolated logic inputs
- GPO Opto-isolated logic outputs

**Monitoring**

- Level control for headphone, Control Room, Control Studio mutable
- External inputs for Monitor
- Headphone with integrated amplifier
- double stereo digital VU-Meter on the TFT display PGM ( fixed ) SEL ( EXT, UTL, AUX )



**Micro - Line channel ( channels 1 – 6 )**

All controls on the Micro-Line input channel are described below.

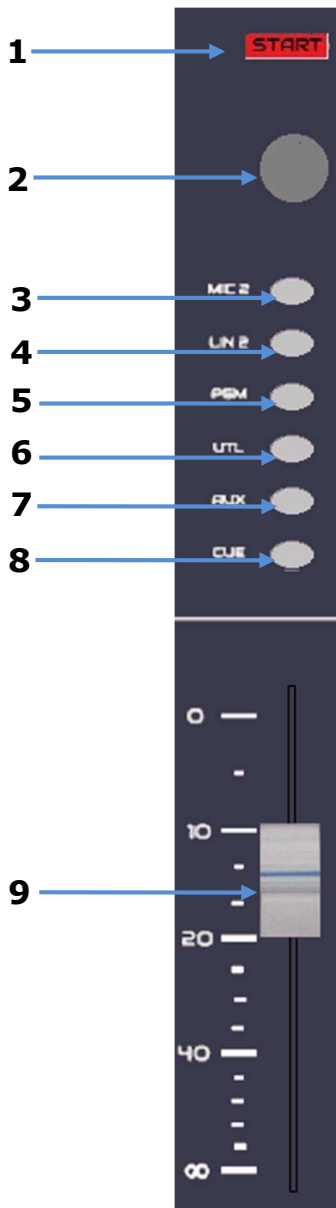

- 1** – START lamp, it lights when the channel fader is active
- 2** – knob jog ; directly it select the Gain input level the range is -12 ÷ +12 dB;  
in sequence, the following commands:  
1th push-button Balance adjust (-12 ÷ +12 dB)  
2th push-button Treble band adjust (-14 ÷ +14 dB)  
3th push-button Middle band adjust (-14 ÷ +14 dB)  
4th push-button Bass band adjust (-14 ÷ +14 dB)  
5th push-button Private Tel active (OFF/ON)  
6th push-button TB Studio to C.Room active (OFF/ON)  
7th push-button PGM bus selection ( Speech/ Music)  
8th push-button Control Room Mute active (OFF/ON)  
9th push-button Mute C.Studio active (OFF/ON)  
10th push-button Tally active (OFF/ON)  
11th push-button TB Regia to C. Studio active (OFF/ON)  
12th push-button Phantom power for the condenser microphone active ( OFF/ON )  
13th push-button Micro or LineMono selection ( OFF/ON )
- 3** – MIC Button to activate the microphone source (only with the channel in STOP)
- 4** – LINE Button n to activate the line source (only with the channel in STOP)
- 5** – PGM Button for routing the channel to the PGM bus.
- 6** – UTL Button for routing the channel to the UTL bus.
- 7** – AUX Button for routing the channel to the AUX bus.
- 8** - Button enabling the preview CUE.
- 9** - Fader.



## Dig - Line Module ( channels 7 – 10 )

All controls on the Dig-Line input channel are described below.

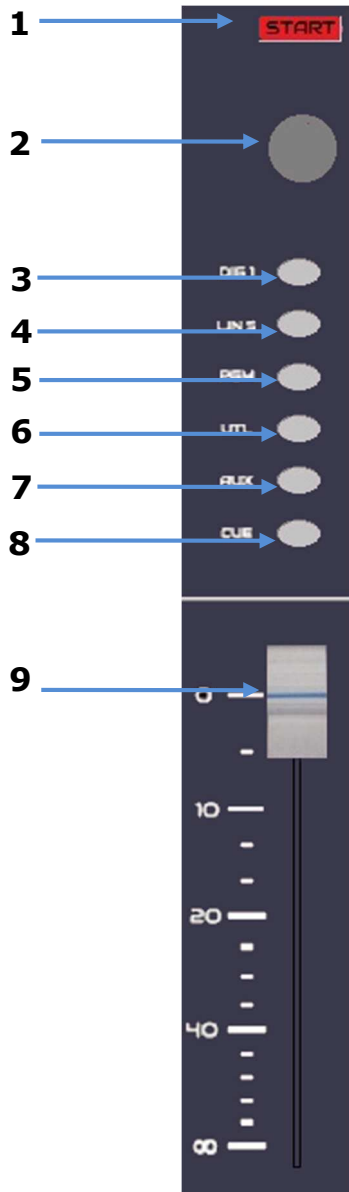

- 1** - START lamp, it lights when the channel fader is active
- 2** - knob jog ; directly it select the Gain input level the range is -12 ÷ +12 dB;

in sequence, the following commands:

- 1th push-button Balance adjust (-12 ÷ +12 dB)
- 2th push-button Treble band adjust (-14 ÷ +14 dB)
- 3th push-button Middle band adjust (-14 ÷ +14 dB)
- 4th push-button Bass band adjust (-14 ÷ +14 dB)
- 5th push-button Private Tel active (OFF/ON)
- 6th push-button TB Studio to C.Room active (OFF/ON)
- 7th push-button PGM bus selection ( Speech/ Music)
- 8th push-button Control Room Mute active (OFF/ON)
- 9th push-button Mute C.Studio active (OFF/ON)
- 10th push-button Tally active (OFF/ON)
- 11th push-button TB Regia to C. Studio active (OFF/ON)

**3** - DIG to activate the digital AES/EBU source (only with the channel in STOP)

**4** - LINE to activate the line source (only with the channel in STOP)

**5** - PGM Button for routing the channel to the PGM bus.

**6** - UTL Button for routing the channel to the UTL bus.

**7** - AUX Button for routing the channel to the AUX bus.

**8** - Button enabling the preview CUE.

**9** - Fader.



## USB - Line Module ( channels 11 – 12 )

All controls on the USB-Line input channel are described below.

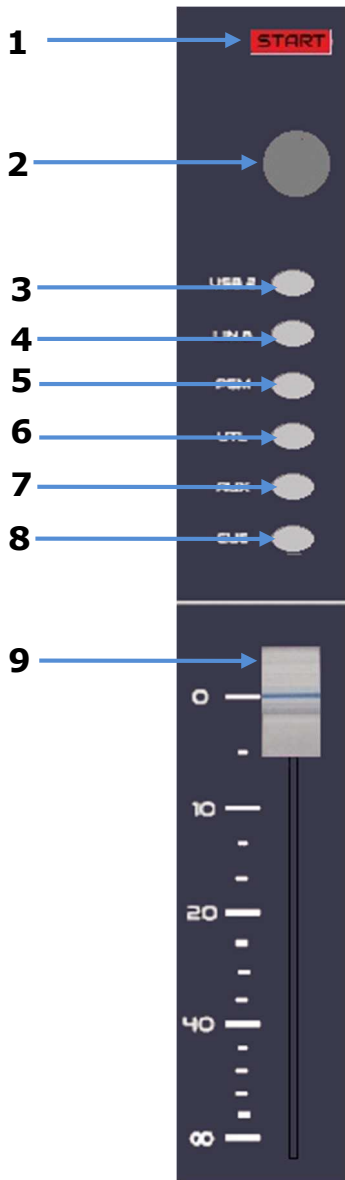

**1** – START lamp, it lights when the channel fader is active

**2** – knob jog ; directly it select the Gain input level the range is -12 ÷ +12 dB;

in sequence, the following commands:

1th push-button Balance adjust (-12 ÷ +12 dB)

2th push-button Treble band adjust (-14 ÷ +14 dB)

3th push-button Middle band adjust (-14 ÷ +14 dB)

4th push-button Bass band adjust (-14 ÷ +14 dB)

5th push-button Private Tel active (OFF/ON)

6th push-button TB Studio to C.Room active (OFF/ON)

7th push-button PGM bus selection ( Speech/ Music)

8th push-button Control Room Mute active (OFF/ON)

9th push-button Mute C.Studio active (OFF/ON)

10th push-button Tally active (OFF/ON)

11th push-button TB Regia to C. Studio active (OFF/ON)

**3** – USB to activate the digital usb source (only with the channel in STOP)

**4** – LINE to activate the line source (only with the channel in STOP)

**5** – PGM Button for routing the channel to the PGM bus.

**6** – UTL Button for routing the channel to the UTL bus.

**7** – AUX Button for routing the channel to the AUX bus.

**8** - Button enabling the preview CUE.

**9** - Fader.

**Monitoring section**

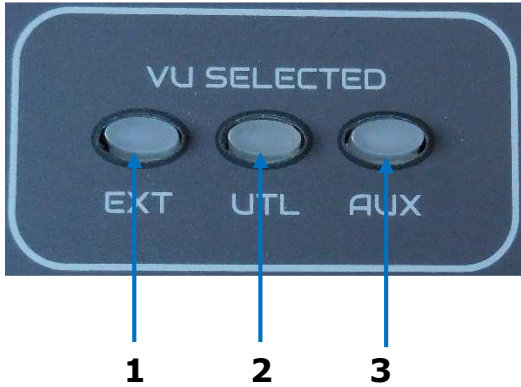

**1** - Button for selecting the EXT input on Switched digital VUMeters.

**2** - Button for selecting the Master UTL output on Switched digital VU-Meters.

**3** - Button for selecting the Master AUX output on Switched digital VU-Meters.

**Telephone/TELCO hybrids section**

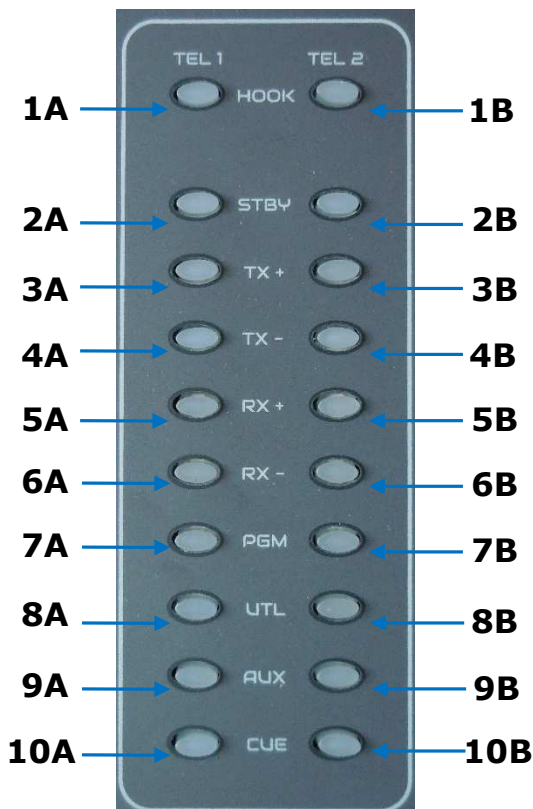

**1A** - HOOK button for telephone line 1 hook-up.  
**1B** - HOOK button for telephone line 2 hook-up.

**2A** - Button for Stanby state for telephone line 1.  
**2B** - Button for Stanby state for telephone line 2.

**3A** - Button for TX+ adjust for telephone line 1.  
**3B** - Button for TX+ adjust for telephone line 2.

**4A** - Button for TX- adjust for telephone line 1.  
**4B** - Button for TX- adjust for telephone line 2.

**5A** - Button for RX+ adjust for telephone line 1.  
**5B** - Button for RX+ adjust for telephone line 2.

**6A** - Button for RX- adjust for telephone line 1.  
**6B** - Button for RX- adjust for telephone line 2.

**7A** - Button for assigning the tel1 to the PGM bus.  
**7B** - Button for assigning the tel2 to the PGM bus.

**8A** - Button for assigning the tel1 to the UTL bus.  
**8B** - Button for assigning the tel2 to the UTL bus.

**9A** - Button for assigning the tel2 to the AUX bus.  
**9B** - Button for assigning the tel2 to the AUX bus.

**10A** -Button for assigning the tel2 to the CUE bus.

**10B** -Button for assigning the tel2 to the CUE bus.

## Room & Studio section

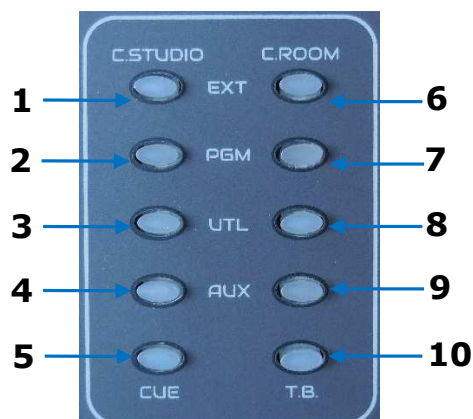

### Control Studio selection

- 1** – Button for selecting the EXT input for routing it to the Control Studio output.
- 2** - Button for selecting the master PGM output for routing it to the Control Studio output.
- 3** - Button for selecting the master UTL output for routing it to the Control Studio output.
- 4** - Button for selecting the master AUX output for routing it to the Control Studio output.
- 5** - Button for selecting the CUE bus for routing it to the Control Studio output.

### Control Room selection

- 6** – Button for selecting the EXT input for routing it to the Control Room outputs.
- 7** - Button for selecting the master PGM output for routing it to the Control Room outputs.
- 8** - Button for selecting the master UTL output for routing it to the Control Room outputs.
- 9** - Button for selecting the master AUX output for routing it to the Control Room outputs.

### Master setup

Master knob jog ; directly it select the Gain headphone level, the range is  $-\infty \div +8$  dB; in sequence, the following commands:

- 1th push-button Control Room level ( $-\infty \div +8$  dB)
- 2th push-button Control Studio level ( $-\infty \div +8$  dB)
- 3th push-button PGM output level ( $-12 \div +12$  dB)
- 4th push-button External input level ( $-12 \div +12$  dB)
- 5th push-button CUE interlock (OFF/ON)
- 6th push-button PGM Digital sample rate ( 32, 44.1, 48, 96 KHz )
- 7th push-button UTL Digital sample rate ( 32, 44.1, 48, 96 KHz )
- 8th push-button channel selection to associate the command I / O Start/Stop A (GPIO 1)
- 9th push-button channel selection to associate the command I / O Start/Stop B (GPIO 2)
- 10th push-button channel selection to associate the command Out Start/Stop

**AEV Broadcast Srl**, via della Tecnica 33 – 40050 Argelato (BO) Italy

**AEV** Web site [www.aev.eu](http://www.aev.eu) e-mail [info@aeV.eu](mailto:info@aeV.eu)

## Talk Back

**10** - Button to active the Talkback function to the Control Studio outputs.

### Talk back Regia to Studio:

When the TB (talk back) button is pressed, the signal of the enabled microphone is sent to the Control Studio output.

- Channel with function talkback to studio (TBST: ON)
- Channel in STOP

What happens:

- the Talk back button of the remote fader lights up
- the previous selection of the Control Studio flashes
- the audio signal present in the Control studio is replaced by the channel selected in TB

### Talk back Studio to Regia :

(need the Remote Fader)

- Channel connected to the Remote Fader unit with talkback function activated (STCR: ON)
- Channel in STOP

What happens when the remote TB (talk back) button is pressed:

- the Talk back button of ACUO flashes
- the previous selection of the Control Room flashes
- the audio signal present in the Control Room is replaced by the channel connected to the Remote Fader unit
- the signal of the enabled microphone is sent to the Control Room output.

**Rear panel – connections**

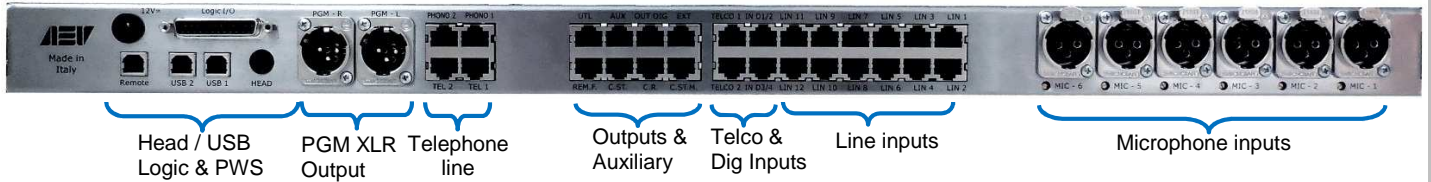

**Microphone inputs connection**

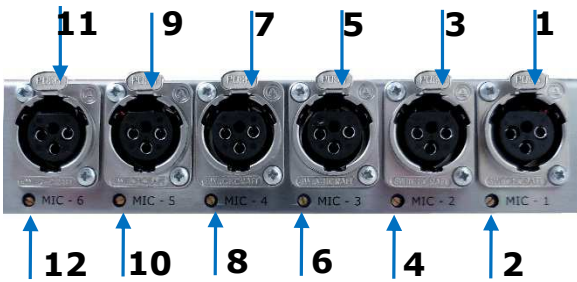

- 1** – Microphone 1 input XLR F connector.
- 2** - Trimmer adjusting the MIC 1 input level from 0 ÷ to +30 dB for very low volume microphones.
- 3** – Microphone 2 input XLR F connector.
- 4** - Trimmer adjusting the MIC 2 input level from 0 ÷ to +30 dB for very low volume microphones.
- 5** – Microphone 3 input XLR F connector.
- 6** - Trimmer adjusting the MIC 3 input level from 0 ÷ to +30 dB for very low volume microphones.
- 7** – Microphone 4 input XLR F connector.
- 8** - Trimmer adjusting the MIC 4 input level from 0 ÷ to +30 dB for very low volume microphones
- 9** – Microphone 5 input XLR F connector.
- 10** - Trimmer adjusting the MIC 3 input level from 0 ÷ to +30 dB for very low volume microphones.
- 11** – Microphone 4 input XLR F connector.
- 12** - Trimmer adjusting the MIC 4 input level from 0 ÷ to +30 dB for very low volume microphones

**Inputs & Telco connection**

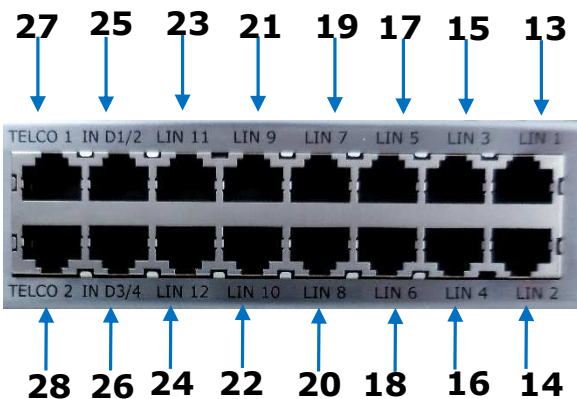

- 13** – Line 1 input RJ45 connector.
- 14** – Line 2 input RJ45 connector.
- 15** – Line 3 input RJ45 connector.
- 16** – Line 4 input RJ45 connector.
- 17** – Line 5 input RJ45 connector.
- 18** – Line 6 input RJ45 connector.
- 19** – Line 7 input RJ45 connector.
- 20** – Line 8 input RJ45 connector.
- 21** – Line 9 input RJ45 connector.
- 22** – Line 10 input RJ45 connector.
- 23** – Line 11 input RJ45 connector.
- 24** – Line 12 input RJ45 connector.
- 25** – Digital 1/2 input RJ45 connector.
- 26** – Digital 3/4 input RJ45 connector.
- 27** – Telco 1 IN/OUT RJ45 connector.
- 28** – Telco 2 IN/OUT RJ45 connector.

**Outputs & Auxiliary connection**

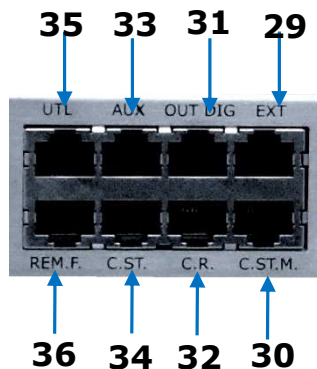

- 29** – External input RG45 connector.
- 30** – Control Studio Mutable output RJ45 connector
- 31** – PGM Dig & UTL Dig2 outputs RG45 connector.
- 32** – Control Room output RJ45 connector.
- 33** – AUX master output RJ45 connector
- 34** – Control Studio output RJ45 connector.
- 35** – UTL master RG45 connector.
- 36** – Remote Fader RG45 connector.

**Telephone connection**

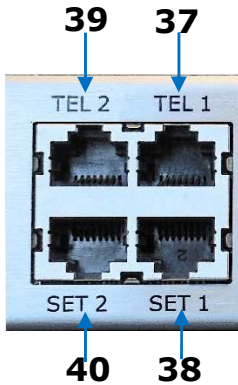

- 37** - Connector RJ45 for telephone line 1.
- 38** - Connector RJ45 for telephone service 1.
- 39** - Connector RJ45 for telephone line 2.
- 40** - Connector RJ45 for telephone service 2.

**Outputs XLR connection**

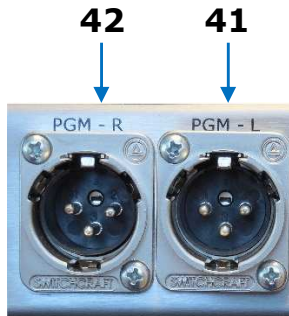

- 41** - PGM left channel XLR connector.
- 42** - PGM right channel XLR connector.

**Head/USB/Logic & PWS connections**

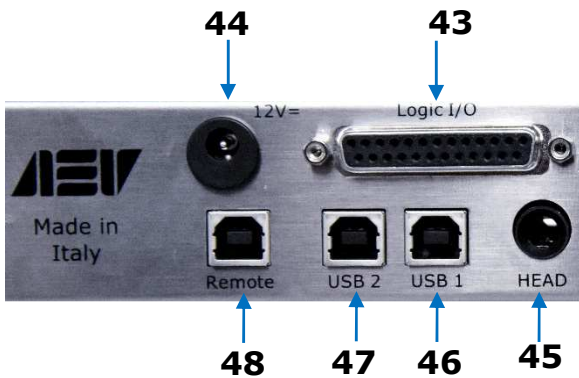

- 43** - Logic I/O DB15 connector.
- 44** - PWS connector.
- 45** - Headphone jack 6,3 mm connector.
- 46** - USB 1 connector.
- 47** - USB 2 connector.
- 48** - USB serial connection.

**pin out RJ45**

**Line in/UTL/AUX/C.Room/C.Studio/Ext**

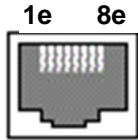

- 1e** - left channel +
- 2e** - left channel -
- 3e** - right channel +
- 4e** - GND
- 5e** - N.C.
- 6e** - right channel -
- 7e** - N.C.
- 8e** - N.C

**Digital Outputs RJ45 pin out**

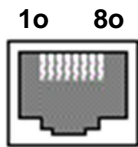

- 1o** - UTL dig +
- 2o** - UTL dig -
- 3o** - PGM dig +
- 4o** - GND
- 5o** - N.C.
- 6o** - PGM dig +
- 7o** - N.C.
- 8o** - N.C.

**Remote fader RJ45 pin out**

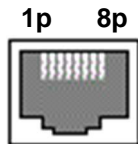

- 1p** - +5v
- 2p** - IN
- 3p** - Start/Stop L
- 4p** - Start/Stop S
- 5p** - Talk Back L
- 6p** - Talk Back S
- 7p** - GND
- 8p** - GND

**Tel line/ tel set RJ45 pin out**

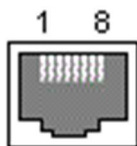

- 1t** - N.C.
- 2t** - N.C.
- 3t** - N.C.
- 4t** - tel set
- 5t** - tel line
- 6t** - N.C.
- 7t** - N.C.
- 8t** - N.C.

**Telco I/O set RJ45 pin out**

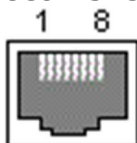

- 1t** - input +
- 2t** - input -
- 3t** - output +
- 4t** - GND
- 5t** - GND
- 6t** - output -
- 7t** - N.C.
- 8t** - telco activation - active low (GND)



**Logic GPI/O port**

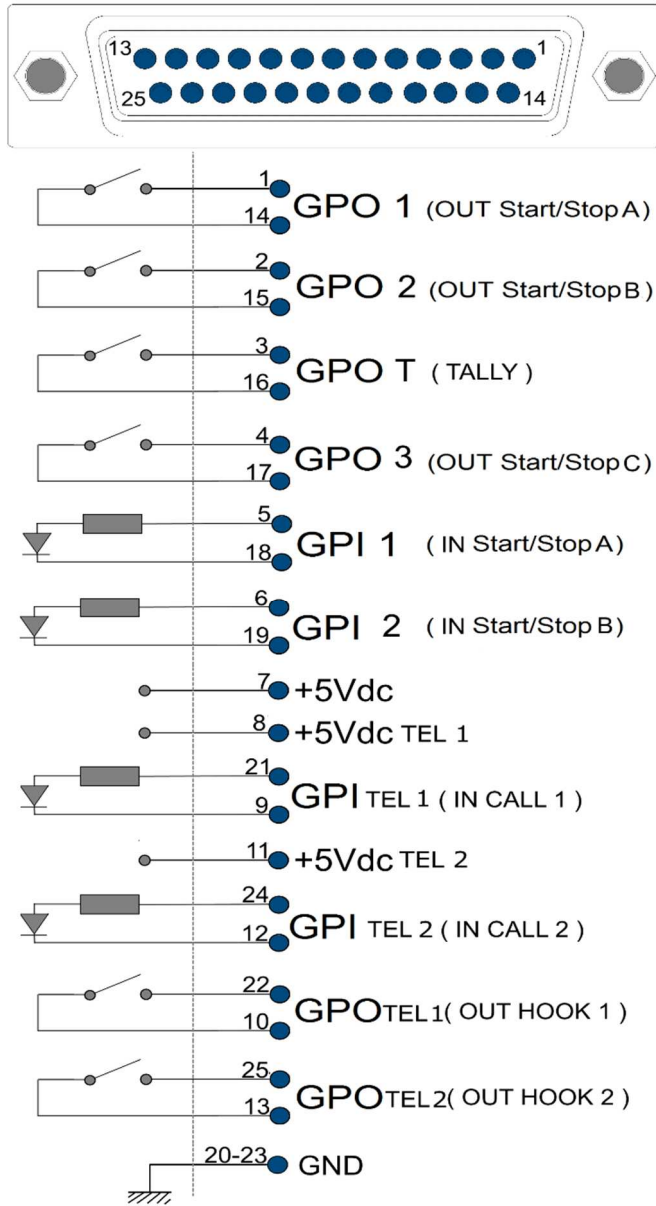

- 1-14** GPO1 Start/Stop A; Start=close, Stop=open with selected channel
- 2-15** GPO2 Start/Stop B; Start=close, Stop=open with selected channel
- 3-16** GPO Tally; (Start)+(Tally ON)
- 4-17** GPO3 ; (Start) with selected channel
- 5-18** GPI1 Start/Stop IN A ; Toggle
- 6-19** GPI2 Start/Stop IN B ; Toggle
- 7** +5V



|               |                  |
|---------------|------------------|
| <b>8</b>      | +5V TEL1         |
| <b>9 -21</b>  | GPI TEL 1 (CALL) |
| <b>11</b>     | +5V TEL2         |
| <b>12 -24</b> | GPI TEL 2 (CALL) |
| <b>10 -22</b> | GPO TEL 1 (HOOK) |
| <b>13 -25</b> | GPO TEL 2 (HOOK) |
| <b>20 -23</b> | GND              |

- **GPO 1 Out ( Start / Stop A )** through the encoder master to the voice GPIO1 (Start / Stop A) select the channel assignment, so when the channel will in Start, the contact between 1 and 14 will close, with the channel in Stop the contact is open .
- **GPO 2 Out ( Start / Stop B )** through the Master encoder select GPIO2 (Start / Stop B) and select the channel assignment, so when the channel will put in Start, the contact between 2 and 15 will close , with the channel put in Stop the contact is open.
- **GPO Tally** : Endcoder in each channel, through the Encoder, to the item TALLY set ON , so closes the contact between pins 3 and 16 will close when the channel is put in Start
- **GPO 3** : Endcoder by the Master, under GPO3 select the channel assignment , so, the contact between pins 4 and 17 will close when the channel will put in Start in, the contact will open when you put in Stop the channel.
- **GPI 1 ( In Start/Stop A )** : through the Master encoder select **GPIO1 (Start/Stop A)** and select the channel assignment, in which way , from the outside, through a circuit to activate the photo - coupler placed between the pins 5 and 13, states Start and Stop will alternate in the channel , the status of which will be remote using the control **Out Start/Stop A**
- **GPI 2 ( In Start/Stop B )** through the Master encoder select **GPIO2 (Start/Stop B)** and select the channel assignment, in which way , from the outside, through a circuit to activate the photo - coupler place between pins 5:13 states will alternate start and stop of the channel , the status of which will be using the remote control **Out Start/Stop A**
- **GPI TEL1 ( In CALL 1 )** from the outside, through a circuit to activate the photo - coupler place between pins 9:21 states will alternate Hook flash botton of the TEL 1 channel, the status of which will be using the remote control **Out Start/Stop A**
- **GPI TEL2 ( In CALL 2 )** from the outside, through a circuit to activate the photo - coupler place between pins 12:24 states will alternate Hook flash botton of the TEL 2 channel, the status of which will be using the remote control **Out Start/Stop A**

Connection START channels to AEV OnAirLight contact:

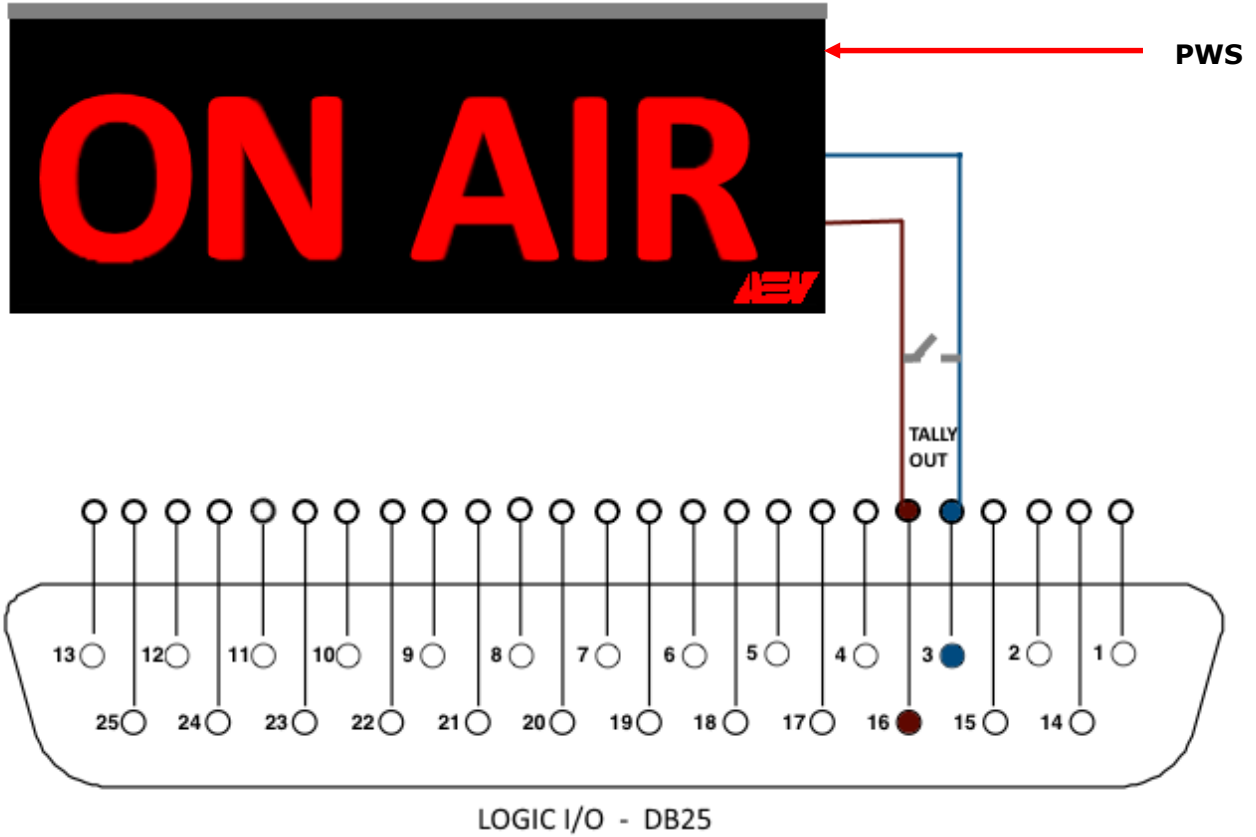

## Telephone hybrids / Telco operations

- Incoming Phone Call: **HOOK** button flashes
- Attach incoming call, press the **HOOK** key (it remains lit)
- Telephone call on hold:
  - button **HOOK** in ON
  - **CUE** (ON) of the bar phone selected
  - **PRIV TEL** (ON) of the microphone channel
  - Regia Microphone in **STOP**
- Meeting function:
  - (**STBY OFF**) enabled on the same bus hybrids **TEL1**, **TEL2** and possibly a channel with microphone
  - to listen to audio on your phone to activate the corresponding bus C. Room (Regia) and / or C.Studio (studio).
  - **PRIV TEL** (ON) of the microphone channel

### TELCO FUNCTION

When the Telco RJ45 adapter is connect, the ACUO CPU recognizes the connection and switches the internal circuit in the Telco function;

- all level signals adjust will be the same of the telephone wired connection: TX+, TX-, RX+, RX-
- In the Logic I/O DB25 port there are also the input & output commands to interface a external telephone hybrid, connecting these commands to the GPIO of the external telephone hybrid you will see the incoming phone call : HOOK button flashes; in order to Attach incoming call, press the HOOK key (it remains lit)

Connection HOOK commands to GPI/O of external telephone hybrid contact:

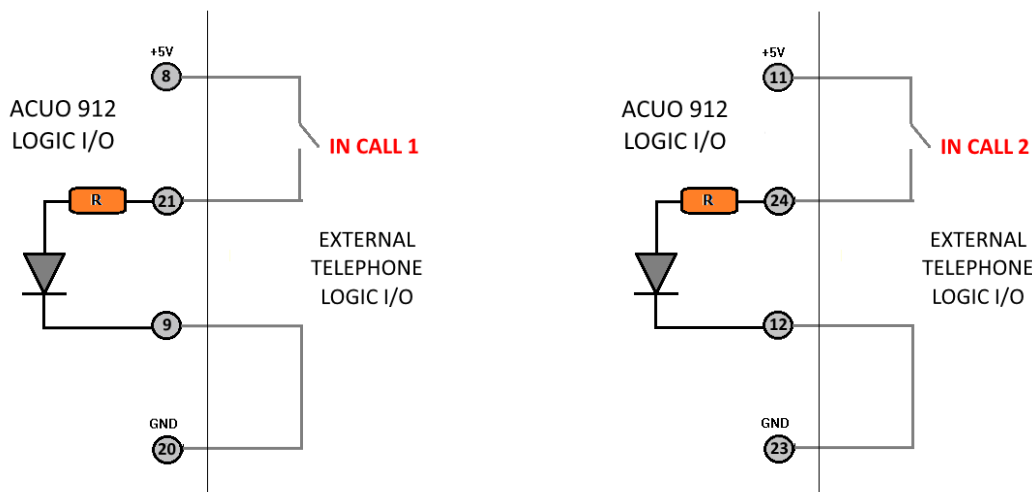

- You can choose the internal bus where you drive the telco audio signal ( PGM, UTL, AUX)

## Remote Fader ACUO serie

In order to optimize the operativity, it is possible to connect the option Remote Fader unit to the console with a simple ethernet cable

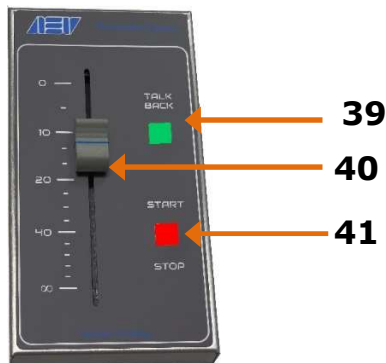

**39** talk Back button Remote Fader

**40** Music slider

**41** START/STOP button

**42** talk Back button on ACUO



With the Remote fader it is possible to command the START/STOP state of the assigned channels, in every channel it is possible to active the assignment in the channel setup:

6th push-button TB Studio to C.Room STCR active (ON)

7th push-button PGM bus selection ( Speech )

With the slider of the Remote Fader (**40**) you can reduce all inputs setted as Music and microphone channels associated (speech) do not change the level.

### Talk back Studio to Regia :

- Channel connected to the Remote Fader unit with talkback function activated (STCR: ON)
- Channel in STOP (**41**)

What happens when the remote TB (talk back) button of the REMOTE Fader unit (**39**) is pressed:

- the Talk back button of ACUO (**42**) flashes
- the previous selection of the Control Room flashes
- the audio signal present in the Control Room is replaced by the channel connected to the Remote Fader unit
- 

### Talk back Regia to Studio:

When the TB (talk back) button in the ACUO console (**42**) is pressed, the signal of the enabled microphone is sent to the Control Studio output.

- Channel with function talkback to studio (TBST: ON)
- Channel in STOP

### What happens:

- the Talk back button of the remote fader lights up (**39**)
- the previous selection of the Control Studio flashes
- the audio signal present in the Control studio is replaced by the channel selected in TB

**TECHNICAL SPECIFICATIONS**
**Microphone Inputs**

|                         |  |
|-------------------------|--|
| Input configuration     | Electronically balanced                      |
| Input Impedance         | 200 Ω  |
| Sensitivity Level Range | Adjustable from -70 ÷ -40 dBu (Trimmer adj.) |
| Input Level Range       | ±12 dBu (Digital adj. step 0,5 dB)           |
| Maximum Input Level     | - 30 dBu                                     |
| Phantom Supply          | 48 Vdc selectable                            |
| 100 mm Fader            | VCA Digital controlled                       |
| Connector               | XLR Female                                   |

**Line Inputs & External Input**

|                      |                                    |
|----------------------|------------------------------------|
| Input configuration  | Electronically balanced            |
| Input Impedance      | 10 K Ω (600 Ω wired)               |
| Input Level Range    | ±12 dBu (Digital adj. step 1,0 dB) |
| Headroom             | + 18 dBu                           |
| 100 mm Fader control | VCA Digital controlled             |
| Connector            | RJ-45                              |

**Digital inputs**

|                      |  |
|----------------------|--|
| Input configuration  | AES/EBU, IEC958,S/PDIF & EIAJ CP340/1201 |
| Sample Rate          | Automatic 32, 44.1, 48, 96 KHz converter |
| 100 mm Fader control | VCA Digital controlled                   |
| Connector            | RJ-45                                    |

**Telephone Hybrid / Telco**

|                     |   |
|---------------------|---|
| Input configuration | Opto-coupled  |
| Input impedance     | 600 Ω Bal   |
| Line Compensation   | Automatically (max 5 Km)                              |
| Tx Level            | ±12 dBu (Digital adj. step 0,5 dB)                    |
| Rx Level Range      | ±12 dBu (Digital adj. step 0,5 dB)                    |
| Frequency response  | 300 Hz ÷ 3400 Hz (-2 dB) ; 300 Hz ÷ 3400 Hz (-1.5 dB) |
| Distortion          | < 1.5 %   |
| Noise               | -60 dB.   |

**Analog Outputs**

|                            |                         |
|----------------------------|-------------------------|
| Output configuration       | Electronically balanced |
| Output Impedance           | 100 Ω                   |
| PGM Output Level Range     | -12 ÷ +12 dBu           |
| Connector                  | XLR male                |
| UTL/AUX Output Level Range | -12 ÷ +12 dBu           |
| Connector                  | RJ-45                   |
| C Room Mut. Output Lev.    | - 12 ÷ +12 dBu          |
| Connector                  | RJ-45                   |

**Digital Outputs**

|                      |  |
|----------------------|--|
| Output configuration | AES/EBU, IEC958,S/PDIF & EIAJ CP340/1201 |
| Sample Rate          | Automatic 32, 44.1, 48, 96 KHz converter |
| Connector            | RJ-45                                    |

**Headphones**

|                    |                                     |
|--------------------|-------------------------------------|
| configuration Type | Stereo unbalanced (C.Room no Muted) |
| Output Impedance   | 50 Ω                                |
| Connector          | JACK 6,3 mm                         |

**Logic I/O**

|                   |                                 |
|-------------------|---------------------------------|
| Configuration     | Optic solid state relay         |
| Max Voltage       | 50 Vdc/ac                       |
| Max Current       | 100 mA                          |
| Connector         | DSUB 25 pole female             |
| USB Port          | 2 x USB 2.0 interface           |
| <b>Dimensions</b> | 690 x 360 x 44 mm ( L x D x H ) |