

## Professional Powered Speakers

# EUROLIVE B115D/B112D

### Active 1000-Watt 2-Way 15"/12" PA Speaker System with Wireless Option and Integrated Mixer

- High-power 2-way PA sound reinforcement speaker system for live and playback applications
- Ultra-compact and lightweight system delivers excellent sound even at extreme sound pressure levels
- "Wireless-ready" for high-quality BEHRINGER digital wireless system (not included)
- 2-channel mixer with individual Mic/Line inputs, Volume controls and Clip LEDs
- Dedicated 2-band EQ plus integrated sound processor for ultimate system control and speaker protection
- Revolutionary Class-D amplifier technology: enormous power, incredible sonic performance and super-light weight
- Extremely powerful 15"/12" long-excursion driver provides incredibly deep bass and acoustic power
- State-of-the-art 1.35" aluminum-diaphragm compression driver for exceptional high-frequency reproduction
- Ultra-wide dispersion, large-format exponential horn
- Additional Line output allows linking of additional speaker systems
- Versatile trapezoidal enclosure design allows different positioning:
  - Stand mounting with 35-mm pole socket
  - Tilts on its side for use as a floor monitor



EUROLIVE B115D and B112D active loudspeakers are exactly what you've come to expect from BEHRINGER—more power, more features and absolutely more affordable! Our engineers have really outdone themselves, creating two self-contained PA solutions that merge state-of-the-art, 1,000-Watt Class-D power amp technology, built-in wireless microphone capability and exceptional portability. These professional active loudspeakers are destined to become legends in its own right, alongside the other EUROLIVE models that have made BEHRINGER the world leader in active loudspeakers.

### Cut the Fat; Keep the Beef

We drew from our considerable experience to build these performance-grade loudspeakers and made them lighter (B115D: 38.6 lbs./17.5 kg; B112D: 32 lbs./14.5 kg) and more powerful. We started with custom-engineered Class-D power amps for the ultimate in low-distortion power and efficiency. Backed by SMPS (Switch Mode Power Supply) technology, the high-tech alternative to heavy transformers and massive heat sinks, these loudspeakers can run cool all day and all night without even breaking a sweat!

*Continued on next page*



# EUROLIVE B115D/B112D

- Ergonomically shaped handles for easy carrying and setup
- High-quality components and exceptionally rugged construction ensure long life
- Conceived and designed by BEHRINGER Germany

## Wireless Wonderland

Until now, adding wireless microphones to a PA system meant either a mess of wires and dangling receivers or worse, a built-in receiver with dodgy performance and a hefty price tag. Those days are officially over thanks to BEHRINGER ULTRALINK Series wireless mics that feature our exclusive, ultra-compact 2-channel receiver. Just plug the receiver into the dedicated wireless port on the rear panel and you have full access to two channels of supremely stable, natural-sounding wireless connectivity. Sold separately and available in hand-held or headset models, BEHRINGER ULTRALINK Series wireless mics will immediately (and inexpensively) expand your B115D/B112D to handle virtually any live sound application.

## Built-in Mixing Capability

The integrated mixer features the same ultra low-noise, high-headroom mic preamps that have made BEHRINGER mixers legendary, and the two inputs accept virtually any mic/line level signal you're likely to run across. Variable Input gain controls (with Clip LED) will have you dialing in the perfect level every time. And if you need more coverage, use the convenient Link Output XLR connector to add more active loudspeakers.

## Power and Control

There is absolutely no substitute for amplifier power in high-performance loudspeakers; the kind of power it takes to deliver clean, in-your-face vocals and chest-thumping bass day in and day out. That's why we gave these bad boys 1000-Watts of bi-amplified, digitally processed output power. But with great

*Continued on next page*

## Rear Panel

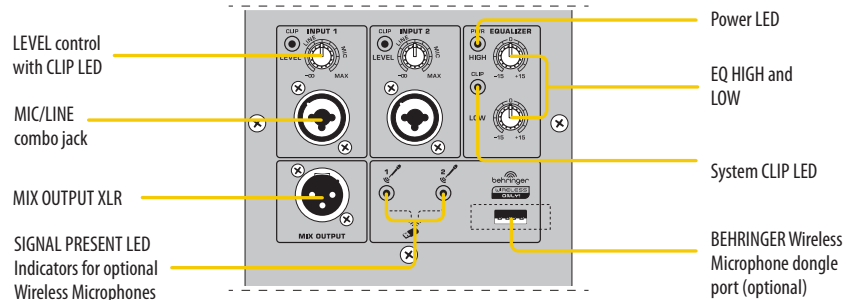

## Front View

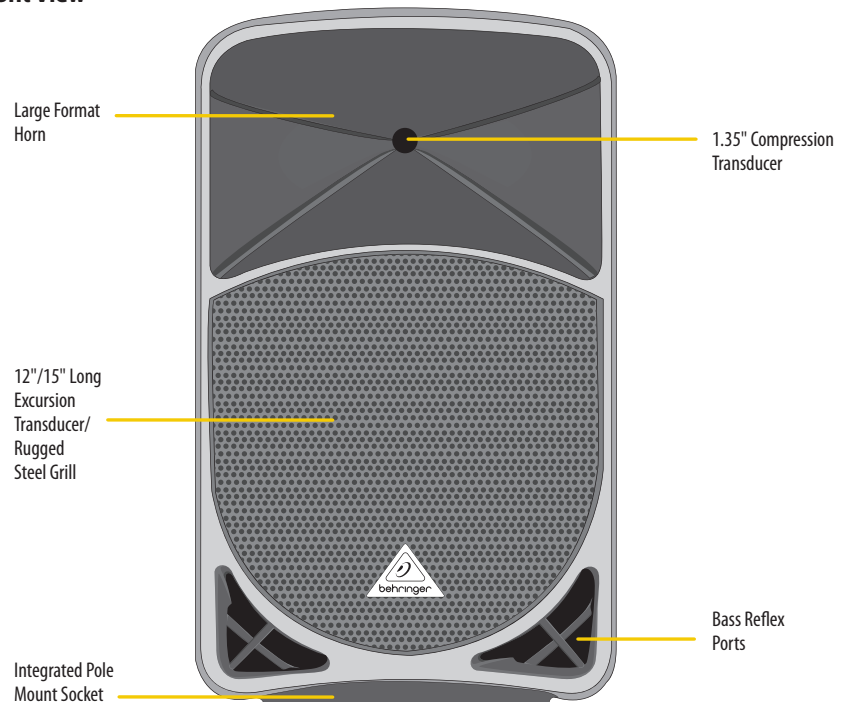

# EUROLIVE B115D/B112D

power comes great responsibility, so our engineers included a proprietary DSP (Digital Signal Processor) with high-end features such as a dual-band EQ, an active crossover, dual protection limiters and transducer response correction, ensuring these loudspeakers deliver incredible output at the lowest possible distortion levels.

### Custom-Engineered Transducers

Powerful, high-efficiency Class-D amplifiers and Switch Mode Power Supply technology coupled with state-of-the-art DSP functionality sure sounds impressive—but what about the part of the system you actually hear? We never cut corners on our transducers (woofers and tweeters), and we never just pull what we have off the shelf. Our LF (Low Frequency) and HF (High Frequency) transducers are designed specifically for each application—it's what sets us apart from the competition. When you buy a BEHRINGER active loudspeaker, you can rest assured that the transducers inside have been engineered to perform flawlessly in conjunction with every other element for truly professional results. B115D and B112D active speaker systems crank out massive quantities of low end, with articulate, detailed mids and crystal-clear highs.

### Extraordinarily Versatile

Thanks to its trapezoidal shape, the B115D and B112D are suitable for a wide variety of applications. They can be mounted on standard speaker poles, placed vertically atop subwoofers, or even laid on their side for use as onstage monitor wedges. Their extraordinary fidelity and frequency response make them a favorite of vocalists and instrumentalists alike. Hook up is simple, requiring only a single XLR or 1/4" cable from your mixing console and power. Additional monitors can be chained together via the XLR Link Output jack on the rear panel.

### Which Speaker Should I Buy?

Well, let's start with your application... are you giving a speech in a hotel ballroom—or rocking out at the local bar or dance club? Whether to choose one speaker cabinet over another depends on your bass requirements. A 15" woofer has about 40% more surface area with which to move air than a 12" and that translates into more bass. So if you're addressing a small meeting, or jamming at the coffee house, the B112D might be all you'll ever need. But if you're providing disco in a busy nightclub, hosting Karaoke night in your living room, or just need to crank it up louder, then the B115D may be a better choice.

### Sound Value

EUROLIVE active PA loudspeakers stand head and shoulders above the rest of the pack and deliver exceptional performance, even when pushed to their limits. Lightweight and powerful, with built-in mixers, custom-designed transducers, and integrated wireless functionality, B115D and B112D active loudspeakers are ideal for both speech and music applications—at a price that is unheard of in this class.

Experience the B115D and B112D at your local dealer today and find out why more and more professionals are turning to BEHRINGER EUROLIVE Series active loudspeakers for their superb performance and extraordinary value.

## Connecting a Microphone

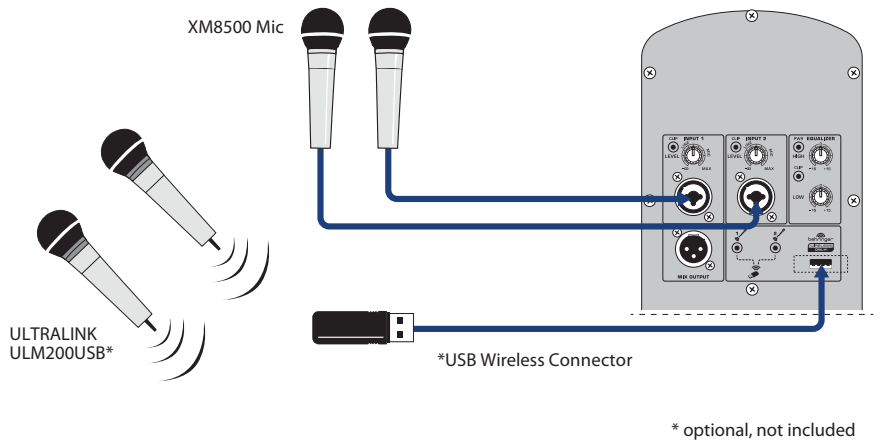

## Connecting Multiple Loudspeakers

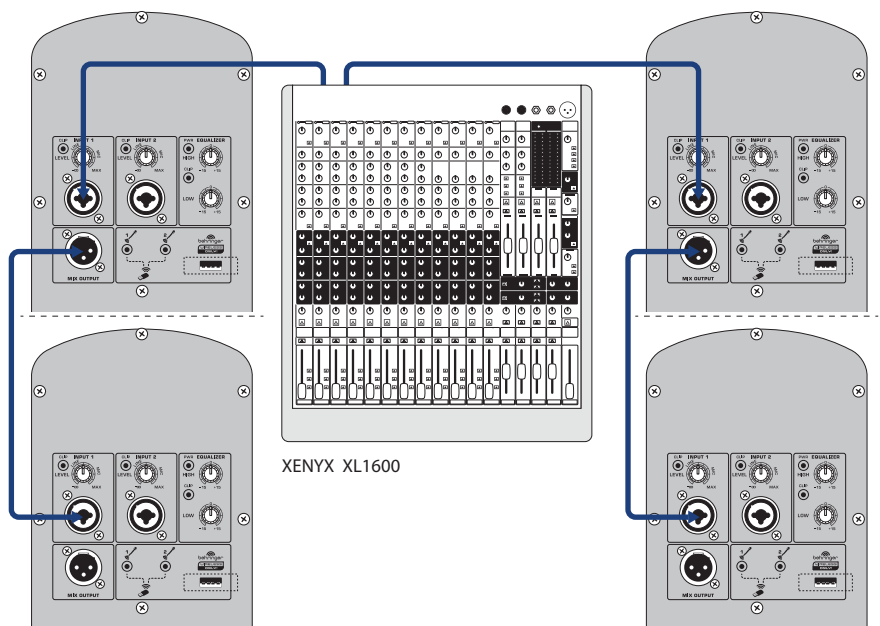

# EUROLIVE B115D/B112D

## Specifications

### B115D/B112D

#### Amplifiers

##### Low-Frequency Range

Max output power 700 W\*

##### High-frequency range

Max output power 300 W\*

#### Audio Inputs

##### XLR (Servo-Balanced)

Sensitivity -36 dBu to 0 dBu

Input impedance 14 kΩ

##### ¼" TRS Jack (Servo-Balanced)

Sensitivity -36 dBu to 0 dBu

Input impedance 14 kΩ

#### Wireless System

Connector USB 3.0

Frequency band 2.4 GHz

Frequency response (Wireless Link) 20 Hz - 20 kHz (+0/-2.5 dB)

Range Max. 80 m (line of sight)

#### Audio Outputs

##### Mix

Connector XLR, balanced

#### Level Control

Input trim -∞ to +36 dB

Max. input level 18 dBu

### B115D

#### Loudspeaker System Data

Frequency response 45 Hz to 20 kHz

Crossover frequency 2.2 kHz

Limiter Optical

Dynamic equalizer Processor-controlled

### B112D

#### Loudspeaker System Data

Frequency response 50 Hz to 20 kHz

Crossover frequency 2.8 kHz

Limiter Optical

Dynamic equalizer Processor-controlled

### B115D/B112D

#### Equalizer

High +/-15 dB @ 12 kHz

Low +/-15 dB @ 80 Hz

#### Power Supply

##### Voltage (Fuses)

USA / Canada 120 V, 60 Hz (T 6.3 A H 250 V)

UK / Australia 240 V~, 50 Hz (T 3.15 A H 250 V)

Europe 230 V~, 50 Hz (T 3.15 A H 250 V)

Japan 100 V~, 50-60 Hz (T 6.3 A H 250 V)

Power consumption max. 110 W

Mains connection Standard IEC receptacle

### B115D

#### Dimensions/Weight

Dimensions (H x W x D) 28.1 x 16.8 x 12.3"  
713 x 427 x 313 mm

Weight 38.9 lbs / 17.7 kg

### B112D

#### Dimensions/Weight

Dimensions (H x W x D) 22.4 x 13.4 x 10.6"  
568 x 342 x 270 mm

Weight 27.1 lbs / 12.3 kg

\*Independent of limiters and driver protection circuits

Please note these specifications are preliminary and conceptual in nature, and as such are subject to change as product development progresses. This information is supplied for market research purposes only and is not to be made public in any manner. This document is solely the property of The MUSIC Group, or one of its subsidiaries, and must be surrendered upon request of the owner.

For service, support or more information contact the BEHRINGER location nearest you:

**Europe**  
MUSIC Group Services UK  
Tel: +44 156 273 2290  
Email: CARE@music-group.com

**USA/Canada**  
MUSIC Group Services NV Inc.  
Tel: +1 702 800 8290  
Email: CARE@music-group.com

**Japan**  
MUSIC Group Services JP K.K.  
Tel.: +81 3 6231 0454  
Email: CARE@music-group.com

Technical specifications and appearances are subject to change without notice and accuracy is not guaranteed. BEHRINGER, KLARK TEKNIK, MIDAS, BUGERA, and TURBOSOUND are part of the MUSIC Group (music-group.com). All trademarks are the property of their respective owners. MUSIC Group accepts no liability for any loss which may be suffered by any person who relies either wholly or in part upon any description, photograph or statement contained herein. Colors and specifications may vary from actual product. MUSIC Group products are sold through authorized fulfillers and resellers only. Fulfillers and resellers are not agents of MUSIC Group and have absolutely no authority to bind MUSIC Group by any express or implied undertaking or representation. This manual is copyrighted. No part of this manual may be reproduced or transmitted in any form or by any means, electronic or mechanical, including photocopying and recording of any kind, for any purpose, without the express written permission of MUSIC Group IP Ltd. ALL RIGHTS RESERVED. © 2013 MUSIC Group IP Ltd. Trident Chambers, Wickhams Cay, P.O. Box 146, Road Town, Tortola, British Virgin Islands.