



# Audio Press Box<sup>®</sup>

## APB-320 USB-C

Press Conference Audio Distribution Amplifier  
Owner's manual

English



**Always follow the basic precautions listed below to avoid the possibility of serious injury or even death from electrical shock, short-circuiting, damages, fire or other hazards. These precautions include, but are not limited to, the following:**

## **WARNING**

---

### **Power supply/Power cord**

- Only use the voltage specified as correct for the device. The required voltage is printed on the name plate of the device.
- Use only the specified AC power adaptor.
- Do not place the power cord near heat sources such as heaters or radiators, and do not excessively bend or otherwise damage the cord, place heavy objects on it, or place it in a position where anyone could walk on, trip over, or roll anything over it.

### **Do not open**

- Do not open the device or attempt to disassemble the internal parts or modify them in any way. The device contains no user-serviceable parts. If it should appear to be malfunctioning, discontinue use immediately and have it inspected by qualified AudioPressBox service personnel.

### **Water warning**

- Do not expose the device to rain, use it near water or in damp or wet conditions, or place containers on it containing liquids which might spill into any openings.
- Never insert or remove an electric plug with wet hands.

### **If you notice any abnormality**

- If the power cord or plug becomes frayed or damaged, or if there is a sudden loss of sound during use of the device, or if any unusual smells or smoke should appear to be caused by it, immediately turn off the power switch, disconnect the electric plug from the outlet, and have the device inspected by qualified AudioPressBox service personnel.
- If this device or the AC power adaptor should be dropped or damaged, immediately turn off the power switch, disconnect the electric plug from the outlet, and have the device inspected by qualified AudioPressBox service personnel.



**Always follow the basic precautions listed below to avoid the possibility of physical injury to you or others, or damage to the device or other property. These precautions include, but are not limited to, the following:**

## **CAUTION**

---

### **Power supply/Power cord**

- Remove the electric plug from the outlet when the device is not to be used for extended periods of time, or during electrical storms.
- When removing the electric plug from the device or an outlet, always hold the plug itself and not the cord. Pulling by the cord can damage it.
- To avoid generating unwanted noise, make sure there is 50cm or more between the AC power adaptor and the device.
- Do not cover or wrap the AC power adaptor with a cloth or blanket.

### **Location**

- Before moving the device, remove all connected cables.
- When setting up the device, make sure that the AC outlet you are using is easily accessible. If some trouble or malfunction occurs, immediately turn off the power switch and disconnect the plug from the outlet.
- Avoid setting all controls to their maximum. Depending on the condition of the connected devices, doing so may cause feedback and may damage the speakers.

- Do not expose the device to excessive dust or vibrations, or extreme cold or heat (such as in direct sunlight, near a heater, or in a car during the day) to prevent the possibility of panel disfiguration or damage to the internal components.
- Do not place the device in an unstable position where it might accidentally fall over.

#### **Connections**

- Before connecting the device to other devices, turn off the power for all devices. Before turning the power on or off for all devices, set all volume levels to minimum.

#### **Handling caution**

- When turning on the AC power in your audio system, always turn on the power amplifier LAST, to avoid speaker damage. When turning the power off, the power amplifier should be turned off FIRST for the same reason.

- Do not insert your fingers or hands in any gaps or openings on the device.
- Avoid inserting or dropping foreign objects (paper, plastic, metal, etc.) into any gaps or openings on the device. If this happens, turn off the power immediately and unplug the power cord from the AC outlet. Then have the device inspected by qualified AudioPressBox service personnel.
- Do not use the device or headphones for a long period of time at a high or uncomfortable volume level, since this can cause permanent hearing loss. If you experience any hearing loss or ringing in the ears, consult a physician.
- Do not rest your weight on the device or place heavy objects on it, and avoid use excessive force on the buttons, switches or connectors.

XLR-type connectors are wired as follows (IEC60268 standard): pin 1: ground, pin 2: hot (+), and pin 3: cold (-).

AudioPressBox cannot be held responsible for damage caused by improper use or modifications to the device, or data that is lost or destroyed.

Always turn the power off when the device is not in use.

The performance of components with moving contacts, such as switches, volume controls, and connectors, deteriorates over time. Consult qualified AudioPressBox service personnel about replacing defective components.

Illustrations herein are for explanatory purposes only, and may not match actual appearance during operation.

Company names and product names herein are trademarks or registered trademarks of their respective companies.

Specifications and descriptions in this owner's manual are for information purposes only. AudioPressBox reserves the right to change or modify products or specifications at any time without prior notice. Since specifications, equipment or options may not be the same in every locale, please check with your AudioPressBox dealer.



**Use only the adaptor included with this AudioPressBox. Use of a different adaptor may result in equipment damage, overheating, or fire.**

**Be sure to unplug the adaptor from the outlet when not using AudioPressBox, or when there are lightning storms in the area.**

**To avoid generating unwanted noise, make sure there is 50 cm or more between the power adaptor and AudioPressBox.**



## APB-320 USB-C

Dear customer,

Thank you for purchasing the AudioPressBox® **APB-320 USB-C**.

**APB-320 USB-C** is a professional portable active press box (Audio Splitter) suitable for both indoor and outdoor press conferences. It features 2 Analog Mic/Line Inputs, 1 Digital USB-C In & Out, 16 Analog Mic/Line Outputs and 4 Digital USB-C Outputs. Each Analog Output is independent transformer balanced and isolated. The **APB-320 USB-C** also includes a rechargeable Battery-pack so it can run on its own up to 20 hours. All of this is placed in a waterproof, heavy duty Nanuk case.

### Features:



#### Phantom power

It provides 48V phantom power for condenser microphones.



#### Transformer

Individually transformer isolated and balanced outputs.



#### Mic/Line switch

26dB input PAD. Selection of the input sensitivity – for devices with microphone or line level outputs.



#### Rechargeable batteries

Built-in Li-Ion battery pack with battery management, 20 hour working time at full load. 2,5h charging time.



#### USB Type C

Digital audio interface for use with video-conference and for live streaming or digital recording.

### The package contains

1. AudioPressBox unit.
2. Power supply
3. Manual
4. Test report

# APB-320 USB-C

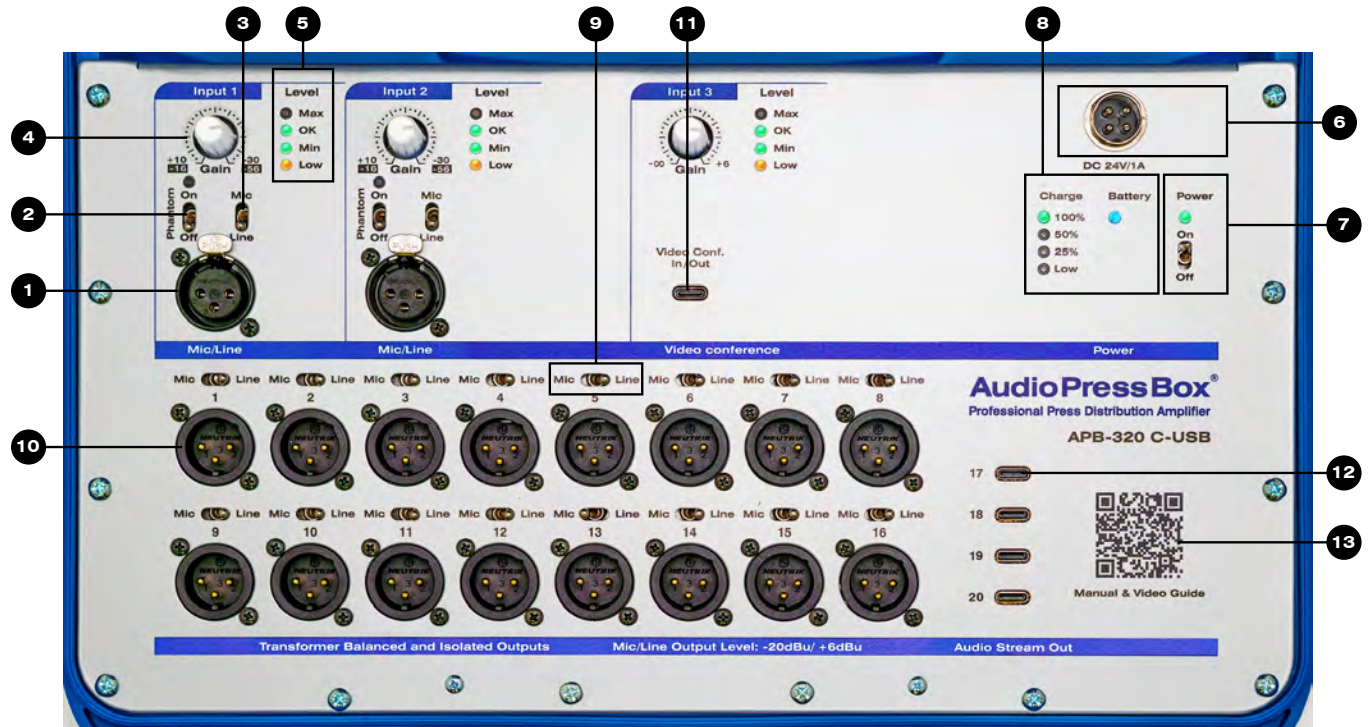

## 1) XLR Input connector

Plug your microphone or line-level source into this XLR balanced connector. You can connect any type of condenser or dynamic microphone here or also output from a mixing console.

(Pinout: 1-Ground, 2-Hot, 3-Cold).

## 2) Phantom power switch with indicator

If you are about to use a condenser microphone, turn the Phantom power switch ON to feed your microphone with 48V. If you use dynamic microphone or microphone with his own power, you can switch this OFF.

## 3) Mic/Line Input switch

26dB PAD – input sensitivity selector. If you are using microphone as an input, this lever should be set to “Mic” position. If you are using Line input e.g. output from the mixing console, please set this switch to “Line” position. In the Line position the Phantom power is automatically turned OFF.

## 4) Input Gain knob

You can set the input signal gain depending on the connected audio source to reach the optimal output level. You can check the signal level on the Level indicator (5).

## 5) Input Level indicator

Displays the input signal level. To achieve nominal output level, set the Input gain (4) so that the LED “OK” will be at least blinking.

## 6) Power supply connector

Plug the Power adaptor cable here. Please use only power adaptor supplied with AudioPressBox unit.

## 7) Power switch

With the power switch, you can turn your AudioPressBox® ON or OFF. When AudioPressBox® is turned on, Power indicator lights green.

## 8) Battery and Charge Level indicator

When APB is turned ON and is running on battery, the Battery indicator lights blue. Then the Charge indicator indicates the actual battery charge level in percent. When APB is turned ON and plugged to the mains, the battery is being charged and the Battery indicator is off. In this case the Charge indicator indicates a charging process.

## 9) Mic/Line Output Switch

Output PAD. Each output is switchable between Mic and Line output level. Nominal Mic level: -20dBu / Nominal Line level: +6dBu

### 10) XLR Output connector

Each output is balanced and individually transformer isolated. It is a balanced XLR connector.

(Pinout: 1-not connected, 2-Hot, 3-Cold)

### 11) USB-C In & Out connector

USB Type-C connector for Digital audio interface input and output. This In & Out is for video-conference connection. (both Analog inputs are transmitted to video-conference and the video-conference output is mixed with Analog inputs and sent to all APB Outputs)

### 12) USB-C Output connector

USB Type-C Digital audio interface output for live streaming or digital recording. You can connect your Laptop or Smartphone (with Digital Audio Interface support) here.

### 13) QR – Code

Scan this QR code for access to our product support page with user manual, video guide and user guide.



# Usage

**APB-320 C-USB** is designed for use as a distribution audio amplifier for press conferences. It features two analog inputs with input PAD – Mic/ Line switch, one digital input and output USB interface, sixteen analog audio outputs with individual output level switch – Mic/Line and four digital USB audio outputs. Analog inputs also feature built-in fixed High Pass Filter set to 120Hz and fixed Compressor with Limiter to ensure high quality output signal without pops especially when used with microphones. Mic/Line Switch is input PAD (-26dB) for selecting the input sensitivity for microphone or line level inputs. With switch set to Mic you can connect input signal levels from -56dBu to -16dBu and at Line position from -30dBu to +10dBu. When Mic input level sensitivity is set you can also turn ON the Phantom power for the microphone – please use this with condenser microphones only. When the input sensitivity is set to Line, the Phantom power is automatically turned OFF to avoid damage of connected device.

Digital USB Video-Conf. In/ Out is for connection to video-conference where signals from both analog inputs are mixed and transmitted to connected device and the audio from the video-conference (other side) is mixed with analog inputs and sent to all outputs (analog and also USB). So, the video-conference attendants can hear speakers connected to AudioPressBox and journalists can record speakers from the room and also speakers attending the videoconference.

USB outputs carries the same audio signal as analog XLR outputs. These outputs can be used for live streaming on social media or for digital recording on laptop or smartphone which supports digital USB audio interface.

For proper operation and to maintain declared parameters, it is necessary to drive the APB with the correct signal level from Analog or USB Inputs. For checking the input signal level there is an Input Signal Indicator for each Input. You have proper input signal if the LED “OK” is at least blinking. You can adjust the right input level for Analog and USB Inputs with dedicated Gain knob

Each analog XLR output is individually transformer balanced and isolated. You can switch the output level for each output separately to Mic or Line level.

Thanks to the built-in 14,8V 2200mAh Li-Ion battery-pack you can use your press box also on places where is no electric power available. So, no matter if your conference is indoors or outdoors. Our APB can operate up to 20 hours from the battery-pack on full load. Thanks to the Charge status indicator you always know what is the actual battery-pack charge. If powered from battery-pack and the LED “LOW” is blinking you should immediately find the power source or the APB will be soon out of power and will Turn OFF. Charge time for fully discharge battery-pack is around 2,5 hours. Every time the power adaptor is connected, the battery-pack is charging. No matter if the Power Switch is turned ON or OFF. There is also battery management built in for the battery-pack, so it can't be overcharged or deeply discharged. **Please never left the unit in discharged state for a longer period of time – it can damage the battery. It is recommended to charge it before not using it for a longer period.**

# Operation

## **Analog Input:**

1. Connect your input device with the XLR cable to the input connector of the APB.
2. Set the Mic/Line switch to desired position – if you use Mic Level input device like a microphone set it to “Mic”, if you use a line level input device like a mixing console set it to “Line” position.
3. When you are using a condenser microphone, turn the Phantom switch to the “ON” position, in other cases leave it in “OFF” position.
4. Connect the power adaptor to the Power connector. (If the mains power is available)
5. Turn the APB ON with the Power switch.
6. Adjust the input level with the Gain knob that the LED “OK” is at least blinking.
7. Set your output level – Mic or Line and connect your device – e.g. camera or recorder.
8. You are ready now!

## **USB Video-Conf. In/ Out:**

1. Connect the power adaptor to the Power connector. (If the mains power is available)
2. Turn the APB ON with the Power switch.
3. Connect your laptop with APB via USB-C cable.
4. On your video-conference client choose the USB audio codec as the microphone and speaker
5. Set up the levels – Set the USB input gain on APB that the LED “OK” is at least blinking on the level meter.
6. Set the desired output level switch for each output as desired – Mic or Line.
7. APB is ready to use!



# Specifications

Audio Press Box APB-320 USB-C						
Type	3 in 20 out					
Groups	1					
<b>Input section</b>						
<b>Analog:</b>	<b>Inputs</b>	2 analog, 1 digital	<b>Input connectors</b>	Balanced, XLR	<b>Phantom Voltage</b>	48V
	<b>Input Gain</b>	Mic: +22/+62 dB		Line: -4/+36 dB		
	<b>Max. input level</b>	Mic: -10/-30dBu		Line: +36/-4dBu		
	<b>Input Impedance</b>	Mic: 2,4 kOhm		Line: 3,5 kOhm		
<b>Digital:</b>	<b>Input connector</b>	USB Type C				
	<b>Compliant USB Specification</b>	USB 2.0	<b>Supported Sampling Rates</b>	32kHz, 44.1kHz, 48kHz	<b>Interface Powering</b>	Bus Powered*
	<b>Input Gain</b>	-∞/+6 dB	<b>Bit Depth</b>	16-Bit	<b>Charging capability</b>	No
<b>Output section</b>						
<b>Outputs</b>	16 Analog with Line/ MIC level, 4 Digital					
<b>Output connectors</b>	Balanced, XLR					
<b>Nominal Output Level</b>	+6dBu					
<b>Maximum Output Level</b>	+20dBu (no load) +14dBu (600Ohm)					
<b>Output impedance</b>	Mic: 220 Ohm	Line: 600 Ohm	<b>Output connector</b>	USB Type C	<b>Interface Powering</b>	Bus Powered*
<b>Transformer isolated outputs</b>	Yes ( <b>each output</b> )		<b>Compliant USB Specification</b>	USB 2.0	<b>Charging capability</b>	No
<b>SNR</b>	86dB		<b>Supported Sampling Rates</b>	8kHz, 11.025kHz, 16kHz, 22.05kHz, 32kHz, 44.1kHz, 48kHz		
<b>Frequency Response</b>	120Hz to 30kHz/ -3dB		<b>Bit Depth</b>	16-Bit		
<b>Controls</b>	<b>Input section:</b> 26dB PAD, Input gain, Phantom				<b>Output section:</b> Power switch, Output PAD	
<b>Indicators</b>	<b>Input section:</b> Phantom power, Input level					
<b>Power Supply</b>	24V DC, 1A external adaptor					
<b>Battery</b>	Li-Ion, 14,4 V 2200mAh					
<b>Battery operation time</b>	up to 20hrs					
<b>Dimensions (WxHxD)</b>	370x120x300 mm					
<b>Weight</b>	5,2 kg					

# Block diagram

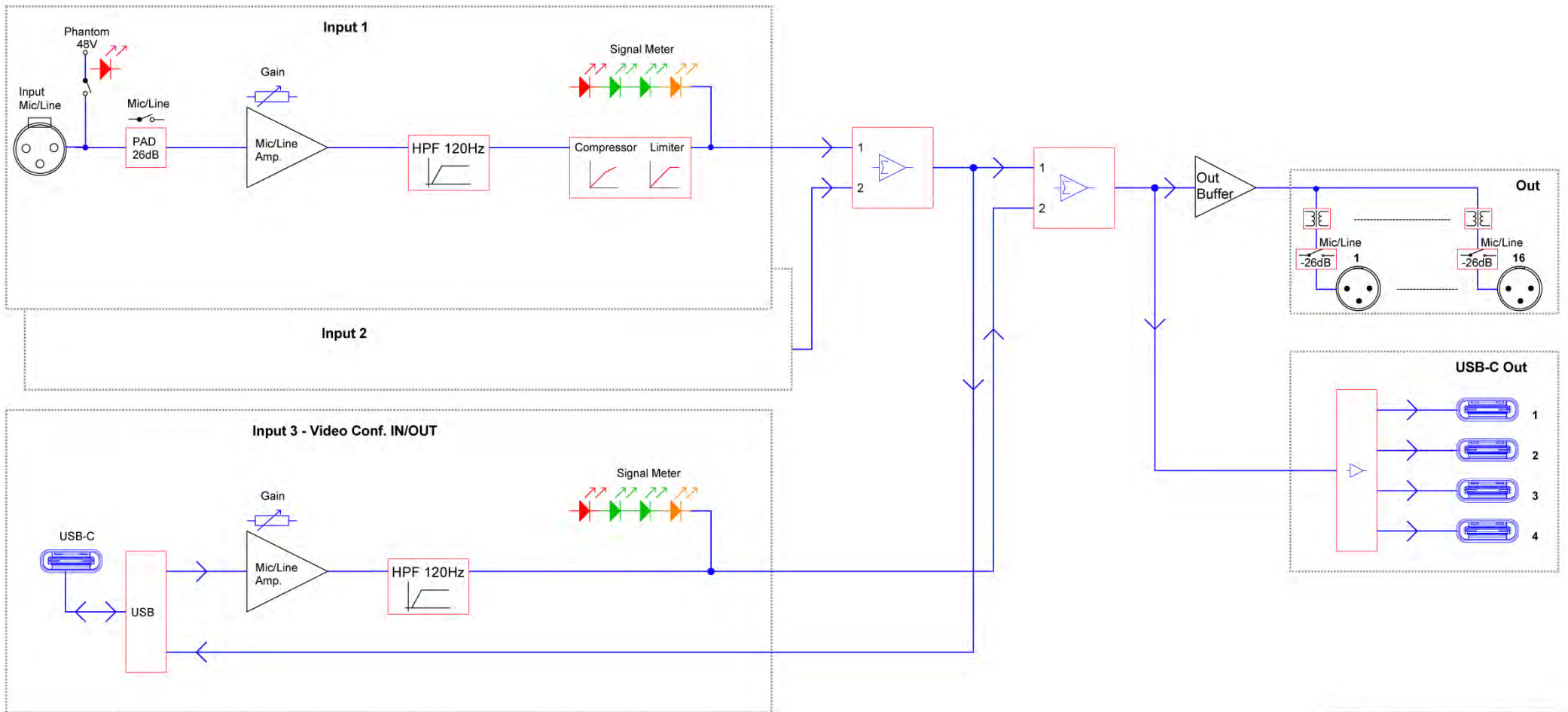

**AudioPressBox®**  
**APB-320 C-USB**

# Audio Press Box<sup>®</sup>

e-mail: [sales@audiopressbox.com](mailto:sales@audiopressbox.com) | web: [www.audiopressbox.com](http://www.audiopressbox.com)

MediaTech Central Europe, a.s., Drienova 34, 821 02 Bratislava, Slovak Republic (EU)  
Tel: +421 2 20 999 700