

# **FWT-8848 GSM (GATEWAY)**

## **USER'S MANUAL**



**COPYRIGHT -2009 1'ST VERSION**

## 1,General Description:

FWT-8848 is a GSM to Analog Converter(single port,insert 1 sim card only), the device can produce a FXS line to allow a regular phone to be connected and used just like a local landline(PSTN) except your calls will go out the GSM network. This device can both receive and make calls.

The main application is: Connecting the RJ-11 FXS line to connect Ordinary telephone set for voice call, to connect PBX for call extentions, to connect billing systems for public phone use, to connect VoIP gateway to realize VoIP call termination, to connect alarm system for security purpose, etc. It is not a VOIP gateway, nor a GSM+VOIP gateway, It is a GSM Fixed Wireless Terminal that produces a Analog FXS phone line.

### Available:

- I GSM 900/1800Mhz dual band, employing Wavecom Q2303A, Q2403A Sim300W module to make;
- I GSM 900/1800/1900Mhz Tri-band, employing Sim300z module to make;
- I GSM850/900/1800/1900Mhz Quadband, employing Sim340z module to make.

1, Front Picture



2, Rear Picture



3, Front Picture with Antenna connection



4, Bottom side picture



1), **Front side** has LEDs display for Signal strength, Power, Working Status and Talking indicator;

- 2), **Rear side** has 1 pcs SMA antenna connectors, 2 RJ-11 output, Power port and switch;
- 3), **Front side with 3m cable antennas**, this only for display picture, in installation, antenna must be put beyond 1.5m from terminal. Can't be mounted on the terminal, otherwise noise will be made;
- 4), **Bottom side** has 1 pcs Sim card holder slots, you can insert Sim card into the slot .

## 2,Features:

- 1) It is a 1 channel GSM Gateway which has 2 RJ-11 outputs for extensions;
  - 2) It can connect with ordinary telephone set, PBX , VOIP Gateway, Billing meter etc. ;
  - 3) Dialing tone frequency:450hz;
  - 4) Employ Industrial module [Sim300( Tri-band 900/1800/1900Mhz),Sim340 (Quadband 850/900/1800/1900Mhz) or Wavcom Q2303A,Q2403A,SIM300W(Dual band 900/1800Mhz)] to make;
  - 5) Can adjust dial interval from 0.5sec to 9 secs by setting up from telephone set;
  - 6) Can adjust voice volume by setting up from telephone set;
  - 7) SIM card supported (1.8V, 3V);
  - 8) Caller ID display;
  - 9) DTMF Dialing;
  - 10) Bell signal;
  - 11) Polarity reversal;
  - 12) The RJ-11 socket which connect the phone or billing system for metering purpose;
  - 13) Antenna socket (SMA);
  - 14) IP Presetting;
  - 15) Working status and Signal Strength by LED indicator;
  - 16) IMEI Change (optional).
- 17) back up Li-ion battery( Optional) 7.2V 1300mAh.standby 24hrs,talking time: 2.5hrs.

## 3,Technical Specifications

Air interface standard: GSM850/1900Mhz,900/1,800Mhz phase 2+ full band

Frequency ranges:

- |                                   |                                     |
|-----------------------------------|-------------------------------------|
| A) GSM 850                        | GSM 1900:                           |
| I) Transmission: 869.2 ~ 893.8MHz | I) Transmission: 1, 930 ~ 1, 990MHz |
| II) Reception: 824.2 ~ 848.2MHz   | II) Reception: 1, 850 ~ 1, 910MHz   |
| B) GSM 900:                       | GSM 1800:                           |
| I) Transmission: 890 ~ 915MHz     | I) Transmission: 1, 710 ~ 1, 785MHz |
| II) Reception: 935 ~ 960MHz       | II) Reception: 1, 805 ~ 1, 880MHz   |

Phone interface: supply RJ-11 Phone Interface

Hanging voltage: 45V

Picking off voltage: 30mA / 41mA

Dialing tone Frequency: 450Hz

Antenna interface: Antenna amplifying>2.5db

Sensitivity:<-104DBM

Transmitting power<3W

AC-Adapter interface: Input: AC 110~240VAC 50~60Hz  
Output: 12DC 1A.

AC-Adapter type: EU,US,AU,British can be optional

#### **4,Operation Circumstance:**

Operation temperature: -10c~60C

Storage temperature:-20C~70C

Operation humidity:45%-95%

Atmosphere pressure:86-106Kpa

Environment noise: <60DB

Transmitting Power:2W

Sensitivity: <-104dbm

Antenna Amplifying: >2.5db

Dialing frequency: 450Hz

Hanging voltage: 45V

Picking current: 30mA/41mA

#### **5,Check Package:**

FWT-8848 GSM FWT **1 piece**;

Ac-adapter 12V 1A: **1 piece**,

GSM Antenna with 3m cable **1 piece**,

User's Manual **1 piece**,

G.W: **0.75kg** per unit. And **20pcs per carton, 16kg per carton.**

Gift carton Measurement: **55cmX34.5cmX32.5cm**

#### **6,Installation And Connection**

##### **The Condition for Installation**

The terminal asks for 110- 220V AV power supply. It must be installed in the area where the GSM network can cover. The strength of the signal can affect the quality of voice.

1. Screw off the screws that are on the back of the terminal, Insert SIM card for every Sim card holder, and then tighten the screws.
2. Install antenna. In order to ensure the quality of voice, antenna must be put beyond 1.5 from the telephone and terminal.
3. On end of the telephone line connects to the "Phone" port of the terminal, the other end connects to telephone.
4. "Power" port connects to power adapter that is connected to 110-220V AC power supply.

##### **1) The Installation for Connecting to Ordinary Telephone**

The Sketch for connecting ordinary Telephone

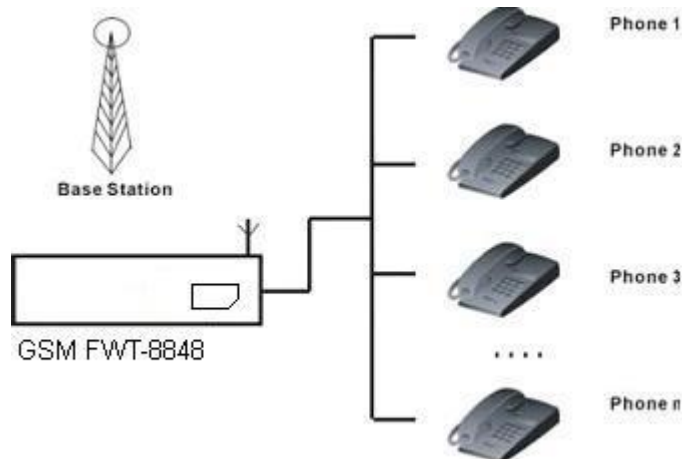

**Draw your attention:** Because there are many types of ordinary telephone and their electric parameters are different. In order to avoid mutual disturbance between telephone and terminal and affect voice quality. The distance between telephone and terminal is 1.5m at least.

### 2) The installation for connecting to billing device for metering

If the users demand to register cost during calls, billing device can be connected between terminal and ordinary telephone. Billing device register cost according to the anti-polarity signal that is provided by terminal.

The sketch for connecting to Billing device or Computer charging system

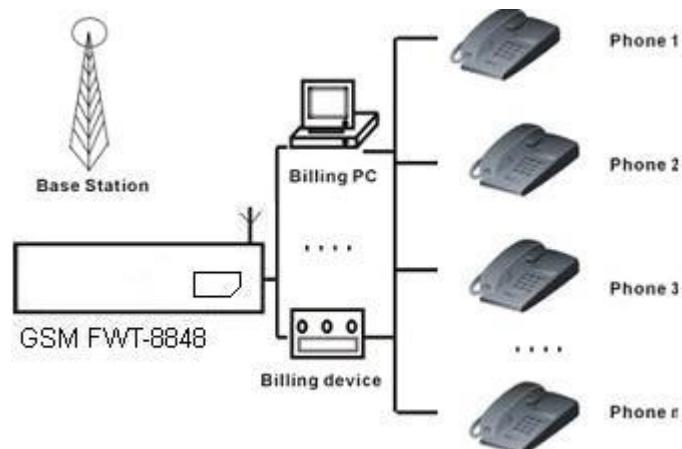

### 3) The installation for connecting to PBX for call extentions

If users want to connect small PBX to this terminal, connect terminal's "Phone port" to the PBX.

The sketch for connecting to PBX device.

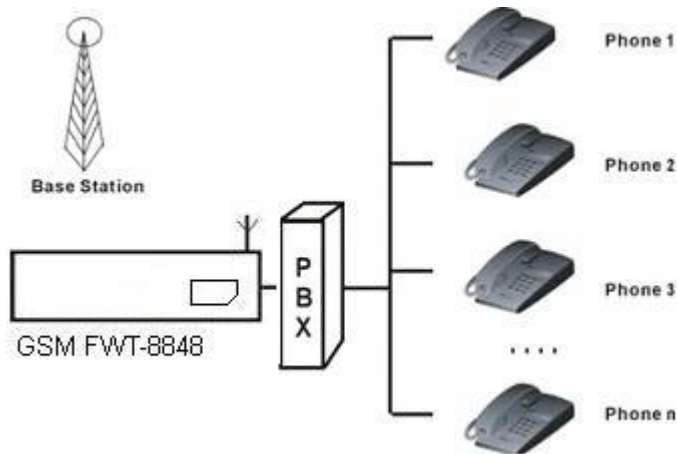

**4) The installation for connecting VoIP gateway for Call Termination**

Suppose a VoIP call originates from US, which was transferred from US Server to China Server on VoIP, finally the call will be terminated from internet to GSM network and to be sent out to the destination answer side.

The sketch for connecting to VoIP gateway

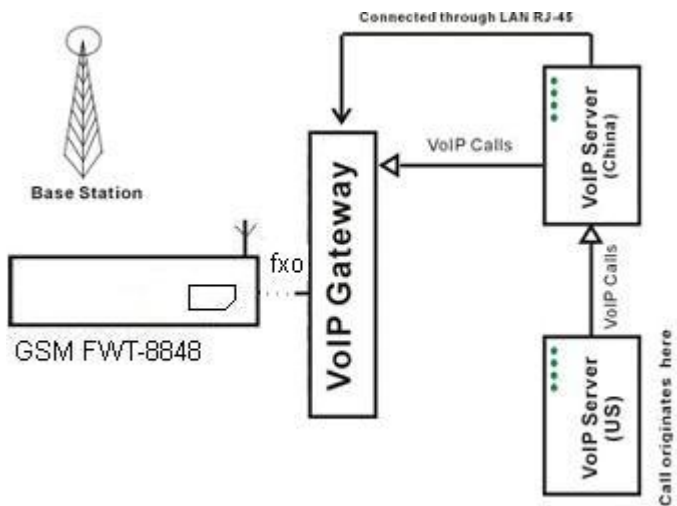

**5) The installation for connecting to alarm system for Security**

The GSM FWT can substitute the PSTN for connecting to alarm system for security purpose when PSTN failure or not available.

The sketch for connecting to alarm system

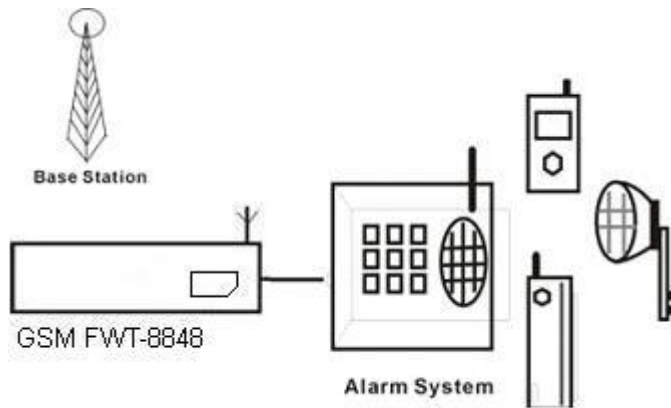

## 7, Function Setting

Before you do the following function settings, Lift handset or press hands free key of telephone set, then you can press the buttons according to the following instructions to finish setting, you will hear 2 beeps after you finish, this testify setting successfully.

### 1) Adjust dial interval

\*#01#30# , 01--command, 30--time, Max 9.9 seconds, Min 0.5 seconds, factory default setting is 3 seconds.

**\*If you use FWT-8888 for connecting to VoIP gateway, you can set dial interval as 0.5 second, it can make PDD<5 sec (Method: \*#01#05#);**

**\*If you use FWT-8888 for connecting telephone, PBX, billing device, you can set dial interval as 3 seconds or 5 seconds as you like (Method: \*#01#30#, set the dial interval as 3 seconds).**

### 2) Adjust Earphone Volume

\*#02#15# 02--command, 15--volume, Max 16, Min 1, factory default setting is 15.

### 3) Adjust Mic. Volume(sensitivity)

\*#03#10# 03--command, 10--amount, Max 16, Min 1, factory default setting is 10.

### 4) Setting local area code

\*#04#\*0755# 10--command, \*0755—area code, Max 5 numbers, use "\*" instead if area code is less than 5 digits.

### 5) Setting IP numbers

\*#05#17911# 05--command, 17911—IP numbers, Max 5 numbers, use "\*" instead if IP number is less than 5 digit.

### 6) Restore to factory default setting

\*#99#99# Restore to factory default setting.

### 7) IMEI change

We will provide you data cable and software for you, If you need to do IMEI change, Contact with

our sales staff for inquiry.

## **8, Making Calls and Answer Incoming Calls**

### **Making Calls**

1. Lift the handset or press “hand-free” key, you will hear dialing tone, then you can dial the telephone numbers you want to call.
2. Dialing: dialing the telephone numbers you want to call
3. On completion of dialed digits, you can press “#” to transmit the called telephone numbers. If you don’t dial any key for continual 3 seconds during the dialing, terminal transmits called telephone numbers automatically.
4. During calls, if the telephone numbers is not free ones, the terminal sends out anti-polarity signal.
5. If the calling party or called party hangs up, the terminal stops sending out anti-polarity signal.

### **Answering Incoming Calls**

When some calls are coming in, if the connected telephone has the function of displaying incoming calls, the telephone rings and displays the incoming telephone numbers. Now users can lift the handset or press “hand-free” to answer it.